



Architects

Solving Top 20 Accessibility Failures

Course Number: AIAPDH264
1 LU|HSW

PO Box 449 Pewaukee, WI 53072 (888) 564-9098

arch-support@edcet.com

Final Exam – Solving Top 20 Accessibility Failures

1. What is the required clear floor space for a sink or lavatory not located within an alcove?
 - a. 24" x 48"
 - b. 30" x 48"
 - c. 36" x 48"
 - d. 30" x 60"
2. What is the required clear floor space for a urinal located within a 25" deep alcove?
 - a. 24" x 48"
 - b. 30" x 48"
 - c. 36" x 48"
 - d. 30" x 60"
3. How much clearance is required above a grab bar?
 - a. None
 - b. 1-1/2"
 - c. 12"
 - d. 18"
4. In a wheelchair accessible restroom, the distance between the centerline of the toilet and side partition or wall may be which of the following?
 - a. 16"
 - b. 17"
 - c. 18"
 - d. All of the above
5. If you are approaching a door from the front on the pull side, how much maneuvering clearance is required perpendicular to the door?
 - a. 18"
 - b. 36"
 - c. 48"
 - d. 60"
6. When renovating a primary function area in a building, what must be accessible?
 - a. Only the space being renovating
 - b. The restrooms serving the renovated area
 - c. The employee lounge serving the employees who will be using the area being renovated
 - d. Both b and c.
7. What is the required width of an access aisle serving an 8' wide van accessible parking space?
 - a. 3'
 - b. 5'
 - c. 8'
 - d. 11'

8. How many accessible parking spaces are required at a shopping center lot that has a total of 350 parking spaces?
 - a. 6
 - b. 7
 - c. 8
 - d. 9
9. What is the maximum slope for flared sides of a curb ramp?
 - a. 1:20
 - b. 1:12
 - c. 1:10
 - d. 1:8
10. Which of the following is true regarding drinking fountains?
 - a. If drinking fountains are installed, they must be provided for both standing and wheelchair users.
 - b. If drinking fountains are installed, they only need to be installed at wheelchair-accessible heights.
 - c. If drinking fountains are being installed, one could be replaced with a bottle filler as long as the bottle filler is installed at an accessible mounting height.
 - d. If drinking fountains are being installed, the one designed for standing users could be replaced with a bottle filler.

Solving Top 20 Accessibility Failures

Introduction

The Americans with Disabilities Act (ADA) was signed into law in 1990, yet it is rare to find a newly constructed building that is 100 percent compliant with the *ADA Standards for Accessible Design*. There are common violations that are seen repeatedly. This course will identify twenty common errors, review the applicable *ADA Standards*, teach the correct way to design those individual elements and provide tips on how to detail construction documents to decrease the occurrence of the violations. This course is based on the *2010 ADA Standards for Accessible Design*, or *ADA Standards* for short. The *italic* numbers in parentheses are the referenced *ADA Standards* section numbers. Dimensions are for adult accessibility. Reference the *ADA Standards* for children's dimensions. All images are taken from the *U.S. Access Board Technical Guide* and the *ADA Standards* unless noted otherwise. A free downloadable version may be found at www.ada.gov. Remember that the Administrative Authority for local jurisdictions can modify the provisions and interpretations, so always check with the local governing authority for their specific requirements.

Sinks and Lavatories

Most common violations are observed in restrooms, as many public buildings have them. After you enter a restroom, one of the first things you usually see are the sinks. Countertops are oftentimes dimensioned on construction documents so that the tops are 34 inches above the finished floor. If a drop-in sink is also specified, this could be problematic. The *ADA Standards* state that the 34-inch maximum dimension should be measured to the *higher of* the sink rim or the counter surface. (606.3) Therefore, if a drop-in sink protrudes above the countertop, the 34-inch measurement should be to the top of the sink. There is an exception to this requirement. If the sink is in a single-user restroom that is accessed only from a private office, it does not have to comply.

While at the sinks, it is common also to observe exposed pipes. Both the water supply and drain pipes under the accessible sinks must be insulated or covered to protect someone from sharp or abrasive surfaces. (606.5) The water supply lines tend to be overlooked more often than the drain lines. If the plumbing is to be covered with panels instead of insulation, ensure that adequate knee and toe clearances are provided. Knee and toe clearance has to be at least 30 inches in width and 17 to 25 inches in depth from the leading edge of the clear floor space. Nothing can protrude into the required clearance other than the dip of the overflow. The 27-inch minimum high knee clearance can be reduced beyond a depth of 8 inches from the leading edge at a slope of 6:1 from 27 inches above the finish floor down to 9 inches above the finish floor. (306.3)

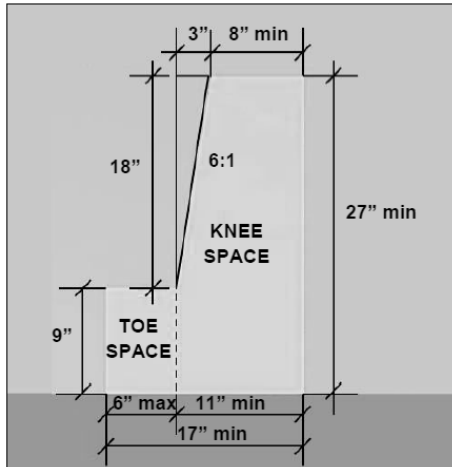

Knee and Toe Clearances

Toilet Accessory Mounting Heights

Care must be given when placing soap dispensers, paper towel dispensers, and hand dryers. The controls need to be within an accessible reach range. If the dispensers are located above a vanity or sink that is deeper than 20 inches, the maximum height of the controls is 44 inches above the finish floor if the dispenser is mounted on the rear wall. If the vanity or sink is less than 20 inches deep, the controls may be as high as 48 inches. It is preferable to place paper towel dispensers adjacent to accessible lavatories so a wheelchair user would not be forced to operate their device with wet hands.

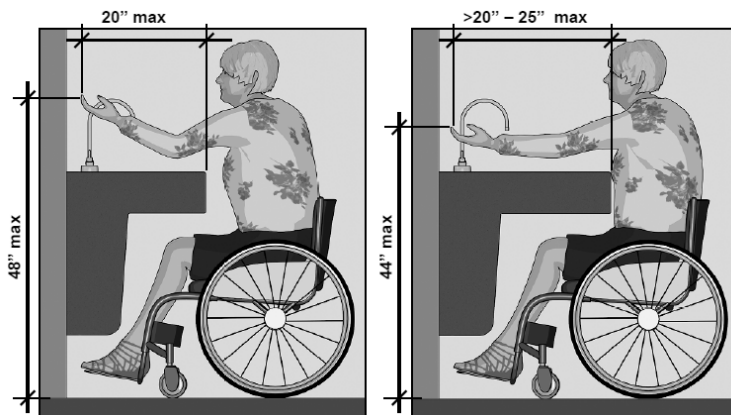

Reach at Lavatory

Oftentimes, dispensers are installed by owners. It is essential to educate the owners so that they will not be required to relocate them after the fact. Nobody wants to be left with unsightly holes or adhesive on the wall following a newly finished project.

Mirrors

Mirrors are often seen above lavatories in restrooms. The ADA Standards require that they be mounted so that the bottom edge *of the reflecting surface* is no more than 40 inches above the finish floor. (603.3) Oftentimes, drawings do not detail where to install mirrors. If a dimension is provided, it does not specify that it is to the bottom of the reflecting surface, so the bottom of the frame is mounted at 40 inches. When selecting mirrors, the width of the frames must be taken into consideration, as well as the heights of the countertop and backsplash, to ensure they are not mounted too high. Mirrors located elsewhere in the restroom must be installed with the lower edge of the reflecting surface at 35 inches above the finish floor.

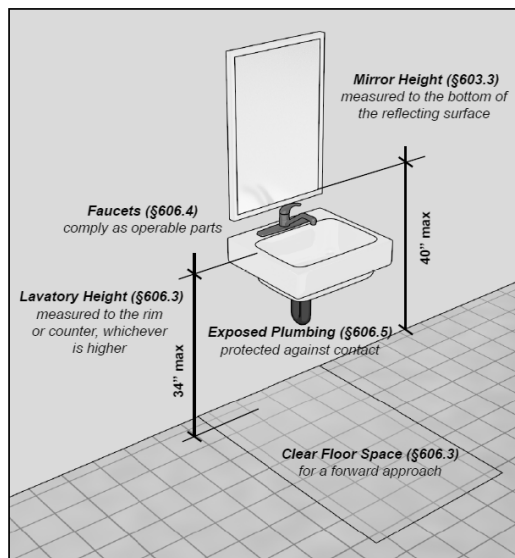

Lavatories

Urinals

Once you pass the sinks in a restroom, you may encounter the urinals, particularly in a men's restroom. If only one urinal is provided, it does not need to be accessible. (213.3.3) However, if more than one is provided, at least one must comply. A clear floor space positioned for a forward approach is required at the accessible urinal. (605.3) A standard clear floor space is 30 inches by 48 inches. The problem arises when urinals are placed between urinal screens that protrude from the wall more than 24 inches or when they are placed in an alcove that is deeper than 24 inches. At that time, the required clear floor space increases to 36 inches wide. Sometimes, the brackets used to mount the urinal screens to the wall cause the screens to protrude more than 24 inches. It is essential to review submittals before installing urinal screens.

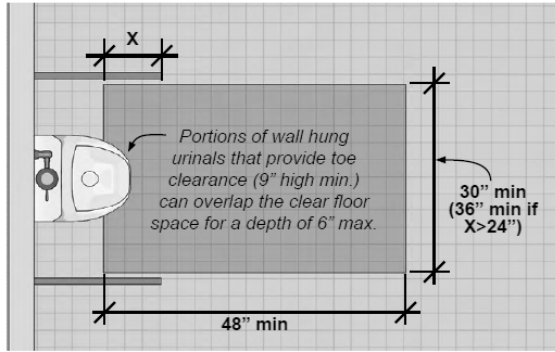

Urinals

Toilet Partitions

If you are in a multi-user restroom, toilet stalls have their own criteria for consideration. At least one of the stalls must be accessible. (213.3.1) If there are six toilet stalls or a combination of six toilets and urinals in a restroom, an ambulatory accessible stall must be provided, as well. (213.3.1) There are a few requirements for accessible stalls that oftentimes get overlooked. The *ADA Standards* require that the doors be self-closing. Door pulls must be installed on both sides of the door near the latch. (604.8.1.2, 604.8.2.2) Any coat hooks installed within accessible stalls must be placed within accessible reach ranges, ensuring they are no higher than 48 inches above the finish floor. The requirement for shelves is more specific; they must be installed at a height between 40 and 48 inches above the finish floor. (604.8.3)

Grab Bars

The detailed requirements for installing grab bars at accessible toilets are frequently overlooked. For new construction and recent renovations, grab bars are typically installed at accessible toilets. They are just installed at incorrect locations. This may be due to a lack of details in the construction documents or a contractor's failure to adhere to the details outlined in the drawings. Either way, it is a common problem in restrooms. For standard accessible toilets, two grab bars are required: a rear wall grab bar and a side wall grab bar. The top of the grab bars must be mounted between 33 and 36 inches above the finish floor. The *ADA Standards* do not specify that both grab bars be mounted at the same height, but it is advisable. The side wall grab bar must be a minimum of 42 inches long, located no more than 12 inches from the rear wall, and extend at least 54 inches from the rear wall. (604.5.1) If you do the math, a 42-inch-long grab bar would have to be installed exactly 12 inches off the rear wall to comply. It is advisable to specify a 48-inch grab bar to allow for some deviation. Ambulatory accessible stalls get two side wall grab bars that have the same dimensional requirements.

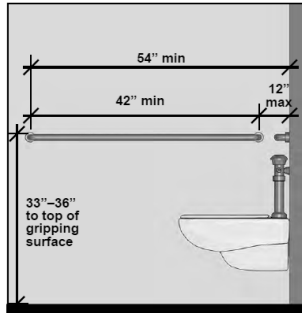

Side Grab Bar

Rear wall grab bars must be a minimum of 36 inches long. The location of the toilet determines its placement. From the centerline of the toilet, the rear wall grab bar must extend 12 inches in one direction and 24 inches in the other direction. (604.5.2) As with the side wall grab bar, it is advisable to specify a longer one to allow for an inexact installation.

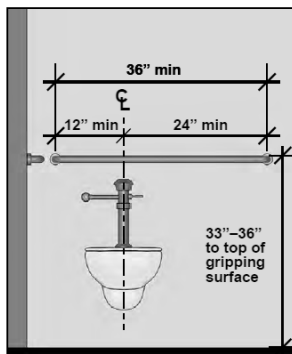

Rear Grab Bar

When toilet paper dispensers, toilet seat covers, shelves, and sanitary napkin disposal units are installed at toilets, the clearance requirements around grab bars are sometimes ignored. 1-1/2 inches of clearance below, behind, and to the sides of grab bars are required. A clearance of 12 inches is required above the grab bar. Installing recessed toilet accessories such as toilet paper dispensers provides better access because they keep the space around the grab bars clear.

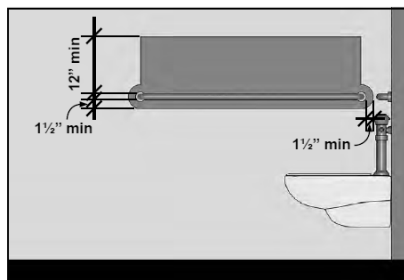

Minimum Clearance at Grab Bars

Toilets

Another common detail that is overlooked when installing accessible toilets is the placement of the flush controls. Hand-operated flush controls need to be located on the open side of the toilet. (604.6) It is recommended to include notes about the location on both the architectural and plumbing drawings.

The distance between the side wall or side partition and the centerline of the toilet gets flagged quite often. For wheelchair-accessible toilets, the required distance is 16 inches minimum and 18 inches maximum. The dimension in the prior code was 18 inches, and it is still used on many plans. It is recommended to dimension your toilets 17 inches from the side wall or partition, allowing 1 inch of wiggle room on either side during construction. At ambulatory accessible toilets, the required distance between the toilet and the side wall or partition is 17 to 19 inches. (604.2)

Paper towel dispensers are repeatedly installed in the clear floor space required for the toilets in single-user toilet rooms. The only items allowed to overlap the toilet are the associated grab bars, dispensers, sanitary napkin disposal units, coat hooks, shelves, accessible routes, clear floor space and clearances required at other fixtures, and the turning space. A paper towel dispenser and hand dryer are not associated with the toilet; therefore, they cannot be installed in the clear floor space required for the toilet. (604.3.2)

Due to the previous standards allowing it, sinks may also be seen in the clear floor space for toilets. However, this is not compliant with the *2010 ADA Standards*.

Baby Changing Tables

Baby changing tables seem to be an afterthought in their placement within many restrooms. They are often installed on leftover wall space, but this does not always work out in the design of an accessible restroom. They can become protruding objects, interfere with the clear floor space required at sinks, toilets, and doors, or be installed at an inappropriate height. When deciding where to place a changing table in a restroom, several key standards must be taken into consideration. A baby changing table is considered a work surface and must comply as such. Five percent must be accessible. (226.1) To be accessible, a clear floor space with knee and toe clearance is required. (902.2) The top of the changing table (work surface) must be between 28 and 34 inches above the finished floor. (902.3) The operable parts must be within accessible reach ranges, so they cannot be higher than 48 inches from the ground. (308.2) When stowed, they cannot overlap the required door clearances or the clear floor spaces required at the accessible plumbing fixtures. (404.2.4, 604.3.2) If they are in a circulation path, they cannot protrude from the wall more than 4 inches. (307.2)

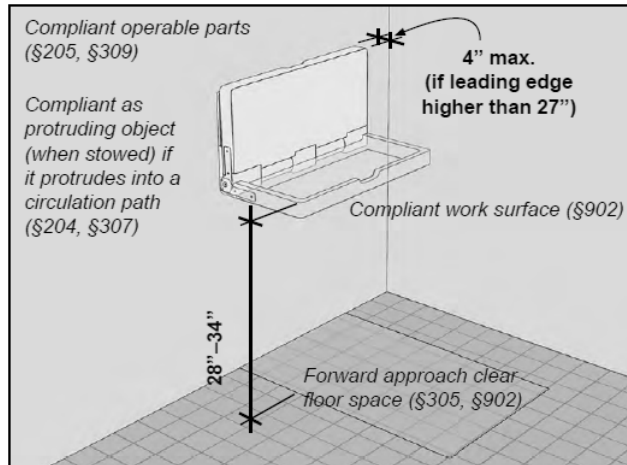

Changing Table Requirements

Review Questions

1. What is the maximum height a mirror above a sink or lavatory may be mounted?
 - a. The bottom edge of the frame may be mounted no higher than 36" above the finish floor.
 - b. The bottom edge of the reflective surface may be mounted no higher than 36" above the finish floor.
 - c. The bottom edge of the frame may be mounted no higher than 40" above the finish floor.
 - d. The bottom edge of the reflective surface may be mounted no higher than 40" above the finish floor.
2. What is the required length of a rear wall grab bar within an accessible toilet stall?
 - a. 24"
 - b. 30"
 - c. 36"
 - d. 42"
3. Which of the following may be installed in the clear floor space for an accessible toilet?
 - a. Baby changing table
 - b. Sink or lavatory
 - c. Paper towel dispenser
 - d. None of the above

Drinking Fountains and Bottle Fillers

Drinking fountains are often listed among common accessibility failures for several reasons. Often, a drinking fountain is installed that meets the requirements for wheelchair users, but access is also required for standing users. (211.2) So, if drinking fountains are going to be installed, at least two must be provided. If more than two are installed, 50 percent must be for wheelchair users, and 50 percent must be for standing users. (211.3) Another thing to note is that the scoping for drinking fountains must be applied separately to each floor of a building,

secured area, and exterior site. You cannot design only one drinking fountain for a specific area. The only exception given is for detention or correctional facilities. The drinking fountains that only serve holding or housing cells that are not required to have mobility features do not have to be accessible for wheelchair users. (211.1)

Another reason drinking fountains are on the list is because it is oftentimes forgotten that if a primary function area of a building is being renovated, the drinking fountains serving the renovated area must also be made accessible if they are not already. They are included on the list with the path of travel to the altered area, the restrooms, and the telephones. (202.4)

Bottle fillers are becoming common elements in buildings. Designers frequently assume that bottle fillers or water coolers can substitute one of the required drinking fountains. However, the *ADA Standards* do not allow this. Drinking fountains are not required where none are planned. If they are provided, they cannot be substituted with a bottle filler. Note that if bottle fillers are installed, they must be accessible by being on an accessible route, have a clear floor space (forward or side approach), have controls within an accessible reach range, and be usable with one hand and not require tight grasping, pinching, twisting of the wrist, or greater than 5 pounds of force to operate. If a bottle filler is being integrated with a hi-lo drinking fountain unit, it should be located in the wheelchair-accessible unit.

A drinking fountain can easily become a protruding object if it is not properly designed and installed. Remember that a protruding object has a leading edge greater than 27 inches and less than 80 inches above the finish floor and protrudes more than 4 inches into the circulation path. (307) For a wheelchair-accessible drinking fountain to meet the required knee clearance, the lower edge cannot be lower than 27 inches above the finished floor. If it is installed above 27 inches, it will be a protruding object if design provisions have not been made. Therefore, if the wheelchair-accessible drinking fountain is not designed to be installed within an alcove, it must be installed with the lower edge at precisely 27 inches above the finished floor to comply. Some manufacturers have started offering cane-touch aprons that can be attached to drinking fountains for standing individuals, but they must be specified. When designing an alcove, it must accommodate the clear floor space required for the accessible unit. Do not forget to increase the width of the clear floor space to 36 inches if the alcove is deeper than 24 inches.

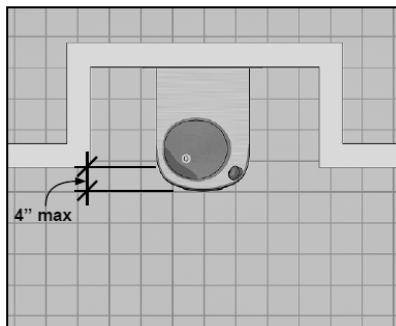

Drinking Fountain Protruding Object Limitation



Hi-Lo Drinking Fountain with Cane Touch Apron

Protruding Objects

Generally speaking, protruding objects are among the items that fail an accessibility inspection. Paper towel dispensers and hand dryers are common protruding objects in restrooms. Sinks, themselves, can be protruding objects. Fire extinguishers and AED cabinets are frequently located in circulation spaces and mounted in a way that makes them protruding objects. Even though the owner may install numerous protruding objects after a building is constructed, it is a good idea to inquire about any future installations on the walls and assist them in placing those items, so they do not have to relocate them later.



Protruding Object – Sink



Protruding Objects – AED Cabinet and Fire Extinguisher

Stairs and their horizontal handrail extensions are frequently noticed as protruding objects in existing buildings. If open stairways and/or their handrail extensions are located in the circulation path to a primary function area that is being renovated, they must be addressed. (202.4) The horizontal portion of a handrail may return to a support post at a height of 27 inches or less, ensuring it is within the detectable range of a cane. A barrier, such as a guardrail, planter box, or bench, may be designed under a stair where the vertical clearance is less than 80 inches to prevent an open stairway from becoming a protruding object.

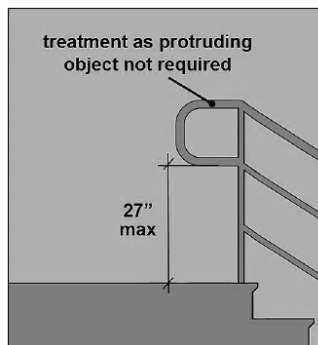

Horizontal Handrail Extension

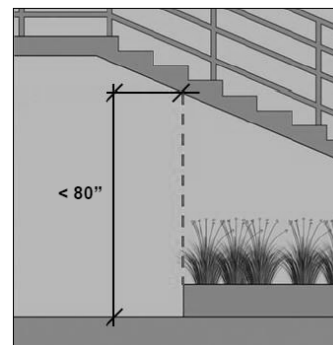

Stairway Barrier

Doors

Inaccessible doors continue to be noticed in new and renovation projects. At least 60 percent of all public entrances must be accessible. (206.4) At least one accessible door, doorway, or gate is required for each room that requires accessibility. (206.5) The most common violation is the failure to provide the required door maneuvering clearances. Several factors determine the maneuvering clearances, including the direction of the approach, the door swing, and the presence of a closer or latch. Table 404.2.4.1 in the *ADA Standards* lists the required clearances. A common mistake is missing keyed note 1. If a door is being approached from the front on the push side, an extra 12 inches of clearance is required beyond the latch if the door has both a closer and a latch. If the door has *only* a closer or a latch, an additional 12 inches of clearance is not required.

Table 404.2.4.1 Maneuvering Clearances at Manual Swinging Doors and Gates

Type of Use		Minimum Maneuvering Clearance	
Approach Direction	Door or Gate Side	Perpendicular to Doorway	Parallel to Doorway (beyond latch side unless noted)
From front	Pull	60 inches (1525 mm)	18 inches (455 mm)
From front	Push	48 inches (1220 mm)	0 inches (0 mm) ¹
From hinge side	Pull	60 inches (1525 mm)	36 inches (915 mm)
From hinge side	Pull	54 inches (1370 mm)	42 inches (1065 mm)
From hinge side	Push	42 inches (1065 mm) ²	22 inches (560 mm) ³
From latch side	Pull	48 inches (1220 mm) ⁴	24 inches (610 mm)
From latch side	Push	42 inches (1065 mm) ⁴	24 inches (610 mm)

1. Add 12 inches (305 mm) if closer and latch are provided.
2. Add 6 inches (150 mm) if closer and latch are provided.
3. Beyond hinge side.
4. Add 6 inches (150 mm) if closer is provided.

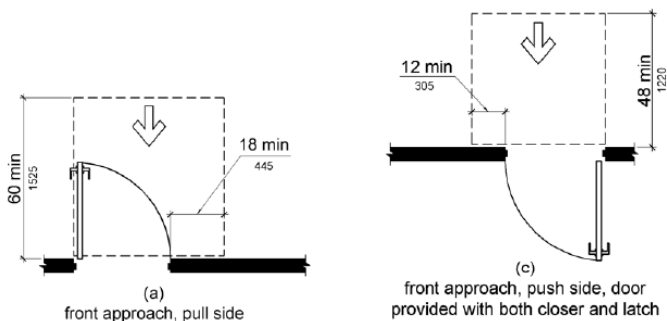
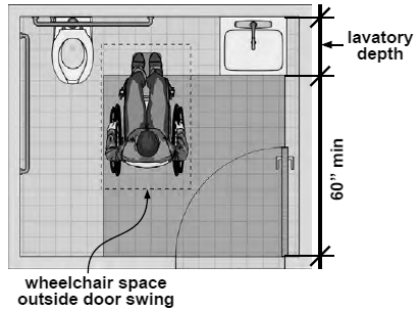
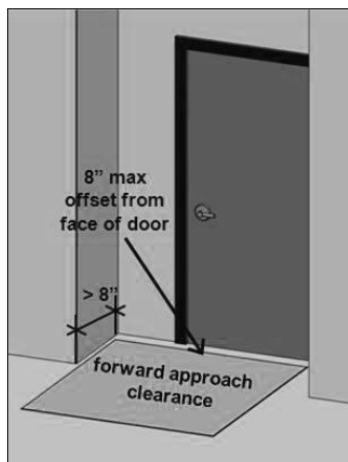

Figure 404.2.4.1 Maneuvering Clearances at Manual Swinging Doors and Gates

Another common maneuvering clearance miss is failing to provide 18 inches of clearance beyond the latch on the pull side of the door and 60 inches of clearance perpendicular to the door. This issue is seen frequently in single-user restrooms. Doors are not allowed to swing into the clear floor space required for a fixture unless a 30-inch by 48-inch clear floor space is provided beyond the door's swing. However, the door still requires adequate maneuvering clearances, as shown in the image. Hand dryers, paper towel dispensers, baby changing tables, sinks, and other fixed objects may not be placed in the required maneuvering clearances for the door up to a height of 80 inches. (404.2.4)



Recessed doors can sometimes be a design challenge. Doors may be recessed due to thick walls, adjacent casework, shelving, columns, and other building elements. When there is an obstruction within 18 inches of the latch side that projects more than 8 inches from the face of the door, forward approach maneuvering clearances have to be provided. (404.2.4.3)



Door vision lights and side lights are flagged quite frequently in projects. If they are meant to permit viewing, the bottom of at least one glazed panel must be located no higher than 43 inches above the finish floor. (404.2.11) Only doors with vision lights that have the lowest part more than 66 inches from the finished floor do not have to comply. The *ADA Standards* do not have an exception for vision lights in fire-rated doors that limit the amount of glazing.

When renovating a space, do not forget to consider the door hardware for the doors that allow entrance into the primary function spaces being renovated. A lot of older buildings still have door knobs that do not comply with the requirement to be operable with one hand and not require tight grasping, pinching, or twisting of the wrist. (309.4) Since the door is included in the path of travel to the renovated space, the hardware must be accessible. (202.4) Typically, the knobs are replaced with lever handles.

Path of Travel Elements

Path of travel elements are commonly neglected in renovation projects. Section 204.4 in the *ADA Standards* states that 'in addition to the requirements of 202.3, an alteration that affects or could affect the usability of or access to an area containing a primary function shall be made so

as to ensure that, to the maximum extent feasible, the path of travel to the altered area, including the restrooms, telephones, and drinking fountains serving the altered area, are readily accessible to an usable by individuals with disabilities, unless such alterations are disproportionate to the overall alterations in terms of cost and scope as determined under criteria established by the Attorney General. In existing transportation facilities, an area of primary function shall be as defined under regulations published by the Secretary of the Department of Transportation or the Attorney General. EXCEPTION: Residential dwelling units shall not be required to comply with 202.4.'

When owners budget renovation projects, they quite often want to limit renovations to a particular area in a building. They do not realize that they will not be able to limit their renovations to a specific area if they will be renovating a primary function area and the path of travel elements are not accessible. Unless your particular jurisdiction requires it, if the path of travel elements fully meet the requirements of a previous version of the *ADA Standards*, they will not be required to be renovated to meet the current standards. They qualify for safe harbor.

What, exactly, are primary function areas? They are defined as areas of a building or facility containing a major activity for which the building or facility is intended. They may be public use and employee use areas. So, dining areas in restaurants, exam rooms in a doctor's office, and classrooms at a school would all be considered primary function areas. The following areas are generally not considered primary function areas: mechanical rooms, boiler rooms, supply storage rooms, employee lounges or locker rooms, janitorial closets, entrances, corridors, and restrooms. However, if the restrooms at a rest stop are being renovated, they would be considered a primary function area.

The path of travel must go from the site arrival points to the altered primary function area. This includes public sidewalks, parking, and passenger loading zones. Inside the building, it includes clear floor paths through lobbies, corridors, and elevators/lifts. The restrooms, telephones, and drinking fountains serving the altered primary function area are included in the path of travel that must be accessible. One thing to note is that if a tenant is making alterations to their space, it does not trigger a path of travel obligation upon the landlord.

If the cost of making the path of travel elements accessible is disproportionate to the cost and scope of the overall alterations, they may not need to be addressed fully. Some jurisdictions require a variance to claim disproportionality. Disproportionate is considered as exceeding 20 percent of the total cost of the alterations to the primary function area. Making the path of travel elements accessible is required up to the point where the 20 percent cost amount is reached. The order in which the path of travel elements is prioritized is:

1. An accessible entrance
2. An accessible route to the primary function area
3. At least one accessible restroom for each sex or a single unisex restroom
4. An accessible telephone
5. An accessible drinking fountain
6. Access to other elements such as parking, storage, and alarms

Performing a series of small renovations to an area is not an acceptable method for avoiding the provision of an accessible path of travel. Any renovations undertaken within three years of the original alteration must be considered in determining cost disproportionality.

The path of travel requirements are not fully listed in the *2010 ADA Standards for Accessible Design*. They may be found in *the DOJ's ADA Standards at 28 CFR Part 35.15(b) (Title II) and 28 CFR Part 36.403 (Title III), and in the DOT's ADA Regulation at 49 CFR Part 37.43.*

Parking

Parking is on the list of common violations because it does not require you to go inside a building to be seen. It is included in the path of travel, so it is inspected during renovation projects to primary function areas. When conducting a formal accessibility inspection, common accessible parking concerns include the number provided, the location of parking spaces, the size of parking spaces and access aisles, the absence of access aisles, incorrect or inadequate signage, improper curb ramp locations, and excessive slopes.

The required number of accessible parking spaces is determined by the overall number of parking spaces for each facility. The key word is 'each'. Each parking lot and parking structure must be calculated separately. Table 208.2 in the *ADA Standards* is used to calculate the required number of spaces. Hospital outpatient facilities, rehabilitation facilities, outpatient physical therapy facilities, and residential facilities are calculated differently. 10 percent of patient and visitor parking spaces serving hospital outpatient facilities must be accessible. (208.2.1) 20 percent of patient and visitor parking spaces for rehabilitation facilities must be accessible. Rehabilitation facilities specialize in treating conditions that affect mobility, including those requiring the use of mobility aids, neurological conditions, respiratory diseases, and cardiac conditions. (208.2.2) At residential dwelling units, the calculation depends on whether at least one parking space is provided for each unit. If each unit has at least one space, each residential dwelling unit that is required to provide mobility features must have an accessible parking space. If there are more resident parking spaces than units, 2 percent of the spaces must be accessible. The number of accessible spaces for guest lots is determined by Table 208.2.

Table 208.2 Parking Spaces

Total Number of Parking Spaces Provided in Parking Facility	Minimum Number of Required Accessible Parking Spaces
1 to 25	1
26 to 50	2
51 to 75	3
76 to 100	4
101 to 150	5
151 to 200	6
201 to 300	7
301 to 400	8
401 to 500	9
501 to 1000	2 percent of total
1001 and over	20, plus 1 for each 100, or fraction thereof, over 1000

For every six, or fraction thereof, accessible parking spaces that are required to comply, one must be a van-accessible space. (208.2.4)

Accessible parking spaces must be located on the shortest accessible route from the parking facility or lot to the accessible entrance of the building they serve. If there are multiple accessible entrances, the accessible parking spaces need to be dispersed among the accessible entrances. If a parking facility or lot supports multiple buildings or facilities, accessible parking must be located on the shortest accessible route to an accessible pedestrian entrance. There are a couple of exceptions to this. Van parking spaces can be put on one level of a parking garage. If equivalent or greater accessibility can be provided by grouping accessible parking spaces together in different parking lots or facilities, it is also allowed. (208.3.1) Accessible parking spaces serving an accessible residential dwelling unit, such as an apartment, must be located on the shortest accessible route to the unit. (208.3.2)

Sometimes, accessible parking spaces are not sized correctly. The spaces are supposed to be measured from the centerline of the markings. If the space being measured is not adjacent to another parking space or access aisle, the measurement can include the full width of the line. A standard accessible space must be 8 feet wide. A van-accessible space must be 11 feet wide and have a vertical clearance of 8 feet 2 inches. Both types of accessible spaces are required to have an adjacent access aisle that is at least 5 feet wide, connected to an accessible route of travel, and marked to discourage parking in them. (502)

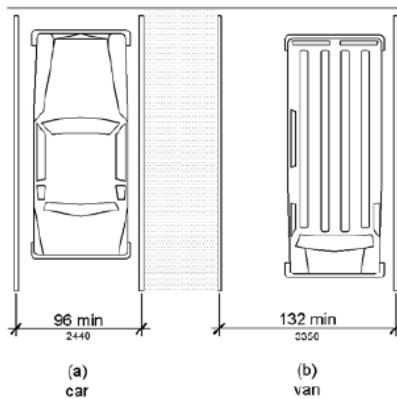

Figure 502.2
Vehicle Parking Spaces

As an alternate, a van-accessible space could be the same width as a standard accessible space, provided the access aisle serving it is increased to 8 feet in width. (502) Vans need the extra space to accommodate ramps and lifts.



Van Accessible Space

When designing accessible parking spaces, it is essential to remember that the access aisles cannot slope more than 1:48. The access aisles must be connected to an accessible route. If it

involves a curb ramp, no part of the curb ramp may be within the access aisle. A curb ramp must have a running slope of no more than 1:12, a cross slope of no more than 1:48, and a clear width of at least 36 inches. If the curb ramp has flared sides, the sides must not have a slope greater than 1:10. A 36-inch deep landing is required at the top of the curb ramp.

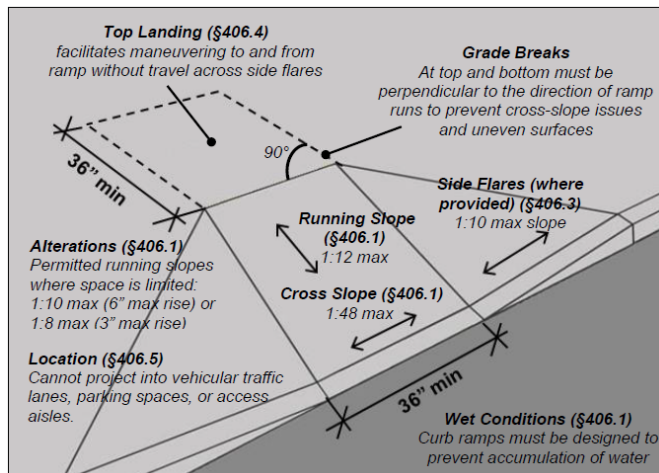

Curb Ramp

Sometimes, accessible parking spaces are only designated with pavement markings. They must be designated with signs. The signs are required to include the International Symbol of Accessibility. Van-accessible parking space signs must have the words “van accessible” on them. The bottom of the signs must be mounted at least 60 inches above the ground so they may be seen over vehicles parked in the spaces. (502.6) Local jurisdictions often have additional requirements beyond the ADA Standards; therefore, it is essential to check your local requirements as well.

Summary

Overall, this course aimed to expand your knowledge of some common pitfalls in accessibility compliance. It provided insight into why specific design elements are problematic and offered some solutions along the way. To recap:

1. Install a sink so that the *higher* of the sink rim or counter surface does not exceed 34 inches.
2. Cover all plumbing under the sink with insulation or panels that allow adequate knee clearance.
3. Mount toilet accessories such as soap and paper towel dispensers so that their controls are within accessible reach ranges.
4. When mirrors are mounted above a sink in restrooms, install the lower edge of the reflective surface no higher than 40 inches above the finish floor.
5. Provide adequate clear floor space (30 inches x 48 inches) at urinals. If a urinal is in an alcove deeper than 24 inches, increase the clear floor space width to 36 inches.

6. In restrooms, specify self-closing doors at toilet partitions that have door pulls on both sides of the door. Install coat hooks no higher than 48 inches above the finish floor and shelves between 40 and 48 inches.
7. Consider specifying longer grab bars than required to allow for an inexact installation.
8. Install flush controls on the open side of the toilet.
9. Dimension toilets at 17 inches from the centerline to the side partition or wall to allow for field deviations.
10. Do not design paper towel dispensers or sinks in the clear floor space for toilets.
11. Detail baby changing tables so that when open, the work surface is mounted between 28 and 34 inches from the finished floor, and there are no operable parts higher than 48 inches. Locate them so that they are not protruding objects and do not overlap fixture clear floor spaces. Please do not put them in the maneuvering clearance required for a door.
12. Provide drinking fountains for both standing and wheelchair users. Install cane detection if they are located on a circulation path and not within an alcove.
13. Do not substitute bottle fillers for drinking fountains. Install bottle fillers with controls that are within accessible reach ranges.
14. Provide care with locating items that will be in circulation paths to ensure they do not protrude from the wall more than 4 inches if they are positioned between 27 and 80 inches above the finished floor unless cane detection is provided.
15. Design adequate door maneuvering clearances that are clear of objects. If a door is being approached from the front on the push side, do not forget to provide 12 inches of clearance beyond the latch if the door will have both a closer and a latch. If a door is being approached on the pull side, provide 18 inches of clearance beyond the latch and 60 inches of clearance perpendicular to the door.
16. Place the lower edge of vision lights in doors no higher than 43 inches above the finish floor unless it is higher than 66 inches. Replace door knobs with lever handles on doors to spaces being renovated.
17. When designing alterations to a primary function area, do not forget to address any inaccessible path of travel elements from the site arrival to the area of alterations, including restrooms, telephones, and drinking fountains.
18. Provide accessible parking for every lot/facility on a site. Design spaces that are at least 8 feet wide with an adjacent 5-foot access aisle. For every six (6) accessible spaces, or fraction thereof, provide one (1) van accessible space that is 3-foot wider than a standard accessible space. The additional 3-foot could be added to either the parking space or the access aisle.
19. Do not place curb ramps in accessible parking access aisles. Design them at least 36 inches wide with a slope of no greater than 1:12, a cross slope not exceeding 1:48, and any flares not exceeding 1:10. Provide a 36-inch deep landing at the top.
20. Install accessible parking signs at accessible parking spaces that include the International Symbol of Accessibility and have 'VAN ACCESSIBLE' where applicable. Mount the lower edge of the signs at least 60 inches above the ground.

Review Questions

4. What is the required width of a standard accessible parking space?
 - a. 8'
 - b. 9'
 - c. 10'
 - d. 11'

5. How many accessible parking spaces are required at a hospital outpatient facility lot that has a total of 350 parking spaces?
 - a. 8
 - b. 35
 - c. 70
 - d. All of them

Answers – Review Questions

1. What is the maximum height a mirror above a sink or lavatory may be mounted?
 - a. The bottom edge of the frame may be mounted no higher than 36" above the finish floor.
 - b. The bottom edge of the reflective surface may be mounted no higher than 36" above the finish floor.
 - c. The bottom edge of the frame may be mounted no higher than 40" above the finish floor.
 - d. **The bottom edge of the reflective surface may be mounted no higher than 40" above the finish floor.**

Explanation: Section 603.3 states that mirrors located above lavatories or countertops shall be installed with the bottom edge of the reflecting surface 40 inches maximum above the finish floor or ground.

2. What is the required length of a rear wall grab bar within an accessible toilet stall?
 - a. 24"
 - b. 30"
 - c. **36"**
 - d. 42"

Explanation: Section 604.5.2 states that the rear wall grab bar shall be 36 inches long minimum.

3. Which of the following may be installed in the clear floor space for an accessible toilet?
 - a. Baby changing table
 - b. Sink or lavatory
 - c. Paper towel dispenser
 - d. **None of the above**

Explanation: Section 604.3.2 states that the required clearance around the water closet shall be permitted to overlap the water closet, associated grab bars, dispensers, sanitary napkin disposal units, coat hook, shelves, accessible routes, clear floor space and clearances required at other fixtures, and the turning space. No other fixtures or obstruction shall be located within the required water closet clearance.

4. What is the required width of a standard accessible parking space?
 - a. **8'**
 - b. 9'
 - c. 10'
 - d. 11'

Explanation: 502.2 states that car parking spaces shall be 96 inches (8 feet) wide minimum.

5. How many accessible parking spaces are required at a hospital outpatient facility lot that has a total of 350 parking spaces?
 - a. 8
 - b. **35**
 - c. 70
 - d. All of them

Explanation: Section 208.2.1 states that 10% of patient and visitor parking spaces provided to serve hospital outpatient facilities shall comply with the standards for accessible parking.

10% of 350 is 35.