



Architects

Simplifying the ADA

Course Number: AIAPDH241
5 LU|HSW

PO Box 449 Pewaukee, WI 53072 (888) 564-9098

arch-support@edcet.com

ANSWER SHEET

First Name: _____ Last Name: _____ Date: _____

Address: _____ City: _____ State: _____ ZIP: _____

Phone: _____ Email: _____

AIA #: _____

** See instructions on the cover page to submit your exams and pay for your course.

Simplifying the ADA Final Exam

- | | | | | |
|--------------------|---------------------|---------------------|---------------------|---------------------|
| 1. (A) (B) (C) (D) | 7. (A) (B) (C) (D) | 13. (A) (B) (C) (D) | 19. (A) (B) (C) (D) | 25. (A) (B) (C) (D) |
| 2. (A) (B) (C) (D) | 8. (A) (B) (C) (D) | 14. (A) (B) (C) (D) | 20. (A) (B) (C) (D) | 26. (A) (B) (C) (D) |
| 3. (A) (B) (C) (D) | 9. (A) (B) (C) (D) | 15. (A) (B) (C) (D) | 21. (A) (B) (C) (D) | |
| 4. (A) (B) (C) (D) | 10. (A) (B) (C) (D) | 16. (A) (B) (C) (D) | 22. (A) (B) (C) (D) | |
| 5. (A) (B) (C) (D) | 11. (A) (B) (C) (D) | 17. (A) (B) (C) (D) | 23. (A) (B) (C) (D) | |
| 6. (A) (B) (C) (D) | 12. (A) (B) (C) (D) | 18. (A) (B) (C) (D) | 24. (A) (B) (C) (D) | |

Simplifying the ADA Final Exam

- The primary difference between Title II regulations and Title III regulations of the 2010 ADA Standards, is that Title II establishes _____ for _____.**
 - Guidelines, commercial facilities
 - Laws, facilities built with public funds
 - Guidelines, facilities built with public funds
 - Laws, commercial facilities
- If the building cannot be made accessible to wheelchairs, accessibility _____.**
 - Must still be provided for persons with other types of disabilities
 - Is no longer mandatory for that structure
 - Must be provided at a later date if a building occupant becomes disabled
 - Can be provided in a separate structure
- When considering required accessibility alterations, a _____ is defined as a major activity for which the facility was created.**
 - Use classification
 - Primary function
 - Point of service
 - Work activity
- In portions of residential buildings being used for commercial purposes, portions used by _____ must still comply.**
 - Residents in mobility aids
 - The public
 - Visitors of residential tenants
 - Anyone requiring a service animal
- Unless exempted elsewhere, how many accessible parking spaces must be provided in a parking facility with 51-75 total spaces?**
 - 5
 - 1
 - 3
 - 7
- Raised shapes providing a detectable warning on a walk surface will be in a _____ shape.**
 - Recessed dimple
 - Raised bar
 - Truncated dome
 - Flattened pyramid
- A required accessible primary entrance to a residential dwelling unit, may not enter a _____.**
 - Bedroom
 - Great room
 - Shared vestibule
 - Dining room
- When an accessible route turns 180 degrees around an element with at least 60" of clear width at the turn, the approach to the turn must be at least _____ wide.**
 - 36"
 - 42"
 - 48"
 - 60"
- On accessible routes less than _____ wide, passing spaces will be provided less than _____ apart.**
 - 60", 200'
 - Two wheelchairs, 60 feet
 - 36", 60'
 - Two wheelchairs, 200 feet
- Handrails for adults must be _____ above the surface, another for children can be _____ high.**
 - 33"-36", 26"-28"
 - 34"-38", 26"-28"
 - 34"-38", 28"
 - 42", 18"
- No projections are allowed into required clear openings, lower than _____ above the floor.**
 - 34"
 - Handle height
 - 36"
 - 27"
- A distance of at least _____" should be maintained between two hinged or pivoted doors or gates in series.**
 - 60
 - 48
 - 36
 - 32

13. Space between the finish surface and 9" above that surface is considered _____.
 a. Unusable for clearance
 b. Storage space, if covered
 c. Swing space
 d. Toe clearance
14. Objects 27"-80" above finish floor, can protrude only _____" into a circulation path.
 a. 4
 b. 6-9
 c. 2
 d. 4½
15. Elevator control buttons shall be identified by tactile characters, with raised character and braille designations immediately to the _____ of the control button they designate.
 a. Left
 b. Right
 c. Top
 d. Bottom
16. _____ wheelchair spaces are required in an assembly area having 301-500 seats
 a. 2
 b. 6
 c. 8
 d. 5
17. Licensed facilities, where patient stays exceed 24 hours, must _____.
 a. Make all parking spaces accessible.
 b. Provide accessible sleeping rooms
 c. Provide overnight accommodations for companions
 d. Have centralized nursing stations
18. Where work surfaces are provided for non-employees, at least _____% will be accessible.
 a. 7½
 b. 10
 c. 5
 d. 2
19. Renovation of general holding and housing cells need not include accessible cells, unless that is required by the _____.
 a. Jail administrator
 b. Prisoner advocacy council
 c. Attorney General
 d. A professional negotiator
20. Where visible doorbell signals are in sleeping areas, they will have _____.
 a. A remote response to allow access without rising
 b. Controls to deactivate the signal
 c. A strobe that slowly increases in intensity
 d. An easily removeable cover
21. Accessible dressing rooms should have bench seats installed _____ high.
 a. 17"-19"
 b. Knee
 c. 14"-16"
 d. 2" below wheelchair seat
22. The sound level of audible notification appliances will be no more than _____.
 a. 10dB above ambient noise
 b. 110dB
 c. 3500Hz
 d. 95dB
23. The firmer the carpeting and backing, the _____.
 a. Lower the roll resistance
 b. Less future maintenance required.
 c. Less likely it is to be perceived as real carpet
 d. More expensive to purchase
24. To remain accessible, vertical changes in levels not including a bevel, can be no higher than _____".
 a. 3/16"
 b. 1/8"
 c. ½"
 d. ¼"
25. Where a sand box is provided, an accessible route must connect to _____.
 a. The principle play area entry
 b. The bottom of the sandbox
 c. The base of the nearest slide
 d. The sand box border
26. If 14-16 elevated play components are provided, there must also be a minimum of _____ ground level components on an accessible route.
 a. 3
 b. 5
 c. 7
 d. 8

CONTINUING EDUCATION for Architects

Simplifying the ADA

5.0 PDH / 5 CE Hours / 5 AIA LU/HSW

AIAPDH241

IN THIS COURSE YOU WILL:

1. Identify who must comply with accessible laws and standards.
2. Be made aware of many acceptable methods of achieving accessibility for existing buildings.
3. Understand the scoping and technical requirements for accessibility to sites, facilities, buildings and elements by individuals with disabilities.
4. Learn the importance of compliance with the ADA.

SERIES INTRO

Purpose

In September of 2010, the U.S. Department of Justice published a comprehensive set of standards on designing buildings to facilitate their use by the handicapped. The regulations were titled “2010 ADA Standards for Accessible Design.” The acronym referred to the “Americans with Disabilities Act,” previously passed in 1990. The publication clarified what was being requested from designers by the earlier legislation. It included 275 pages of suggestions, including some graphic illustrations showing how to meet requested design goals.

We will look at those ADA standards and illustrations, and summarize as best as possible how to meet their intent.

APPLICABILITY OF GUIDELINES

The 2010 ADA Standards for state and local governments was created to explain minimum requirements for access to buildings by occupants with handicaps. One section was written as laws, applicable to newly designed, constructed or altered, state and local government facilities. The second portion contained similar provisions, intended as guidelines for designing public accommodations and commercial facilities, making them readily accessible to, and usable by, individuals with disabilities.

The first portion consisted of Title II regulations 28 CFR 35.151 and the 2004 ADAAG at 36 CFR part 1191, appendices B and D. These specific guidelines established laws governing facilities built with public funds, enforceable with all such facilities built after March 15, 2012.

The 2010 Standards for public accommodations and commercial facilities, the second portion of same publication, set guidelines for buildings for public use, built by private entities. They consisted of Title III regulations at 28 CFR part 36, subpart D, and the 2004 ADAAG at 36 CFR part 1191, appendices B and D. These were suggested guidelines only.

The two sets of guidelines and their subject content are almost identical. The primary difference lies in enforceability. Guidelines are much different than building codes: one offers suggestions while the other creates law. That distinction being made, almost all jurisdictions, when adopting model codes, incorporated some or all of the 2010 Standards for public accommodations and commercial facilities into their regulations. At that point, such guidelines became law.

Other regulations governing accessible design have also been published. Some are more stringent than the 2010 Standards. Jurisdictions can and have adopted other model guidelines. But suffice it to say, almost no jurisdiction with building regulations has failed to include laws governing accessible design. Those laws seem to have become more stringent with each new edition of regulations, and in some cases, now exceed original guidelines proposed in the ADA.

Accessibility requirements apply to both temporary and permanent facilities. Temporary facilities can include: reviewing stands, temporary classrooms, bleacher areas, stages, platforms, fixed furniture systems, wall systems, exhibit areas, temporary banking facilities and temporary health screening facilities.

Some exceptions to these rules exist, which will be touched upon later. One broad group of exceptions applies to renovation and addition projects, when it is desirable to make previously built facilities more accessible, but budget considerations preclude full compliance. Another group of exceptions involves renovation of historic structures. If compliance would destroy the historic value of an existing structure, some variation from guidelines is permitted.

GLOSSARY OF TERMS

Terms used in these guidelines are defined as follows.

Accessible: A site, building or facility that complies with the ADA rules / guidelines.

Accessible Means of Egress: A continuous, unobstructed accessible way of egress from any point in a building to an area of refuge, a horizontal exit or a public way.

Addition: A project resulting in expanding or increasing the floor area or height of a building.

Administrative Authority: A government agency adopting and enforcing regulations and guidelines for design and construction of buildings or additions.

Alteration: A physical change affecting the usability of a building or a portion thereof. Alterations may include: remodeling, renovation, rehabilitation, reconstruction, historic restoration, resurfacing circulation paths or vehicular ways, changes or rearrangement of structural elements and changes in the plan configuration of walls and full-height partitions. Normal maintenance, reroofing, painting, wallpapering or changes to mechanical and electrical systems are not alterations, unless they affect the usability of the building.

Amusement Attraction: Any facility located within an amusement or theme park, providing amusement without the use of an amusement device. Amusement attractions include, but are not limited to, fun houses, barrels and other attractions without seats.

Amusement Ride: A system moving people through a fixed course to provide amusement.

Amusement Ride Seat: A seat fastened to an amusement ride, to be occupied by passengers.

Area of Sport Activity: A space where play or practice of a sport occurs.

Assembly Area: A space, used for the purpose of entertainment, educational or civic gatherings or similar purposes. These include, but are not limited to, classrooms, lecture halls, courtrooms, public meeting

rooms, public hearing rooms, legislative chambers, motion picture houses, auditoria, theaters, playhouses, dinner theaters, concert halls, centers for the performing arts, amphitheaters, arenas, stadiums, grandstands or convention centers.

Assistive Listening System (ALS): An amplification system between a sound source and a listener, using an induction loop, radio frequency, infrared or direct-wired equipment.

Boarding Pier: A portion of a pier used to embark or disembark from a boat.

Boat Launch Ramp: A sloped surface to launch and retrieve trailered boats from water.

Boat Slip: A portion of a pier where a boat is moored for berthing, embarking or disembarking.

Building: Any structure supporting or sheltering any use or occupancy.

Catch Pool: A section of a pool used as a terminus for water slide flumes.

Characters: Letters, numbers, punctuation marks and typographic symbols.

Children's Use: A use designation for elements intended for people 12 years old and younger.

Circulation Path: An exterior or interior passage used for pedestrian travel, including but not limited to walks, hallways, courtyards, elevators, platform lifts, ramps, stairways and landings.

Closed-Circuit Telephone: A telephone with a dedicated line, used to gain entry to a facility.

Common Use: Interior or exterior circulation elements, not for public use, but made available for shared use by two or more occupants.

Cross Slope: A slope perpendicular to the direction of travel.

Curb Ramp: A short ramp cutting through a curb, or built up to it.

Detectable Warning: A surface feature built in, or applied to walking surfaces, to provide a tactile warning of potential hazards on a circulation path.

Element: An architectural or mechanical component of a building, facility, space or site.

Elevated Play Component: A raised or lowered component that is part of a composite play structure, having two or more play components linked together.

Employee Work Area: Space used only by employees for work. Corridors, toilet rooms, kitchenettes and break rooms are not employee work areas.

Entrance: Any access point to a building used to enter it. An entrance includes the approach walk, vertical

access leading to the entry platform, the entry platform, vestibule if provided, entry door or gate and the hardware of the door or gate.

Facility: Any or all portions of buildings and improvements located on a site.

Gangway: A variable-sloped pedestrian walk linking a fixed point with a floating structure.

Golf Car Passage: A passage on which a golf cart operates.

Ground Level Play Component: A play component approached and exited at ground level.

Key Station: Rapid, light and commuter rail stations, as defined by the Dept. of Transportation.

Mail Boxes: Receptacles for documents, packages or other deliverable materials.

Marked Crossing: A crosswalk or other path for pedestrian use, crossing a vehicular way.

Mezzanine: An intermediate level between the floor and ceiling of any story, having a floor area less than one-third of the space in which the mezzanine is located, with enough height above it that space for human occupancy can be provided on the floor below.

Occupant Load: The possible number of facility occupants for egress points to accommodate.

Operable Part: Items used to insert or withdraw objects, activate, deactivate or adjust elements.

Pictogram: A pictorial symbol representing activities, facilities or concepts.

Play Area: A site location containing play components

Play Component: An element generating opportunities for play, socialization or learning.

Private Building or Facility: A place of public accommodation or a commercial building or facility subject to title III of the ADA and 28 CFR part 36, or a transportation building or facility subject to title III of the ADA and 49 CFR 37.45.

Public Building or Facility: A building designed for use by a public entity, subject to title II of the ADA and 28 CFR part 35, or to title II of the ADA and 49 CFR 37.41 or 37.43.

Public Entrance: An entrance that is neither a service entrance, nor a restricted entrance.

Public Use: Interior or exterior rooms or spaces made available to the public.

Public Way: Any street, alley or other parcel of land, open to the outside air and leading to a dedicated public street, having a clear width and height of not less than 10 feet.

Qualified Historic Building or Facility: A building listed in, or eligible for listing in, the National Register of Historic Places, or legally designated as being historic.

Ramp: A walking surface with a slope steeper than 1:20.

Residential Dwelling Unit: A unit designed for use as a long-term residence. Residential dwelling units do not include those for transient lodging, inpatient medical care, licensed long-term care and detention or correctional facilities.

Restricted Entrance: A non-public entrance used on a controlled basis or for service.

Running Slope: The slope that is parallel to the direction of travel.

Self-Service Storage: Buildings used for the purpose of renting or leasing individual storage spaces to customers, to be accessed on a self-service basis.

Service Entrance: An entrance intended primarily for delivery of goods or services.

Site: A parcel of land bounded by a property line, including those of rights-of-way.

Soft Contained Play Structure: An enclosed play structure made of pliable materials like plastic.

Space: A defined area, like a room, toilet room, hall, assembly area, entrance, etc.

Story: A portion of a building between the upper surface of a floor and the upper surface of a floor or roof above. A story containing mezzanines has more than one floor level.

Structural Frame: The columns, girders, beams and trusses stabilizing the building as a whole.

Tactile: An object that can be perceived using the sense of touch.

Technically Infeasible: With respect to altering a building, something with little likelihood of being accomplished because it would require removing or altering a load-bearing member, or because other existing physical constraints prohibit modifying or adding elements, spaces or features in full and strict compliance with minimum requirements.

Teeing Ground: In golf, the starting place from which a hole is played.

Transfer Devices: Equipment to facilitate transfer between a mobility aid and another location.

Transient Lodging: A building with guest room accommodations that are short-term in nature. Transient lodging does not include actual residences, inpatient medical care facilities, licensed long-term care facilities, detention or correctional facilities or private buildings with not more than five rooms for rent that are also occupied as a residence by the proprietor.

Transition Plate: A sloping pedestrian walking surface at the end of a gangway.

TTY: An abbreviation for teletypewriter. TTYS are also called text telephones.

Use Zone: Level ground area beneath and adjacent to play structures or equipment for moving around equipment, and where a user would land when falling from or exiting equipment.

Vehicular Way: A route intended for vehicular traffic, like a street, driveway or parking facility.

Walk: An exterior surface for pedestrian use, including pedestrian areas like plazas and courts.

Wheelchair Space: Space for a single wheelchair and its occupant.

Work Area Equipment: Any machine, instrument, engine, motor, pump, conveyor or other apparatus used to perform work, permanently installed or built-in inside employee work areas. Work area equipment does not include passenger elevators and other vertical transportation.

Here is an overview of the first section, creating laws governing the design of public structures.

28 CFR PART 35.151 NEW CONSTRUCTION AND ALTERATIONS

This initial portion of the guidelines opens with this statement.

“Each facility or part of a facility constructed by, on behalf of, or for the use of a public entity, shall be designed and constructed in such manner that the facility, or part of the facility, is readily accessible to and usable by individuals with disabilities.”

Compliance Dates

Regarding compliance with these guidelines or laws, all time frames in which a building might have been exempted have long since expired. All new projects must now comply.

Scope of Coverage

The 1990 ADA and the 2010 Standards apply to fixed or built-in elements of buildings, structures, site improvements, pedestrian routes or vehicular ways located on a site. Unless stated otherwise, advisory notes, appendix notes and illustrations contained in the 1990 ADA and the 2010 Standards explain or illustrate requirements of the rule. These ancillary materials, intended for clarification, do not in and of themselves establish enforceable requirements.

Exceptions

Some needed exceptions to these laws were immediately recognized and written into the act.

Exception for Structural Impracticality

New public facilities must be accessible in whole or in part to those with disabilities, but:

- Full compliance with accessibility laws is not required when unique characteristics of terrain prevent incorporating accessibility features. A public entity must demonstrate how full compliance is impossible, before provisions are waived.
- Although covered entities can limit the scope of an alteration to individual elements, renovating multiple elements within a room or space in the same project is usually a more cost-effective way to make the entire room or space accessible.
- Even if full compliance cannot be accomplished in a specific instance, any portion of a building that can be made fully accessible must still meet requirements.
- If the building cannot be made accessible to wheelchairs, accessibility must still be possible for persons with other types of disabilities (who use crutches, have sight, hearing, or mental impairments, etc.) in accordance with regulations.

Exception for Historic Properties

Alterations to existing facilities must be made so the altered portions have been made accessible.

- Public entities are obligated to achieve accessibility under ADA regulations and those operating historic preservation programs must give priority to methods providing physical access to the disabled.
- When an entity believes compliance for accessibility will threaten or destroy historic significance, they should consult with the State Historic Preservation Officer. If that officer agrees, the exception will be permitted. Path of travel requirements still need to be met, even when renovating for other purposes than creating accessibility.
- If alterations would endanger historical significance, fundamentally alter the program, or result in undue financial or administrative burdens, regulations allow alternative methods to achieve accessibility. These include using audio-visual materials to depict inaccessible portions of the building or relocating programs and services to accessible locations.
- Alterations to historic buildings should comply with pertinent provisions, when possible.
- If it is not feasible to provide physical access to a historic property, without threatening or destroying historic significance, other means of access can be provided.

Exception for Alterations to Primary Functions

Alterations affecting usability of, or access to, an area housing a primary function need to be made so—to the maximum extent possible—the path of travel to altered areas, and restrooms, telephones and drinking fountains serving the altered area, all remain accessible.

- A primary function is a major activity for which the facility was created.
- Such functions include; dining areas in cafeterias, meeting rooms in conference centers, offices and other work areas housing primary activities.
- Where a facility contains multiple primary uses, each portion must comply.
- Mechanical rooms, boiler rooms, supply storage rooms, employee lounges / locker rooms, janitorial closets, entrances and corridors are not areas for primary functions.
- Restrooms are not primary functions, other than for structures like highway rest stops.
- Alterations to windows, hardware, controls, electrical outlets and signage are not deemed to affect usability of areas with primary functions.
- Mixed use facilities may include numerous primary function areas to which regulations apply, not limited to public use areas. For example, both a bank lobby and the bank's employee areas, like teller areas and a walk-in safe, are primary function areas.
- In existing transportation facilities, primary functions are defined under regulations published by the Secretary of the Department of Transportation or the Attorney General.
- Residential dwelling units are exempt from these regulations.

Defining the Path of Travel

A “path of travel” includes a continuous, unobstructed pedestrian passage through which an area may be approached, entered and exited. It also encompasses exterior features like: sidewalks, streets, parking areas and facility entries. An accessible path of travel can include: walks and sidewalks, curb ramps, interior or exterior ramps; paths through lobbies, corridors, rooms, parking access aisles, elevators and lifts or a combination of these elements. It may also encompass restrooms, telephones and drinking fountains, serving the altered area.

- An alteration decreasing accessibility of a building or facility that is below the requirements for new construction at the time of the alteration, is prohibited.
- An alteration of a facility will not impose greater requirements for accessibility than new construction.
- Unless required elsewhere, where elements or spaces are altered, but the circulation path to the altered element or space is not changed, an accessible route will not be required.

Exception for Disproportionality

Alterations providing an accessible path of travel are considered disproportionate to overall alterations when

their cost exceeds 20% of the cost to alter the primary function area.

- If making an accessible path of travel is disproportionately expensive, changes to that path can be scaled back to match the budget.
- When scaling back, priority should be made in the order of: an accessible entrance, an accessible route to altered areas, at least one accessible restroom for each sex or a single unisex restroom, accessible telephones, accessible drinking fountains and then additional accessible elements like parking, storage and alarms.
- Path of travel costs include costs to create a more accessible route, like widening doorways or installing ramps.
- The cost of making restrooms accessible, by installing grab bars, enlarging toilet stalls, insulating pipes or installing accessible faucet controls is included.
- Money spent to make telephones accessible can be included.
- So can relocating a previously inaccessible drinking fountain.
- If alterations can be made in one project, providing an accessible path of travel cannot be avoided by breaking a project into small enough scopes that the cost of accessibility becomes disproportionate.
- A budget for project costs will include any alterations made in a three year period.

Requirements Pertaining to Specific Building Types

A few specific requirements for certain public building types were included in the first section.

Social Service Centers

This includes: group homes, halfway houses, shelters or similar establishments providing either temporary sleeping accommodations or residential dwelling units. In these:

- Sleeping rooms with 25 beds or more will provide clear floor space for at least 5% of them.
- Facilities with 50 beds or more and common bathing facilities will have at least one roll-in shower with a seat. Transfer type showers are not a substitute. When there are separate showers for men and women, at least one roll-in shower must be provided for each group.

Educational Housing

Housing at a place of education must meet the same requirements as transient lodging guest rooms, with the term “sleeping room” used interchangeably with “guest room.” In these:

- Kitchens in units with accessible sleeping rooms, including suites and clustered sleeping rooms, or common kitchens on floors with accessible sleeping rooms, will contain turning spaces and kitchen work surfaces needed for accessibility.
- Multi-bed housing with accessible sleeping rooms needs an accessible route throughout.
- Apartments or townhouses, leased year-round exclusively to graduate students or faculty, but not containing public use areas for instruction, are not subject to transient lodging standards. They must still comply with requirements for residential facilities.

Assembly Areas

Besides other requirements for assembly areas, the following is also required:

- In stadiums, arenas and grandstands, wheelchair spaces and companion seats will be available in all levels served by an accessible route and cannot be located on, or obstructed by, temporary platforms or other movable structures, except:
 - When an entire seating section is added on temporary platforms to increase seating for an event, wheelchair spaces and companion seats can be placed in that section.
 - When wheelchair spaces and companion seats are not required to accommodate handicapped users, removable seats can be set in spaces they would have occupied.
- Accessible seating will wholly or partially encircle a field of play or performance area.
- Stadium-style movie theaters must locate wheelchair spaces and companion seats on a riser or cross-aisle, satisfying at least one of these criteria:
 - Located in the rear 60% of total seats in the auditorium.
 - Located so their vertical viewing angles (as measured to the top of the screen) are from the 40th-100th percentile of vertical viewing angles for all seats.
 - In row seating, companion seats shall provide shoulder alignment with adjacent wheelchair spaces, with the alignment point of the wheelchair space measured 36” from the front of the wheelchair space. The floor surface of the companion seat will be at the same elevation as the floor of the wheelchair space.
 - Companion seats are permitted to be movable.

Medical Care Facilities

If medical care facilities do not specialize in the treatment of conditions that affect mobility, they must still provide required accessible patient bedrooms.

28 CFR PART 36, SUBPART D - NEW CONSTRUCTION AND ALTERATIONS

This part of the act established guidelines for buildings built with private funds, and also opens with this statement:

“Each facility or part of a facility constructed by, on behalf of, or for the use of a public entity shall be designed and constructed in such manner that the facility or part of the facility is readily accessible to and usable by individuals with disabilities.”

The standards that followed are starting points for handicap accessibility codes, whether model codes, legislated codes or legislated codes referencing model codes. Accessibility guidelines and laws have continued evolving since the initial publication of this act. This has been largely due to advocacy and legislative input from special interest groups representing handicapped segments of our population, as well as advances in technologies available for their use.

Most exceptions granted in the section for public buildings were included in this portion, with a few notable additions to allowable exemptions.

Additional Exemptions

Exemption for General Alterations

Alterations should be made so a path of travel to altered areas, and restrooms, telephones and drinking fountains serving the altered area, remain accessible to the maximum extent feasible.

- Alterations include remodeling, renovation, rehabilitation, reconstruction, historic restoration, changes to structural elements and changes in plan configuration of walls.
- Normal maintenance, reroofing, painting or wallpapering, asbestos removal or changes to mechanical and electrical systems not affecting usability, are not considered alterations.
- Alterations to windows, hardware, controls, electrical outlets and signs don't affect use.
- The phrase “to the maximum extent feasible,” applies when planned alterations make it virtually impossible to comply fully with accessibility standards.

Exemption for Disproportionality

Alterations need to be made so paths of travel to primary functions remain accessible. Changes made to create an accessible path of travel are considered disproportionate to overall alterations when their cost exceeds 20% of the cost of primary function renovations.

- If costs are disproportionate, path changes can be scaled back to match the budget.
- If scaling back, changes should be prioritized in this order: an accessible entrance, an accessible route to altered areas,

- All areas of such a facility must comply unless exempted, or where scoping limits the number of multiple elements required to be accessible.
- For example, not all patient rooms are required to be accessible, thus not required to comply with requirements. However, common use and public spaces, like recovery rooms, examination rooms and cafeterias, are not exempt and must be accessible.

Curb Ramps

New or altered streets, roads and highways must contain curb ramps at any intersection with curbs or other barriers denying entry to handicapped pedestrians.

Housing with Units for Sale to Individuals

Residential dwelling units constructed or altered by public entities, then offered for sale or rent to individuals, must comply with requirements for residential facilities found in the ADA.

These also apply to public housing, when construction of units takes place once a specific buyer has been identified. Accessible units must be provided to pre-identified buyers with disabilities.

Detention and Correctional Facilities

Except for the following exceptions, new jails, prisons and other correctional facilities must comply, whether or not such facilities are licensed.

- Public entities must provide accessibility in a minimum of 3%, but no fewer than one, of the total cells in a facility.
- Cells with mobility features must also be provided in each classification level.
- Common areas used only by inmates or detainees and security personnel, not serving accessible holding or housing cells, need not comply or be on an accessible route.

Renovated jails, prisons, and other detention and correctional facilities must also comply, with the same exceptions noted above. However, when cells are being altered, the required number of accessible cells can be met by providing cells elsewhere, provided each substitute cell:

- Is located within the same prison site
- Is integrated with other cells as much as possible
- Has equal access as other cells to areas for visitation, dining, recreation, education programs, medical services, work programs, religious and other facility programs.
- If it is infeasible to locate a substitute cell in the same prison, a substitute cell must be provided at another prison site in the same corrections system.

at least one accessible restroom for each sex or a single unisex restroom, accessible telephones, accessible drinking fountains and then where possible, additional accessible elements like parking, storage and alarms.

- Path of travel costs include expenses to create more accessible routes to altered areas, like widening doorways or installing ramps and those making restrooms accessible with grab bars, enlarging toilet stalls, insulating pipes or installing accessible faucet controls.
- Money spent to make telephones accessible can be included, as can relocating a previously inaccessible drinking fountain.
- If alterations can be made in one project, providing an accessible path of travel cannot be avoided by breaking a project into small enough scopes that the cost of accessibility becomes disproportionate.
- A budget for project costs will include any alterations made in a three year period.

Exemption for Historic Preservation

If compliance would destroy historic value, variation from guidelines is permitted, especially if providing physical access to the property would threaten the historic significance of the building.

Exemption for Commercial Facilities in Private Residences

Building portions used for commercial purposes must comply. Those for residential use are exempt.

- Accessibility regulations still apply to sidewalks, entries, hallways, bathrooms, etc. used by the public, entering the commercial portion.

Exemption Regarding Elevators

Elevators are not required in facilities with less than three stories, or less than 3000 SF. But elevator access is still required for:

- Floors housing at least one sales or rental establishment, in a building or cluster of buildings housing five or more such stores, also known as a shopping center.
- Any floor housing at least one professional office of a health care provider.
- Terminals, depots or other stations for specified public transit. This includes airport terminals, unless areas housing passenger services (including boarding and debarking, loading and unloading, baggage claim, dining facilities and other common areas open to the public) are all located on an accessible route from an accessible entrance.

When facilities are exempt from elevator requirements, they must still be accessible.

Exemption for Construction Sites

Structures and equipment used in actual construction processes need not be accessible.

- These may include scaffolds, bridging, hoists, materials storage and construction trailers.
- Portable toilet units for use by construction personnel need not comply.

Exemption for Raised Areas

Raised areas used for security, life safety or fire safety, like observation or lookout galleries, prison guard towers, fire towers or life guards need not be accessible or on an accessible route.

Exemption for Limited Access Spaces

Spaces accessed by ladders, catwalks, crawl spaces or narrow passages need not comply.

Exemption for Machinery Spaces

Service spaces for maintenance, repair or occasional monitoring of equipment need not be on an accessible route or accessible. Machinery spaces like elevator pits or penthouses; mechanical, electrical or communication equipment rooms; piping or equipment catwalks; water or sewage treatment pump rooms and stations; electric substations and transformer vaults; and highway and tunnel utility facilities need not comply.

Exemption for Single Occupant Structures

Single occupant structures like toll booths, accessed only by passages that are elevated or below grade, shall not be required to be accessible or on an accessible route.

Exemption for Residential Facilities

Common use areas not serving accessible residential dwelling units need not comply.

Exemption for Employee Work Areas

Employee work areas shall be built so individuals with disabilities can approach, enter and exit work areas. But work areas or portions of work areas other than raised courtroom stations, less than 300 SF and elevated 7" or more above the floor and where being raised is essential to the space function, need not comply or be on an accessible route.

Though areas used exclusively for work need not be fully accessible, include non-required turning spaces and accessible elements when possible. Under the ADA, employees with disabilities are entitled to reasonable accommodations in the workplace. Those can include alterations to facility spaces. Initially designing employee work areas to be more accessible can avoid more costly retrofits if current employees become disabled or the disabled are hired.

Exemption for Raised Refereeing, Judging, and Scoring Areas

Raised structures for refereeing, judging or scoring sports need not be accessible.

Exemption for Water Slides

Water slides shall not be required to be accessible or on an accessible route.

Exemption for Animal Containment Areas

Animal containment areas not for public use need not comply or be on an accessible route. Public circulation routes by animals, like petting zoos and animal pens in fairs, must comply.

Exemption for Raised Boxing or Wrestling Rings

Raised boxing or wrestling rings shall need not comply or be on an accessible route.

Exemption for Raised Diving Boards and Diving Platforms

Raised diving boards and diving platforms need not comply or be on an accessible route.

Exemption for Protruding Objects

Protruding objects on circulation paths shall comply with guidelines, except:

- In areas of sport activities, protruding objects on circulation paths need not comply.
- In play areas, protruding objects on circulation paths need not comply, provided ground level accessible routes provide vertical clearance that complies.

Exemption for Operable Parts

Controls generally required to be accessible may include: light switches, circuit breakers, duplexes and other receptacles, environmental and appliance controls, plumbing fixture controls and security and intercom systems. Operable parts on accessible elements, accessible routes and in accessible rooms and spaces shall comply with guidelines, except:

- Operable parts for use only by service or maintenance personnel need not comply.
- Electrical or communication receptacles serving a dedicated use need not comply.
- When two or more outlets are above a length of kitchen counter, uninterrupted by a sink or appliance, one outlet need not comply.
- Floor electrical receptacles need not comply.
- HVAC diffusers need not comply.
- Except for light switches, where redundant controls are provided for a single element, one control in each space need not comply.
- Cleats and other boat securement devices need not comply.
- Exercise machines and exercise equipment need not comply.

GRAPHIC STANDARDS

The following standards are applicable to illustrations included in this course.









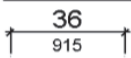

Convention	Description
	dimension showing English units (in inches unless otherwise specified) above the line and SI units (in millimeters unless otherwise specified) below the line
	dimension for small measurements
	dimension showing a range with minimum - maximum
min	minimum
max	maximum
>	greater than
≥	greater than or equal to
<	less than
≤	less than or equal to
	boundary of clear floor space or maneuvering clearance
	centerline
	a permitted element or its extension
	direction of travel or approach
	a wall, floor, ceiling or other element cut in section or plan
	a highlighted element in elevation or plan
	location zone of element, control or feature

Figure 104
Graphic Convention for Figures

review questions...

1. **When do guidelines for accessibility become laws?**
 - a. When enforced by inspectors who have a copy of the federal laws
 - b. When punitive damages for non-compliance are awarded in civil lawsuits
 - c. After the last exempt building has been grandfathered in.
 - d. When adopted into the regulations of jurisdictions.
2. **Apartments or townhouses, leased year-round exclusively to graduate students or faculty, are not subject to transient lodging standards when _____.**
 - a. They have multiple bedrooms in each unit
 - b. They do not contain public use areas for instruction
 - c. They are used only for visiting alumni
 - d. No current or foreseeable tenants are handicapped.
3. **In residential facilities, common use areas that _____ need not comply with accessibility requirements.**
 - a. Contain less than an aggregate area of 3000 SF on one level
 - b. Remain locked unless reserved beforehand for use
 - c. Contain only laundry equipment
 - d. Do not serve accessible units

A PLACE TO PARK

The goal of this section will be to examine ADA standards, maximizing user accessibility in getting to a facility. It will examine navigating vehicular parking, successfully exiting and entering parked vehicles and physically getting to a facility entry.

Parking Space Requirements

A portion of provided parking spaces are required to meet accessibility standards. But parking used exclusively for buses, trucks, delivery vehicles, law enforcement and vehicular impound need not comply, so long as publicly accessed lots have an accessible loading zone.

Percentages of Spaces Required to be Accessible

Accessible parking spaces must be provided per the table below, unless exempted elsewhere.

Table 208.2 Parking Spaces

Total Number of Parking Spaces Provided in Parking Facility	Minimum Number of Required Accessible Parking Spaces
1 to 25	1
26 to 50	2
51 to 75	3
76 to 100	4
101 to 150	5
151 to 200	6
201 to 300	7
301 to 400	8
401 to 500	9
501 to 1000	2 percent of total
1001 and over	20, plus 1 for each 100, or fraction thereof, over 1000

- Where more than one parking facility is provided on a site, accessible spaces required on the site will be calculated separately for each parking facility.
- Both “parking facilities and “parking lots” are subject to compliance.

Varying Percentages for Different Uses

The use of a facility determines how many available spaces will need to be accessible.

- At hospital outpatient facilities, 10 % of patient and visitor parking spaces will be designed to be accessible. “Outpatient facility” is not defined, but covers facilities located in hospitals, providing regular and continuing treatment without an overnight stay.
- Doctors’ offices, independent clinics or other facilities not in hospitals are not outpatient.
- At rehabilitation and outpatient physical therapy facilities, 20 % of patient and visitor parking spaces serving facilities treating conditions affecting mobility will be accessible. Conditions affecting mobility

include those: requiring assistance of a brace, cane, crutch, prosthetic device, wheelchair, or powered mobility aid; arthritic, neurological or orthopedic conditions severely affecting walking; respiratory diseases and other conditions requiring use of portable oxygen; and cardiac issues imposing limitations.

- Where at least one space is provided for each dwelling unit, one accessible space must be provided for each dwelling unit with accessibility features. When more parking spaces are provided than one per unit, 2% of additional spaces, with a minimum of one additional space, must be accessible.
- When parking is provided for more than residents, provide parking per the table above.
- For every six spaces or fraction thereof required by the table to be accessible, at least one will be an accessible van parking space.

Location of Parking Facilities

Grouping of Accessible Spaces

- Accessible spaces should be as close as possible to an accessible entrance.
- If such spaces do not serve a particular facility, they should be as close as possible to an accessible pedestrian entrance of the parking facility.
- All van spaces should be grouped on one level in a multi-story parking facility.
- Accessible spaces can be distributed to better serve different entry points, reduce parking fee, or increase user convenience. This is based on factors like: protection from the weather, security, lighting and better lot maintenance.

Passenger Loading Zones

- Passenger loading zones will offer a vehicular space at least 96” wide and 20’ long.
- Passenger loading zones will provide access aisles adjacent to the vehicle pull-up space, adjoining the accessible route, but not overlapping the vehicular way.
- Access aisles serving vehicle pull-up spaces shall be at least 60” wide.
- Access aisles will extend the length of vehicle spaces they serve and be marked.
- Access aisles will be at the same level as the vehicle space they serve. Changes in level are not permitted, unless they are less than a slope of 1:48.
- Vehicle pull-up spaces, access aisles and the vehicular route from entry to passenger loading zone to

vehicular exit shall provide a vertical clearance of at least 114”.

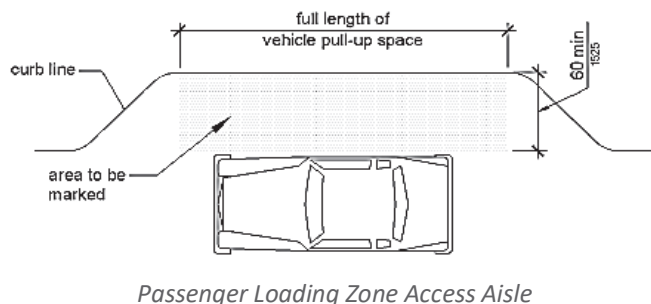

Physical Characteristics of Parking Facilities

Parking Lot Dimensions

- Width measurements of parking spaces and access aisles will be from centerlines of markings, unless spaces or access aisles are not adjacent to another parking space or aisle. Then, measurements can include the full width of the line defining the space or aisle.
- Accessible car parking spaces will be at least 96” wide and van parking spaces at least 132” wide, marked to define the width, with an adjacent access aisle for off-loading. Van parking spaces can be 96” wide, when the access aisle is at least 96” wide.

Access Aisles

Access aisles will adjoin an accessible route connected to an accessible entrance.

- Two parking spaces may share a common access aisle.
- In parking facilities where the accessible route crosses vehicular traffic lanes, marked crossings enhance pedestrian safety for people using wheelchairs and other mobility aids.
- The accessible route should not pass behind parked vehicles.

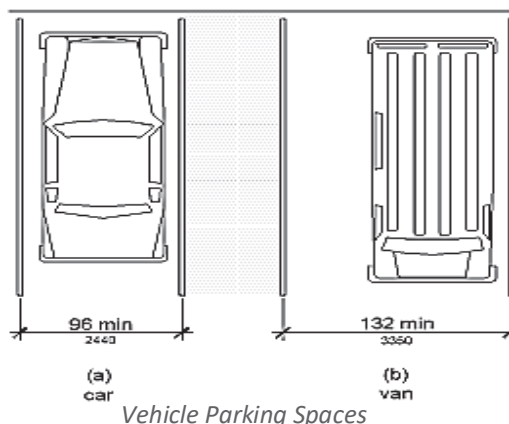

- Access aisles serving car and van spaces will be at least 60” wide, extend the full length of parking spaces they serve and be marked to discourage parking within them.
- Marking methods and colors are not specified, but may be addressed by other regulations.
- Access aisles shall not overlap vehicular traffic.
- Access aisles can be placed on either side of a parking space, except angled van spaces which will have access aisles located on the passenger side of the parked vehicle.

Public Transportation Stops

- “Designated public transportation” refers to vehicles operated by public transit agencies.
- “Specified public transportation” includes tour and charter buses, taxis, limousines and hotel shuttles operated by private entities.
- Provide one accessible passenger loading zone for every 100 LF of loading zone space.
- In bus loading zones for designated or specified public transportation vehicles, each bus bay, bus stop or other area designated for lift or ramp deployment must be accessible.
- On-street bus stops will be made accessible to the maximum extent practicable.

Residential Facility Parking

- Accessible spaces will be as close as possible to the units they serve.
- Accessible spaces will be dispersed throughout all types of provided parking facilities.
- Accessible parking need not be dispersed if better accessibility can be provided in terms of distance to accessible entrances, parking fees or increased user convenience, based on factors like: protection from the weather, security, lighting and better lot maintenance.

Medical and Long-Term Care Facility Parking

- At least one accessible passenger loading zone will be provided at an entry to licensed medical facilities where a period of stay can exceed 24 hours.
- Facilities providing valet services will provide at least one accessible loading zone.
- Mechanical access parking garages will provide at least one accessible loading zone at vehicle drop-off and pick-up areas.

- Wheelchair lifts are usually installed on the passenger side of vans, which are harder to back into parking spaces than out into vehicular lanes. So if a van and car share an access aisle, locate the van space so the access aisle is on the passenger side of the van.
- Changes in level in access aisles are not permitted, unless the slope is greater than 1:48.
- Built-up curb ramps are not permitted to project into access aisles and parking spaces because they would create slopes greater than 1:48.

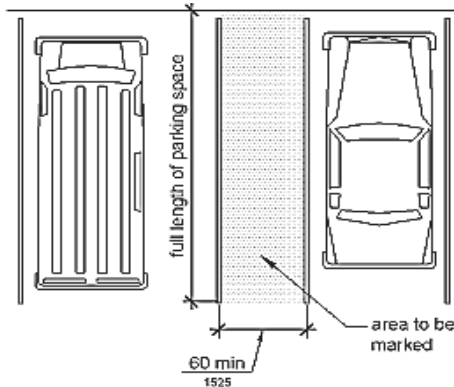

Parking Space Access Aisle

Additional Parking Lot Considerations

- Van parking spaces, access aisles and vehicle routes will provide 98" vertical clearance.
- Parking facility signage will inform drivers of clearances and the location of van spaces.
- Accessible parking signs will include the International Symbol of Accessibility, signs identifying van spaces will include the words "Van accessible," and bottoms of such signs shall be at least 60" above the finish floor or ground surface.
- Parked cars and vans will not obstruct required clear widths of adjacent accessible routes.
- Wheel stops prevent vehicle overhangs from reducing the accessible route clear widths.

review questions...

4. Passenger loading zones will offer a vehicular space at least _____.
 - a. 96" wide and 20' long
 - b. Twice as long as the longest vehicle used.
 - c. 10' wide and 19' long
 - d. Long enough to park two vehicles
5. The minimum width of access aisles serving car and van spaces will be _____.
 - a. 60"
 - b. 9'
 - c. 32"
 - d. The same as the widest adjacent space.

A PATH TO TREAD

The goal of this section will be to look at ADA standards governing how to physically move from parking areas to front entries of facilities.

Accessible Routes

Site Arrival Points

At least one accessible route shall be provided from accessible parking, passenger loading zones, public streets, public sidewalks or public transportation stops to an accessible building entrance.

- Such a route is not required if the only means of access between a site arrival point and a building is a vehicular way with no pedestrian access.
- Otherwise, every accessible building entry must connect to an accessible route.
- Access routes into a building from site arrival points may include vehicular ways.
- The required space for a sport activity may vary from sport to sport, but an accessible route is required to connect to the boundary of each area of sport activity on a site.

Detectable Warnings on a Route

Detectable warnings on walk surfaces will be a surface of truncated domes as defined below.

- Truncated domes in a detectable warning surface will have a base diameter of 0.9"-1.4", a top diameter of 50%-60% of the base diameter and a height of 0.2".
- The domes will have a center-to-center spacing of 1.6"-2.", and a base-to-base spacing of at least 0.65", measured between adjacent domes on a square grid.

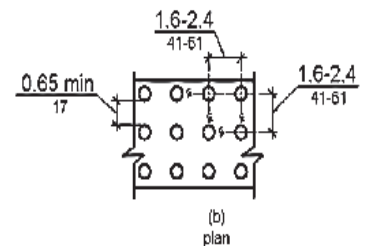
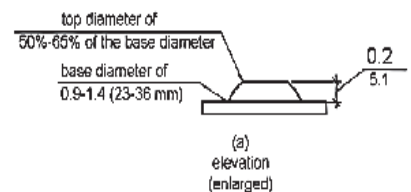

- Detectable warning surfaces will contrast visually with adjacent walking surfaces.
- Detectable warning surfaces *Size and Spacing of Truncated Domes* at platform boarding edges will be 24" wide and extend the full length of the public use areas of the platform.

Multi-Story Buildings and Facilities

At least one accessible route will connect every story and mezzanine in multi-story facilities.

- An accessible route will not be required in private facilities with less than three stories and less than 3000 SF per story, unless the facility has a shopping center, shopping mall, office of a health care provider, terminal, depot or other station for public transportation, an airport terminal or another facility as determined by the Attorney General.
- If a two story building has one level without public use and less than five occupants, that level need not be connected to the other.
- If all accessible cells, common areas used by those cells and public use areas are linked by an accessible route, additional stories in detention facilities need not be connected.
- If all accessible living units, common use areas used by them and public use areas are linked by an accessible route, additional stories in living facilities need not be connected.
- If all accessible lodging rooms units, common use areas used by them and public use areas are connected by an accessible route, additional stories in multi-story transient lodging facilities need not be connected.
- An accessible route is not required between the cab and the floor below the cab in an air traffic control tower.
- Accessible routes connecting stories above or below an accessible level are not required in qualified historical facilities granted exceptions for alterations.

Spaces and Elements

An accessible route will connect accessible facility entrances to all accessible spaces and elements in a facility connected by a circulation path, unless exempted above or below.

- Raised courtroom stations, like judges' benches, clerks' stations, bailiffs' stations, deputy clerks' stations and court reporters' stations do not need vertical access, if required clear floor and maneuvering space and electrical service are put in place to accommodate a future lift, should one become necessary. Public areas like jury boxes must still comply.
- In assembly areas with fixed seats, accessible routes are not required to where accessible seating will not be provided. Raised areas and speaker platforms must still be accessible.
- Accessible routes shall not be required to connect mezzanines in facilities having only one story, or in multi-story facilities otherwise exempted.

Stairs and Escalators in Existing Buildings

When structural modifications are made to add an escalator or stairway to a facility, an accessible route shall be provided between levels, unless otherwise exempted.

Restaurants and Cafeterias

In eating establishments, an accessible route will be provided to all dining areas, including raised or sunken dining areas and outdoor dining areas.

- In facilities not requiring an accessible route between stories, one will not be required to a mezzanine containing less than 25 % of the total combined area for dining.
- In alterations, an accessible route is not required to existing raised or sunken dining areas, or outdoor dining, if the same services and decor are provided in an accessible space.
- In sports facilities, tiered levels containing at least 25% of the dining area and accessible seating must have accessible routes, provided that each tier provides the same services.
- "Same services" may include bar service, rooms with smoking and non-smoking sections, lotto and other table games, carry-out and buffet service.
- "Same decor" may include seating with views, areas designed with a certain theme, party and banquet rooms and rooms where entertainment is provided.

Performance Area Circulation

If already connected, an accessible route will connect assembly seating with a performance area.

- An accessible route will be provided from performance areas to ancillary areas or facilities used by performers, unless otherwise exempted.
- Press boxes in each assembly area will be on an accessible route, unless boxes for that assembly area are in bleachers entered only at one level and all boxes are less than 500 SF, or boxes are elevated at least 12' above grade and all boxes contain less than 500 SF.

Employee Work Area Circulation

- Circulation paths within employee work areas, less than 1000 SF and defined by permanently partitions, counters, casework or moveable furnishings, need not comply.
- Circulation paths within employee work areas that are an integral component of work area equipment, like stairs and elevated walks, need not comply.
- Circulation paths in work areas fully exposed to the weather need not comply.

- Passenger elevators used to move workers between stories are not work area equipment.

Amusement Ride Accessibility

- At least one load and unload area must be on an accessible route.
- When amusement rides are in the load and unload position, their accessible wheelchair spaces, amusement ride seats for transfer and transfer devices will be on an accessible route.

Other Recreational Facilities Required to be on Accessible Routes

- Recreational boating facilities, boat slips and boarding piers at boat launch ramps shall be on accessible routes.
- In bowling establishments, at least 5 % but no fewer than one of each type of bowling lane must be on an accessible route.
- In court sports, at least one accessible route will directly connect both sides of the court.
- Exercise equipment required to be accessible will be on an accessible route.
- Fishing piers and platforms shall be on an accessible route.
- Within golf facilities, at least one accessible route will connect accessible elements within the golf course. They will also serve golf car rental, bag drop areas, course weather shelters, course toilet, practice putting greens, practice teeing grounds and teeing stations at driving ranges.
- Within miniature golf facilities, holes required to be accessible, including the start of play, shall be on an accessible route.
- Play areas shall provide at least one accessible route connecting accessible ground and elevated play components, including entry and exit points of the play components.
- Where three or less entry points are provided for soft contained play structures, at least one entry point must be on an accessible route. Where four or more entry points are provided, at least two must be on an accessible route.

Accessible routes will coincide with, or be in the same area as, general circulation paths. Where circulation paths are interior, accessible routes shall also be interior. Additionally, accessible vertical circulation must be in the same area as stairs and escalators, not isolated in the back.

Entrances

Entries on Accessible Routes

- When an entry is being renovated and the building has another accessible entry on an accessible route, unless required elsewhere, the entry being altered need not comply.
- Where exceptions are granted for alterations to historic buildings, only one public entry will be required to be accessible. If none can comply, either an unlocked private entrance will be accessible, or a locked accessible entry with a notification system will be used.
- In addition to above requirements, at least 60 % of all public entrances will be accessible.

Parking Structure Entrances

Where direct access is provided for pedestrians from a parking structure to a facility entrance, each such entrance will be accessible. If from a pedestrian tunnel or elevated walkway, at least one such entrance to a facility from each tunnel or walkway will be accessible.

Entries to Transportation Facilities

- Where different entrances serve different transportation fixed routes, at least one public entrance serving each fixed route or group of fixed routes shall be accessible.
- Direct connections to other facilities will provide an accessible route from points of connection to boarding platforms and all system elements required to be accessible, except for existing direct connections being retrofitted.
- Key stations and existing intercity rail stations required to be altered by other regulations shall have at least one accessible entrance provided.

Tenant Spaces

There shall be at least one accessible entrance to each tenant in a facility, but self-service storage facilities not required to be accessible need not comply.

Residential Dwelling Unit Entries

In residential dwelling units, at least one primary entrance, not to a bedroom, must be accessible. In accessible dwelling units, all doors and doorways providing user passage will be accessible.

Specialized Entries to Other Facilities

- Where restricted entrances are provided to a facility, at least one must be accessible.
- If a service entrance is the only entry to a building or tenant space, it must be accessible.
- Where entrances used only by detainees and security personnel are provided at judicial, detention or correctional facilities, at least one entry must be accessible.

Doors, Doorways, and Gates

Entrances

Each facility required to be accessible will have at least one accessible door, doorway or gate. Each space required to be accessible will have at least one accessible door, doorway or gate.

Transient Lodging Facilities

In transient lodging facilities, entrances, doors and doorways into and within guest rooms will have a clear passage width of 32". Shower and sauna doors are not required to be that wide.

Elevators and Lifts

Elevators

All elevators provided for passenger use shall be accessible.

- In facilities permitted to use platform lifts, limited-use / limited-application (LULA) elevators can also be used.
- LULA elevators are permitted in multi-story residential dwelling units.
- When an existing elevator is altered, all elevators programmed to respond to the same hall call control as the altered elevator must be altered in a similar fashion.

Platform Lifts

- Platform lifts will be permitted in an accessible route in new construction in an existing facility, or as a way to access performance areas and speakers' platforms.
- Platform lifts will be permitted in an accessible route complying with performance area requirements for wheelchair space dispersion and line-of-sight issues.
- Platform lifts shall be permitted in an accessible route to incidental spaces which are not public use spaces and occupied by a maximum of five people.
- Platform lifts shall be permitted in an accessible route to: jury boxes and witness stands; raised courtroom stations like judges' benches, clerk stations, bailiff stations, deputy clerk stations and court reporters' stations; and to depressed areas like the well of a court.
- Platform lifts can be used where existing site constraints like topography make using a ramp or elevator infeasible. Though necessitated by site problems, such a lift can be installed in an interior location, connecting two interior floor levels.
- Platform lifts can connect levels within transient lodging guest rooms or dwelling units required to accommodate the handicapped.
- Platform lifts can facilitate accessible load and unload

areas serving amusement rides.

- Platform lifts can create accessible routes to play components or soft play structures.
- Although ramps are recommended, platform lifts can provide accessible routes to team or player seating areas serving areas of sport activity.
- Platform lifts shall be permitted instead of gangways in accessible routes serving recreational boating facilities, fishing piers and platforms.

Security Barriers

Security barriers, including security bollards and security check points, may not obstruct a required accessible route or means of egress. Where security barrier elements make compliance difficult, like metal detectors, fluoroscopes, etc., an accessible route can be adjacent to screening devices. This allows disabled persons bypassing security barriers to maintain visual contact with personal items, as the able-bodied passing through security can do.

Accessible Means of Egress

- Means of egress will comply with applicable sections of other building codes.
- Where allowed by other codes, accessible means of egress can share a common path with another means of egress.
- Areas of refuge are not required in detention and correctional facilities.
- Platform lifts will have standby power when part of an accessible means of egress.

Accessible Routes

Accessible routes will consist of one or more of the following: walking surfaces with a slope less than 1:20, doorways, ramps, curb ramps excluding flared sides, elevators and platform lifts.

Walking Surfaces

- The running slope of walking surfaces will be no steeper than 1:20, and the cross slope no steeper than 1:48.
- Changes in walking surface levels must still be accessible.
- Walking surfaces will provide a clear width of at least 36", except that in employee work areas, circulation path clearances can be decreased by work equipment if the decrease is essential to work being performed.
- Clear widths can also be reduced to a minimum of 32" for a length of 24", if segments of reduced width are separated by sections that are at least 48" long and 36" wide.

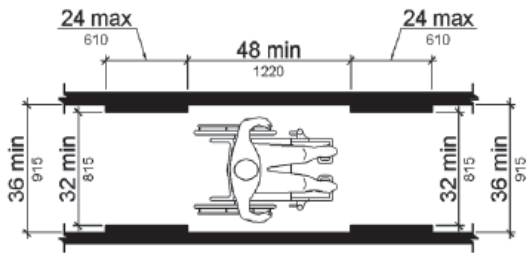

Clear Width of an Accessible Route

Clear Width at Turn

If an accessible route turns 180 degrees around an element less than 48" wide, the clear width shall be at least 42" approaching the turn, 48" at the turn, and 42" leaving the turn. If there is at least 60" of clear width at the turn, only a 36" approach is required.

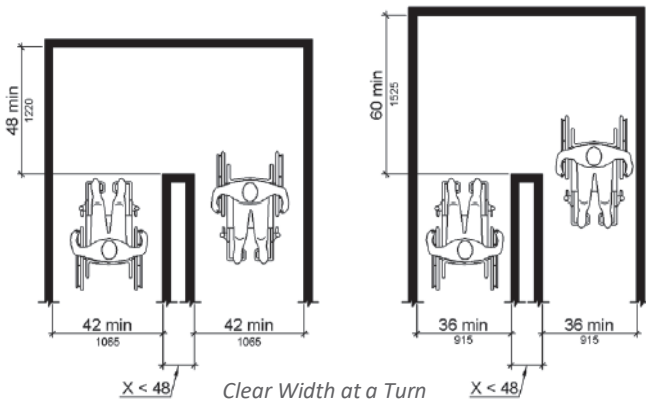

Clear Width at a Turn

Passing Spaces

Accessible routes with less than 60" clear width will provide passing spaces less than 200 feet apart. Those will be at least 60" x 60" or an intersection providing a T-shaped space where the base and arms of the T extend at least 48" beyond the intersection.

Ramps on Accessible Routes

- In assembly areas, aisle ramps need not comply when adjacent to inaccessible seating.
- In new construction, ramp runs will not be steeper than a 1:12 slope.

Table 405.2 Maximum Ramp Slope and Rise for Existing Sites, Buildings, and Facilities

Slope ¹	Maximum Rise
Steeper than 1:10 but not steeper than 1:8	3 inches (75 mm)
Steeper than 1:12 but not steeper than 1:10	6 inches (150 mm)

1. A slope steeper than 1:8 is prohibited.

- Steeper ramps are allowed in existing facilities when there are space limitations.
- Provide ramps with the least possible slope, and if possible, accompany ramps with stairs for those for

whom distance is more problematic than steps, like those with heart disease.

- Cross slopes of ramps, perpendicular to direction of travel, will not be steeper than 1:48.
- Level changes, other than running slope and cross slope, are not allowed on ramp runs.
- The clear width of a ramp between provided handrails will be at least 36", except within employee work areas, where clearances on circulation paths can be decreased by work area equipment if the decrease is essential to work being performed.
- The maximum rise for any ramp run shall be 30".
- Ramp runs with a rise greater than 6" need handrails. They can be omitted in employee work areas where ramps that are part of circulation paths are wide enough to permit the future installation of handrails, while still maintaining a clear width of 36".
- Ramps will have minimum 60" level landings at the top and the bottom of each run.
- The clear width of a ramp landing will be at least as wide as the widest run adjoining it.
- Ramps without level landings at changes in direction can create compound slopes that are not accessible. Circular or curved ramps continually changing direction and curvilinear ramps with small radii also compound slopes that are not accessible.
- Level landings are needed at accessible doors for use of the door. When this occurs, maneuvering clearances needed for doors can overlap required landing areas.
- Landings where ramps change directions need at least 60" x 60" of clear width.

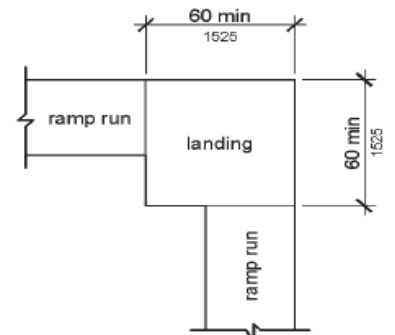
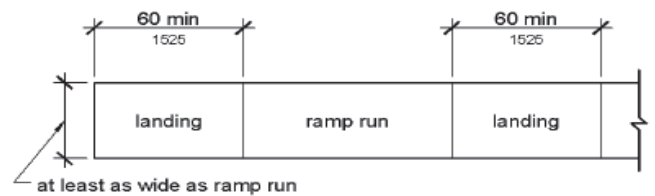

Ramp Landings

- Edge protection is needed on each side of ramp runs and landings, except for ramps not required to have handrails, ramps with flared sides with a maximum slope of 1:10, sides of landings serving an adjoining ramp run or stair and ramp landings with a maximum vertical drop-off of ½" within 10 inches horizontally of a minimum required landing.

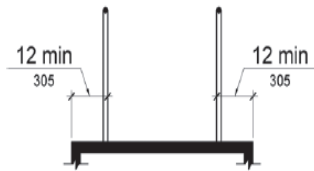

Extended Floor or Ground Surface Edge Protection

- Ground surfaces of a ramp run or landing should extend at least 12" beyond the inside face of a handrail, so wheelchair casters and crutch tips don't slip off the ramp surface.
- A curb or barrier should prevent passage of a 4" diameter sphere within 4" of the finish floor or ground surface.
- Landings subject to wet conditions shall be designed to prevent water accumulation.

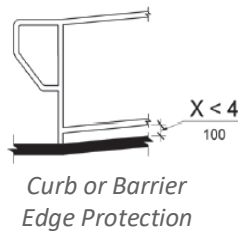

Curb or Barrier Edge Protection

Curb Ramps on Accessible Routes

- Counter slopes of adjoining gutters and surfaces adjacent to ramps may not exceed 1:20.

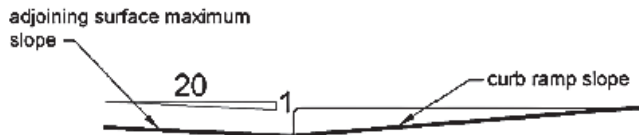

Counter Slope of Surfaces Adjacent to Curb Ramps

- Transitions from curb ramps to walks, gutters and streets shall be at the same level.
- Where provided, flares at the sides of curb ramps shall not be steeper than 1:10.

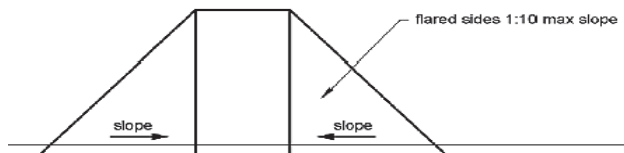

Sides of Curb Ramps

- Provide landings at the tops of curb ramps, at least 36" long and at least as wide as the curb ramp, excluding flared sides. Otherwise, use flared sides that are no steeper than 1:12.

- Curb ramps and flared sides may not project into vehicular traffic lanes, parking spaces or access aisles.

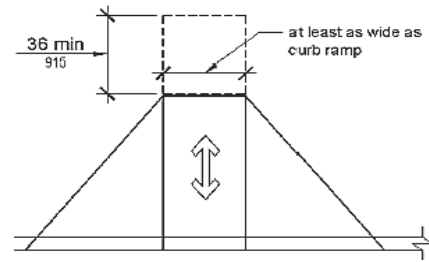

Landings at the Top of Curb

- Curb ramps and flares at marked crossings will be wholly contained within the markings.
- Diagonal or corner curb ramps, with returned curbs or other well-defined edges, will have their edges parallel to the direction of pedestrian flow.
- Bottoms of diagonal curb ramps will have a clear space of at least 48" outside active traffic lanes. Those at marked crossings will provide the 48" space within the markings.
- Diagonal curb ramps with flared sides will have a minimum 24" long curb segment located on each side of the curb ramp, and within the marked crossing.

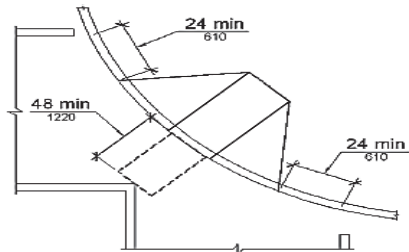

Diagonal or Corner Type Curb Ramps

- Raised islands in crossings may be cut through level with the street, or have curb ramps at each end. Each curb ramp will have a level area at least 48" x 36" wide at the top where crossing occurs. Each level area will be oriented so the 48" length aligns with the running slope of its curb ramp. The level areas and the accessible route can overlap.

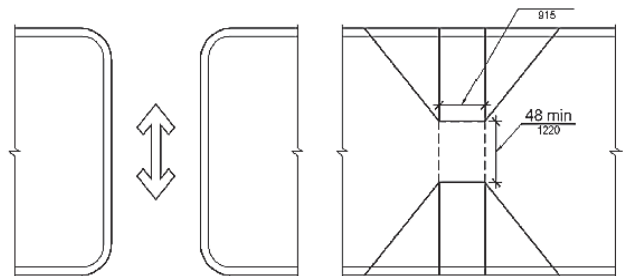

(a) cut through at island (b) curb ramp at island

Islands in Crossings

Stairways

Stairways in General on Accessible Routes

- In correctional facilities, stairs not in public use areas need not comply.
- Stairs between levels, otherwise connected by accessible routes, need not comply. But if the stairs are altered, compliant handrails will need to be provided.
- Aisle stairs in assembly areas need not comply.
- Stairs that connect play components need not comply.
- Despite accessibility requirements, building codes may still mandate handrails on stairs.
- Open risers are not permitted.
- All steps on a stair flight will have uniform riser heights and tread depths. Risers are to be 4"-7" high and treads must be at least 11" deep.
- There will be no level changes permitted in tread surfaces steeper than a 1:48 slope.

Nosings

Characteristics of stair nosings affect how usable they are for the handicapped.

- Visual contrast on tread nosings makes treads more visible to people with low vision.
- Nosings projecting beyond risers will have their underside edge curved or beveled.
- The radius at the leading edge of a tread is limited to a maximum of $\frac{1}{2}$ ".
- Risers can slope back under treads at an angle of 30 degrees maximum from vertical.
- Nosings may extend a maximum of $1\frac{1}{2}$ " over the tread below.
- Stair treads and landings will be designed to prevent water accumulation.

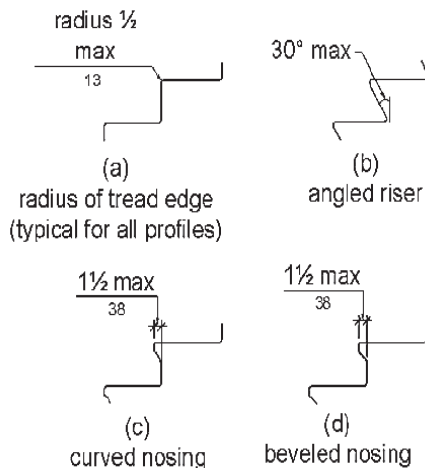

Stair Nosings

Required Handrails for Accessibility

- Handrails are required on ramps with a rise greater than 6" and on certain stairways.
- Handrails are not required on walkways with slopes less than 1:20, but if provided, must be designed for use by the handicapped.
- Handrails shall be provided on both sides of stairs and ramps, except on sides of aisle ramps in assembly areas, when one handrail is provided on either side, or within the aisle.
- Handrails will be continuous for the full length of each stair flight or ramp run. Inside handrails on switchback or dogleg stairs and ramps will be continuous between flights or runs. In assembly areas, ramp handrails need not be continuous in aisles serving seating.

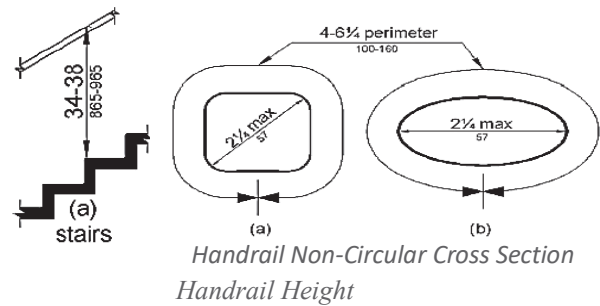

Handrail Non-Circular Cross Section
Handrail Height

- Handrails for adults are to be 34"-38" above walking surfaces, stairs and ramp surfaces.
- When children are principal users of a facility, like elementary schools, a second set of handrails 28" high can assist them and prevent accidents. If used, maintain a minimum vertical clearance of 9" between handrails to help prevent entrapment.
- Clearance between handrails and adjacent surfaces shall be at least $1\frac{1}{2}$ ".
- Tops and sides of handrails will be unobstructed and continuous, unless along walking surfaces with slopes not exceeding 1:20 and part of crash rails or bumper guards.
- Bottoms of handrails may not be obstructed for more than 20 % of their length.
- When provided, horizontal projections shall occur at least $1\frac{1}{2}$ " below the handrail bottom.
- Handrails may have a circular cross section with a diameter $1\frac{1}{4}$ "-2".
- They may have a non-circular cross section of 4"- 6 $\frac{1}{4}$ " and a maximum cross-section dimension of $2\frac{1}{4}$ ".

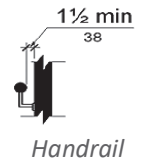

Handrail

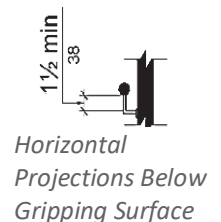

Horizontal Projections Below Gripping Surface

- Handrail surfaces, and surfaces adjacent to them, shall be free of sharp or abrasive elements and have rounded edges.
- Handrails shall not rotate within fittings.

Handrail Extensions

Handrails must extend beyond, in the same direction of stair and ramp runs, as shown.

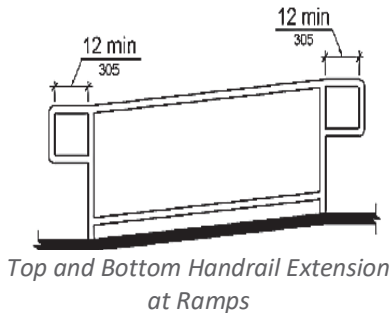

- Extensions are not required for continuous handrails at inside turns.
- Extensions are not required in aisles when handrails are interrupted to provide access to seating and permit crossovers.
- Full extensions of handrails are not required where extensions would create hazards.

- Handrails will extend at least 12" beyond landings at tops and bottoms of ramp runs and return to a wall, guard or landing surface, or be continuous to an adjacent ramp handrail.



- At the top of a stair, handrails will extend at least 12" above the landing above the first riser. Extensions shall return to a wall, guard or landing surface, or be continuous to an adjacent stair handrail.

- At the bottom of a stair flight, handrails will extend for a horizontal distance of at least one tread depth, beyond the last riser. Extensions shall return to a wall, guard or landing surface, or be continuous to an adjacent stair handrail.

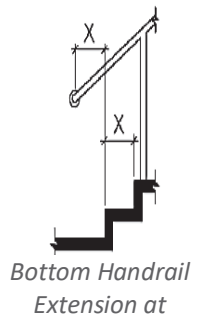

Case Study

There's nothing that will make you feel quite as ashamed as watching an older woman struggle to lift her adult son from a van and settle him in a wheelchair outside the vehicle door. All because someone saw no particular reason to honor the access aisle clearly marked between handicapped parking stalls. There was no obvious indication as to the identity of the offender. I was just glad it wasn't me.

The truth is, even codes that are used to determine the required widths of access aisles sometimes fail to take

into account that a wheelchair user must first turn and face the ramp they will use in order to ascend into a handicapped van. That equates to about four feet of width, besides the length of the ramp up into the van.



Nothing Easy About It

Ramps up into elevated entry points also tend to take up more space than expected, especially in new construction. That is unfortunate, since they are often an afterthought in the design process, even though they are a known requirement from the beginning.

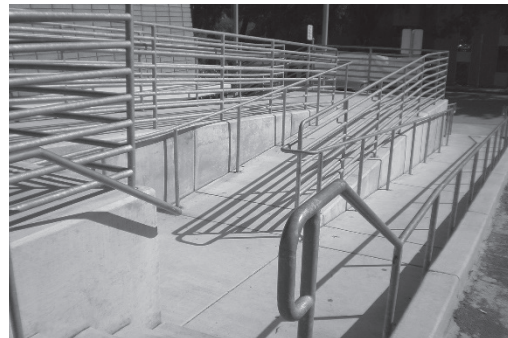

It's All Uphill From Here

The required length of ramp runs becomes especially problematic in renovation projects. It is not uncommon for many such paths of travel to occupy all available space between existing parking areas and the buildings they serve.

review questions...

6. Platform boarding edges will have a _____, extending the full length of the public use portion.
 - a. 36" high railing, except for turnstiles
 - a. 6" wide yellow line
 - a. 42" high guard railing
 - a. 24" wide detectable warning surface
7. How many entry points on accessible routes are required at soft play structures with four or more entry points?
 - a. None
 - a. One
 - a. Two
 - a. Four
8. Ground surfaces of a ramp run or landing should extend at least _____ beyond the inside face of a handrail.
 - a. 18"
 - a. 6"
 - a. 4"
 - a. 12"
9. Which of the following is NOT a required dimension for accessible ramps?
 - a. Clear width of 36" between handrails
 - a. Slopes never steeper than 1:6
 - a. Maximum 30" rise for any ramp run
 - a. Minimum 60" level landings at top and bottom of each run
10. What is the allowable range for the diameter of a handrail?
 - a. 1"-1½"
 - a. 1 ¾"-2"
 - a. 1 ½"-1 ¾"
 - a. 1¼"-2"

ENTRIES THAT ARE BAR NONE

The goal of this section will be to look at those ADA standards facilitating user entry into facilities.

General Provisions

At least one accessible means of egress is required for every accessible space, and at least two accessible means of egress are required where more than one means of egress is required.

Exit stairways and evacuation elevators qualify as accessible means of egress when provided with horizontal exits or areas of refuge. While typical elevators are not used for emergency evacuation, evacuation elevators are designed with standby power and may be used to evacuate the handicapped. Areas of refuge are fire-rated spaces on levels above or below exit discharge levels, where people unable to use stairs can call for assistance and wait for evacuation.

Doors, Doorways, and Gates

Required Accessible Passage

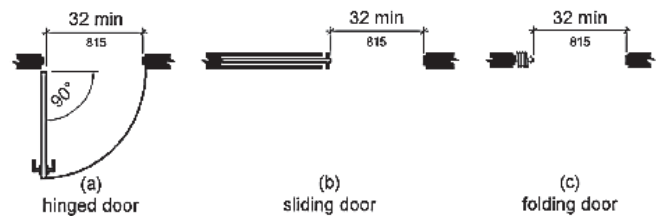

Clear Width at Doorways

- Doors, doorways and gates under the sole control of security personnel need not comply.
- Manual doors, doorways and gates intended for public user passage must be accessible.
- Revolving doors, revolving gates and turnstiles may not be part of an accessible route.
- One leaf of doorways with two leaves must comply with accessibility requirements.
- Door openings will provide a clear width of at least 32". Opening width for swinging doors is measured between door face and the stop, with the door open 90 degrees.
- Openings more than 24" deep will provide a clear opening of at least 36".
- No projections are allowed into required clear openings lower than 34" above the finished floor. Projections into opening widths 34"-80" above the finished floor may not exceed 4".
- In alterations, a projection up to 5/8" into required width is allowed on the latch side stop.

- Door closers and stops are allowed at least 78" inches above the finished floor.

Maneuvering Clearances

- Maneuvering clearances shall extend the full width of the doorway, and include the required latch side or hinge side clearance.
- Doors to hospital patient rooms need not provide clearance beyond the door's latch side.
- Swinging doors and gates will have clearances per the table and illustrations following.

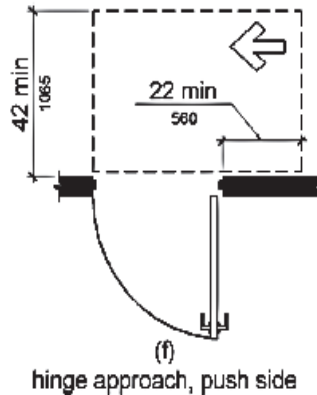
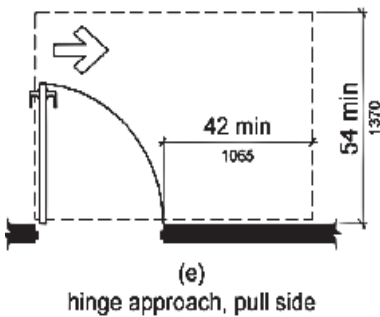
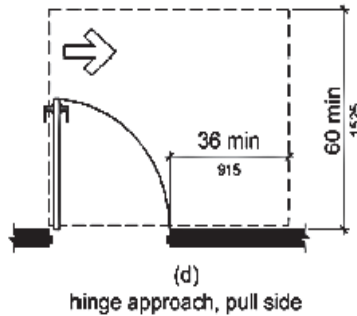
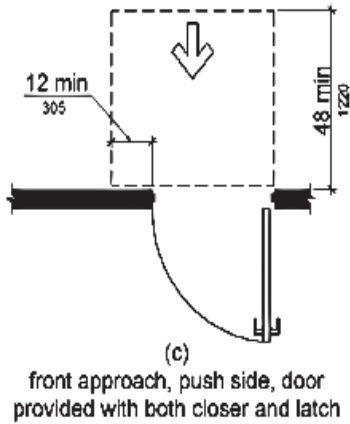
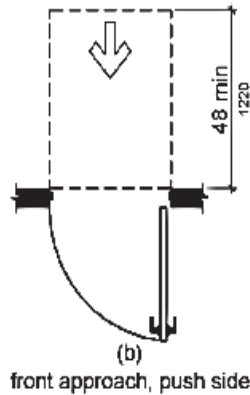
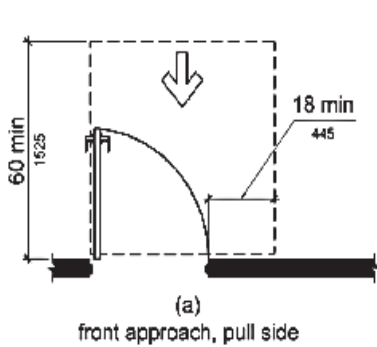

Maneuvering Clearances at Manual Swinging Doors and Gates

Table 404.2.4.1 Maneuvering Clearances at Manual Swinging Doors and Gates

Type of Use		Minimum Maneuvering Clearance	
Approach Direction	Door or Gate Side	Perpendicular to Doorway	Parallel to Doorway (beyond latch side unless noted)
From front	Pull	60 inches (1525 mm)	18 inches (455 mm)
From front	Push	48 inches (1220 mm)	0 inches (0 mm) ¹
From hinge side	Pull	60 inches (1525 mm)	36 inches (915 mm)
From hinge side	Pull	54 inches (1370 mm)	42 inches (1065 mm)
From hinge side	Push	42 inches (1065 mm) ²	22 inches (560 mm) ³
From latch side	Pull	48 inches (1220 mm) ⁴	24 inches (610 mm)
From latch side	Push	42 inches (1065 mm) ⁴	24 inches (610 mm)

1. Add 12 inches (305 mm) if closer and latch are provided.
2. Add 6 inches (150 mm) if closer and latch are provided.
3. Beyond hinge side.
4. Add 6 inches (150 mm) if closer is provided.

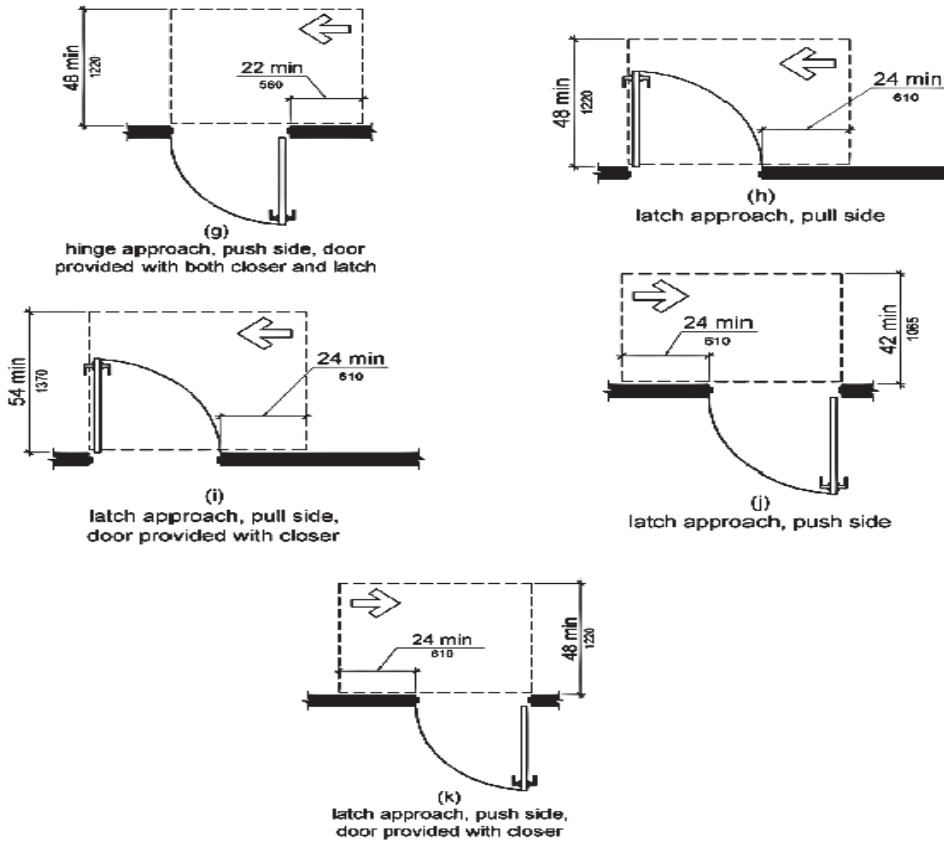

Maneuvering Clearances at Manual Swinging Doors and Gates

- Doorways less than 36" wide without doors or gates, sliding doors or folding doors are to have maneuvering clearances per the table below.

Table 404.2.4.2 Maneuvering Clearances at Doorways without Doors or Gates, Manual Sliding Doors, and Manual Folding Doors

Approach Direction	Minimum Maneuvering Clearance	
	Perpendicular to Doorway	Parallel to Doorway (beyond stop/latch side unless noted)
From Front	48 inches (1220 mm)	0 inches (0 mm)
From side ¹	42 inches (1085 mm)	0 inches (0 mm)
From pocket/hinge side	42 inches (1085 mm)	22 inches (560 mm) ²
From stop/latch side	42 inches (1085 mm)	24 inches (610 mm)

1. Doorway with no door only.
2. Beyond pocket/hinge side.

- With recessed doors and gates, clearance for forward approach will be provided when obstructions within 18" of the latch side project more than 8" beyond the door face.

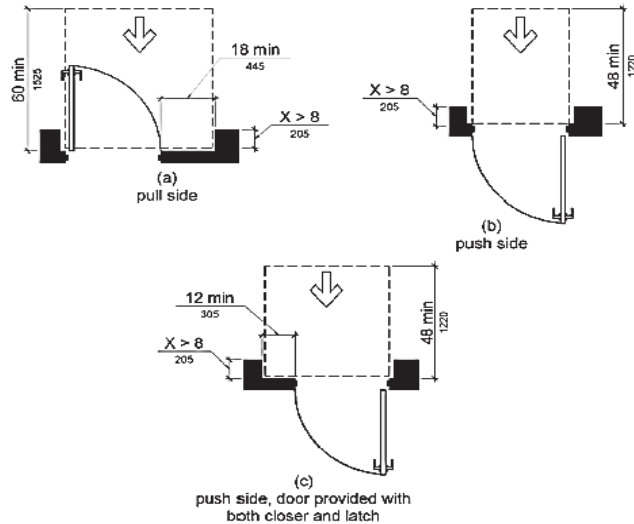

Maneuvering Clearances at Recessed Doors Gates

Floor or Ground Surface at Doors

- Changes in level are not permitted unless the slope thereof is less than 1:48.
- Thresholds complying with accessible requirements are not considered a change in level.
- Thresholds at doorways shall be a maximum of ½" high.
- Existing or altered thresholds are allowed if they are no more than ¾" high, with a beveled edge on each side, having a slope no steeper than 1:2.

Doors in Series and Gates in Series

As shown here, a distance of at least 48" should be maintained between two hinged or pivoted doors or gates

in series, besides the width of doors or gates swinging into the space.

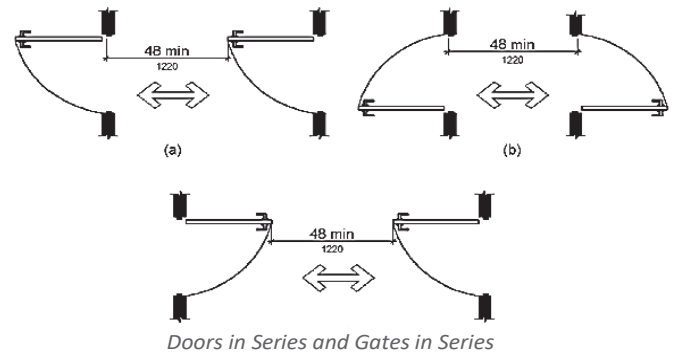

Accessible Door and Gate Hardware

This includes handles, pulls, latches, locks and other operable parts on doors and gates.

- Operable hardware shall be 34"- 48" above the finished floor or ground.
- When sliding doors are fully open, hardware will be exposed and usable from both sides.
- Existing locks may remain at existing glazed doors without stiles and overhead rolling doors or grilles designed with locks activated only at the top or bottom rail.
- Access gates in walls and fences protecting pools, spas and hot tubs can have self-latching devices at a maximum of 54" high if self-latching devices are not self-locking, but are operated by means of a key, electronic opener or integral combination lock.
- Choose door hardware that can be operated with a closed fist or loose grip.
- Doors and gates with glazing panels beside them will have at least one glazed panel located not more than 43" above the floor.

Door Closers for Accessibility

- Door and gate closers need to be adjusted so, from an open position of 90 degrees, moving the door to a position of 12 degrees from the latch will take at least 5 seconds.
- Door and gate spring hinges need to be adjusted so, from an open position of 70 degrees, moving the door to a closed position will take at least 1.5 seconds.
- Fire doors shall have their minimum opening force set by governing authorities.
- Continuous force needed applied to push or pull a door or gate (besides fire doors) will be 5 pounds for interior doors, gates and sliding or folding doors.
- This requirement does not apply to force needed to retract latch bolts or disengage other devices holding doors or gates in a closed position.

Surfaces Below Doors and Gates

Surfaces less than 10" below swinging doors and gates shall have a smooth surface on the push side extending the full width of the door or gate.

- Surface joints will create differences between adjacent planes less than 1/16" in height.
- Cavities created by added kick plates will be capped.
- Sliding doors need not comply.
- Tempered glass doors without stiles and a bottom rail tapered at 60 degrees minimum from horizontal need not meet the 10" smooth surface height requirement.
- When doors and gates are more than 10" above adjacent surfaces, they need not comply.

Accessible Automatic and Power-Assisted Doors and Gates

- Fully powered automatic doors will comply with ANSI/BHMAA156.10
- Low-energy and power-assisted doors shall comply with ANSI/BHMAA156.19
- Automatic doors must still provide a clear opening of 32" minimum in power-on and power-off mode. The minimum clear width for automatic doors will be based on the clear opening provided by all leaves in the open position.
- Maneuvering clearances at power-assisted doors and gates must still be maintained, unless automatic doors and gates remain open in the power-off condition.
- Thresholds and changes in level at automatic doors must still meet accessibility rules.
- Automatic doors and gates in series will still maintain required distances for the same.
- Clear floor space by manual controls is to be located beyond the arc of the door swing.
- Unless available manual swinging doors and gates also provide accessible egress, automatic ones without standby power will provide a clear breakout width of at least 32".
- Revolving doors, revolving gates and turnstiles shall not be part of an accessible route.

Case Study

There is a reason why turnstiles are not allowed in paths of travel.

On one of the busiest shopping days of the year, approximately a week before Christmas, holiday cheer was noticeably absent in the front entry into one of our nation's largest home improvement stores. A man who appeared to be in his late sixties helplessly sat in a wheelchair, facing a turnstile leading into the store proper. A wider swing gate

beside the turnstile could be opened for easier access, except that the latch controlling its operation was on the inside of the gate and the disabled man could not reach over the gate to open it. A customer service representative to one side of the entry would have been able to assist, but was busy serving a long line of customers returning products. So I hurried over and opened the swing gate for their customer to enter.

I understand the purpose of the one-way turnstile. It's an effective security measure to ensure customers do not wheel carts containing merchandise out an exit that cashiers are not monitoring. But—pardon my naiveté—it seemed to me that it would make more business sense to station a security officer in that location, rather than make an ever-expanding portion of the population feel as though their business is neither desired or appreciated. Consider: the population segment being barred from entry and access is the largest group with disposable income to spend on gifts for their grown children.



Sorry About That

With that freshly on my mind, I was even more surprised to find that once inside, nearly a third of the aisles between racks of shelving were too narrow to accommodate a wheelchair with a shopper in it, wanting to turn to face the merchandise.

These are peculiar business decisions that impact too many, too often.

review questions...

11. Door openings will provide a clear width of at least 32", except that a clear width of 36" is required when openings are _____.
 - a. Approached at a high rate of speed
 - b. Always locked
 - c. More than 24" deep
 - d. Less than 80" high
12. _____ is the minimum required depth for a front approach to a door from the push side.
 - a. 42"
 - b. 48"
 - c. 60"
 - d. 54"
13. Door and gate spring hinges need to be adjusted so, from an open position of _____ degrees, moving the door to a closed position will take at least _____ seconds.
 - a. 90, 5
 - b. 45, 5
 - c. 90, 1.5
 - d. 70, 1.5

NAVIGATING THROUGH THE BUILDING

The goal of this section will be to look at those ADA standards maximizing accessible pathways through facilities.

A Clear Path

Turning Spaces

When moving through a space, it's important to be able to turn around if desired.

- As used here, "changes in level" refers to surfaces with slopes exceeding 1:48. Changes in level are prohibited in clear floor and ground spaces, turning spaces and similar spaces, where people using wheelchairs and other mobility devices must park mobility aids.
- Circular turning areas will have minimum diameters of 60", with knee and toe clearance.
- A turning space can be a T-shaped space within a 60" square, with arms and a base at least 36" wide. Each arm of the T will be clear of obstructions at least 12" in each direction and the base will be clear of obstructions for at least 24". The space can include knee and toe clearance only at the end of either the base or one arm.

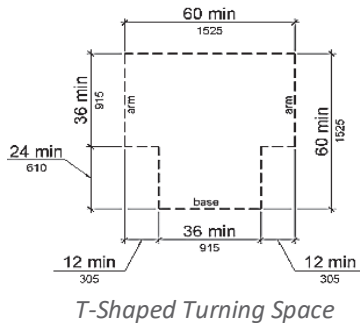

- Doors can swing into required turning spaces.

Accessible Clear Floor or Ground Space

- Clear floor or ground spaces will be at least 30" x 48" and level changes are not permitted with slopes greater than 1:48.
- Unless specified, clear floor or ground space can include knee and toe clearance.
- Unless specified, clear floor or ground space will be provided for either forward or parallel approach to an element.
- One full side of floor or ground spaces will adjoin an accessible route or another space.
- Where a clear floor or ground space is located in an alcove or space confined on three sides, additional maneuvering clearance shall be provided.
- In forward approaches, alcoves must be at least 36" wide when their depth exceeds 24".
- In parallel approaches, alcoves must be at least 60" wide when their depth exceeds 15".

- Where space beneath an element is included as part of clear floor, ground or turning space, it will be clear of any obstructions and measured relative to its usable clear space.

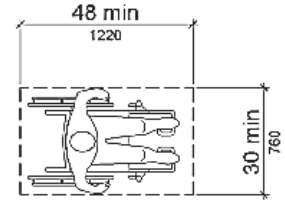

Clear Floor or Ground Space

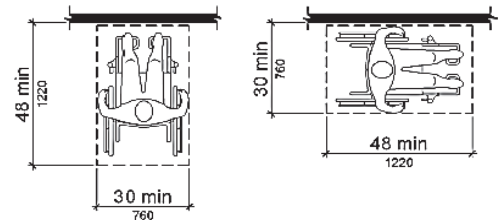

*(a) forward
(b) parallel
Position of Clear Floor or Ground Space*

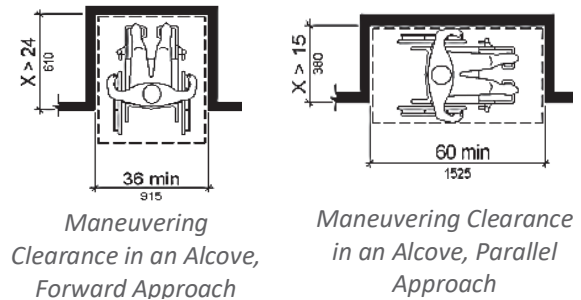

*Maneuvering Clearance in an Alcove, Forward Approach
Maneuvering Clearance in an Alcove, Parallel Approach*

Maintaining Toe and Knee Clearance

- Space between the finished surface and 9" above that surface is considered toe clearance.
- Toe clearance can extend up to 25" under an element, and when required will extend at least 17" under an element and be at least 30" wide.
- Toe clearance will be considered to only extend 6", when only 9" high.
- Space 9"-27" high is considered to be knee clearance and must extend back 25".
- When knee clearance is required as part of a clear floor space, it must be at least 11" deep where 9" high, and 8" deep where 27" high. Knee clearance must be at least 30" wide.
- When knee clearance varies between 9" and 27" high, its required depth can be reduced at a rate of 1" in depth for each reduction of 6" in height.

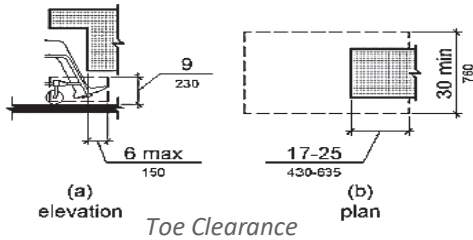

Toe Clearance

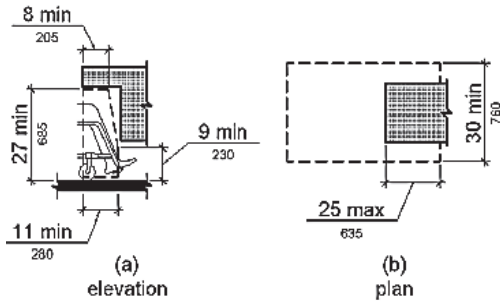

Knee Clearance

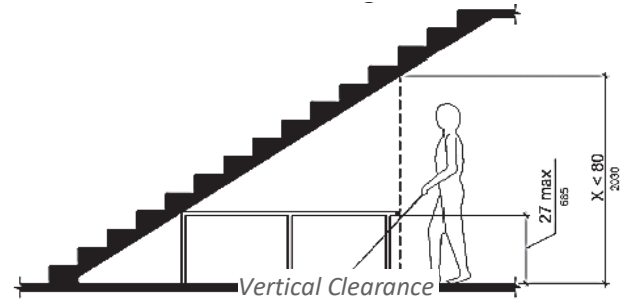

Vertical Clearance

Reach Ranges from Mobility Aids

- The following table provides guidance on forward and side reach ranges when using elements designed for use primarily by children. Accessible elements and operable parts for adults can be located outside these ranges, but must still be within reach.

Children's Reach Ranges			
Forward or Side Reach	Ages 3 and 4	Ages 5 through 8	Ages 9 through 12
High (maximum)	36 in (915 mm)	40 in (1015 mm)	44 in (1120 mm)
Low (minimum)	20 in (510 mm)	18 in (455 mm)	16 in (405 mm)

- When a forward reach is unobstructed, objects can be 15"-48" above the path.
- Where a high forward reach is over an obstruction, clear floor space will extend beneath the obstruction as far as the required reach depth. The high forward reach can be up to 48" when the maximum reach depth is 20". When the reach depth exceeds 20", the high forward reach shall be a maximum of 44" and the reach depth no more than 25".

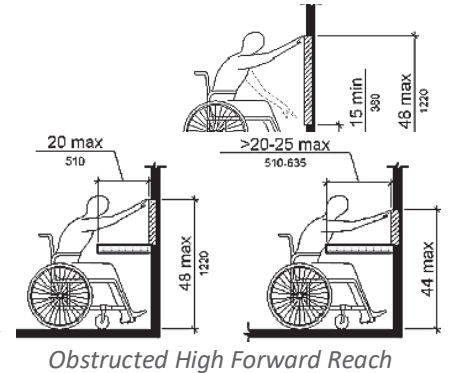

Obstructed High Forward Reach

- When a clear path allows a parallel approach to an element and an unobstructed side reach, the high side reach shall be a maximum of 48" and the low side reach shall be at least 15" above the finished floor or ground.

- An obstruction less than 10" deep is permitted between a path and the obstruction.
- Operable parts of fuel dispensers may be up 54" above the paving when dispensers are installed on existing curbs.
- Where a clear path allows a parallel approach to an element and the high side reach is over an obstruction, the obstruction shall be a maximum of 34" high and 24" deep. The high side reach can be a maximum of 48" for a reach depth of 10", but when it exceeds 10",

Limits for Protruding Objects

- Objects—even open awning and casement windows—27"-80" above finished floor can protrude only 4" into a circulation path. Handrails are allowed to protrude 4½".
- Objects on posts or pylons can overhang circulation paths up to 12", when located 27"-80" above floors. Where an object is mounted between posts or pylons more than 12" apart, the lowest edge of the object must still be 27"-80" above finished floor or ground.
- The sloping portions of handrails for stairs and ramps need not comply with this.
- Vertical clearance will be at least 80" high, or guardrails or other barriers must be provided, with the leading edge of such barrier at least 27" above the path.
- Door closers and stops can be located 78" above the finished floor or ground.
- Protruding objects cannot reduce the required clear widths for accessible routes.

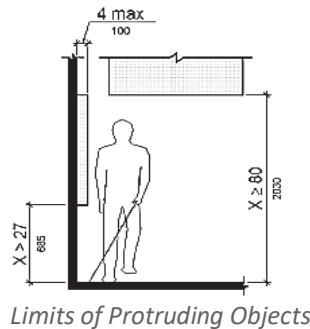

Limits of Protruding Objects

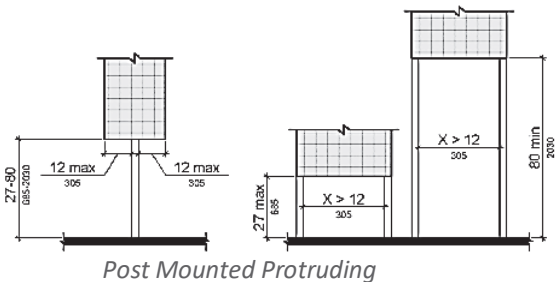

Post Mounted Protruding

the high side reach will be at most 46" for a maximum reach depth of 24".

- Tops of washing machines and dryers can be a maximum of 36" above the floor.

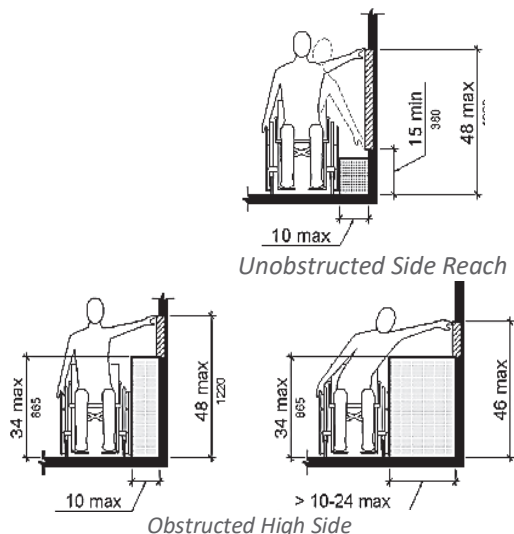

Operable Parts

A clear path should be provided to operable parts, within reach ranges specified above.

- Such parts will be operable with one hand and not require tight grasping, pinching or wrist twisting. Except for gas nozzles, force needed for operation will not exceed 5 pounds.

Vertical Conveyances

Elevators in General

Accessible elevators will be passenger elevators, with automatic operation.

- These must be in working order to serve the disabled, requiring routine maintenance and inspections. Isolated or temporary service interruptions for maintenance or repairs may occur, but failure to make prompt repairs will be a violation of accessibility laws.

Call Button Requirements

- Call buttons will be raised or flush, although existing elevators can retain recessed ones.
- Call buttons and keypads shall be located in acceptable reach ranges, measured to the centerline of the highest operable part, although existing ones may remain 54" high.
- Call buttons shall be at least 3/4" in the smallest dimension, unless already existing.
- A clear floor space, to at least 80" above the floor, needs to be provided at call controls.

- Recessed ashtrays should not be placed near elevator call buttons; otherwise persons who are blind can inadvertently contact them or their contents, reaching for the call buttons.
- Except in destination-oriented elevators with limited floor stops, the button designating the up direction shall be located above down button.

- Other than in existing elevators, call buttons will have visible signals showing when each call is registered and answered. In destination-oriented elevators, visible and audible signals should be provided indicating which elevator car to enter.

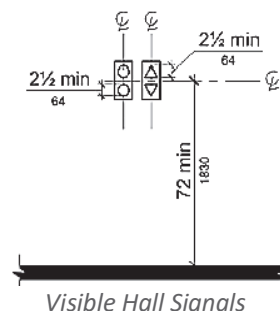

- Where keypads are provided, they shall be in a standard telephone keypad arrangement.
- A visible and audible signal will be provided at each hoistway entry, indicating which car is answering a call and the car's direction of travel.

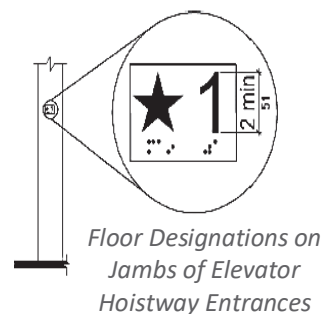

- Except in existing elevators, where in-car signals are provided, they shall be next to the hall call buttons. Visible and audible signals are not required in destination-oriented elevators when provided signals indicate the elevator car designation information.
- Except in existing elevators, visible signal fixtures will be centered 72" above the floor. Signal elements must be at least 2-1/2" high and visible from the floor adjacent to the hall call button. Destination-oriented elevators may have signals visible from hoistway entry.
- Except in existing elevators, audible signals shall sound once for the up direction and twice for the down direction, or have verbal annunciators indicating direction of travel. Audible signals will have a maximum frequency of 1500 Hz. Verbal annunciator frequencies will be in the range of 300-3000 Hz. Both types of audible signals will be at a volume of 10-80 Db above ambient noise, measured at the hall call button.
- Destination-oriented elevators need not comply with these volumes and frequencies if audible tones and announcements are the same as those given at call buttons or keypads.
- Each destination-oriented elevator will have audible and visible means for identification.
- Floor designations will be provided on both elevator

entry jambs, in tactile characters at least 2" high, and in braille. A tactile star will be provided on both jambs at the main level.

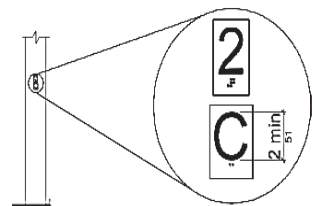

Car Designations on Jambs of Destination-Oriented Elevator Hoistway Entrances

- Elevator car dimensions and opening locations will conform to the diagrams below.

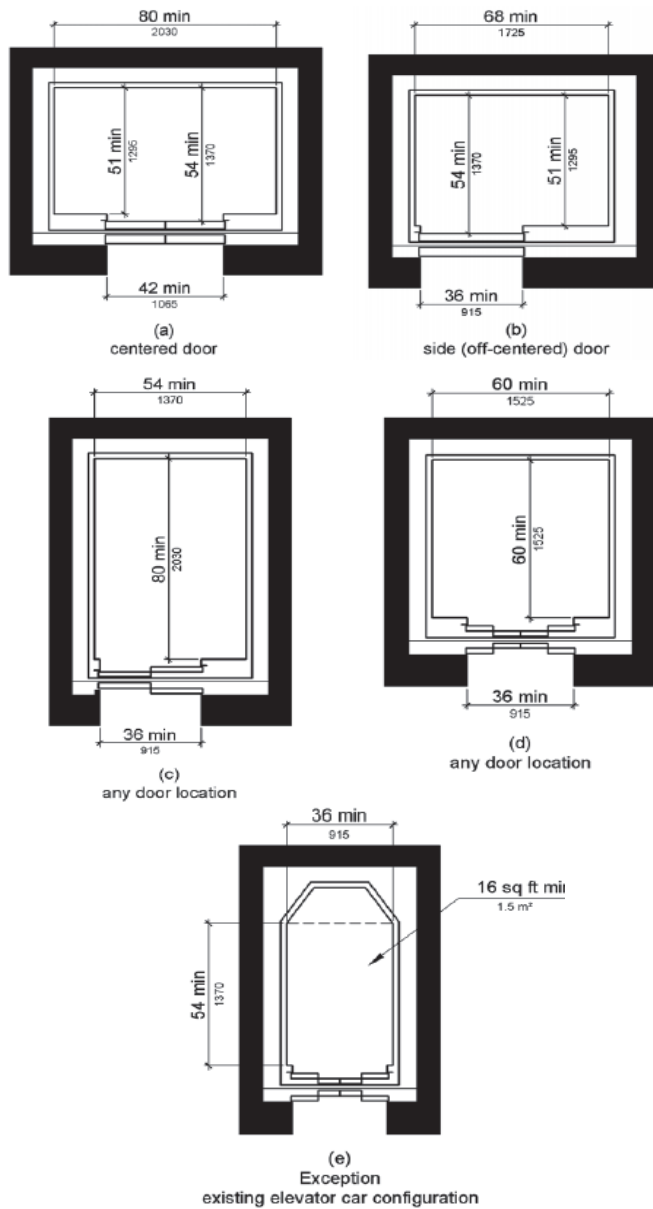

Elevator Car Dimensions

- Destination-oriented elevators will provide tactile car identification on both jambs of a hoistway, immediately below the floor designation. Car designations shall be provided in both tactile characters at least 2" high, and in braille.

Accessible Elevator Door Requirements

- Elevator doors shall be of a horizontal sliding type. Car gates are prohibited.
- Elevator hoistway and car doors will open and close automatically, except existing manually operated hoistway swing doors may remain if they are at least 32" wide and need less than 5 pounds of force to use. Car doors cannot close till the hoistway door does.
- With automatic operation, doors must have a reopening device to automatically stop and reopen a car and hoistway doors if they become obstructed by an object or person. It will activate when sensing an obstruction in the opening, 5"-29" above the floor.
- Activation will not require physical contact, though contact may occur before reversal.
- Door reopening devices will remain effective for at least 20 seconds.
- Elevator doors will remain fully open in response to a car call for at least 3 seconds.

Elevator Car Requirements

- Existing elevator cars with a clear floor area of at least 16 SF, an inside clear depth of at least 54" and a clear inside width of at least 36" will be permitted.

Table 407.4.1 Elevator Car Dimensions

Door Location	Minimum Dimensions			
	Door Clear Width	Inside Car, Side to Side	Inside Car, Back Wall to Front Return	Inside Car, Back Wall to Inside Face of Door
Centered	42 inches (1065 mm)	80 inches (2030 mm)	51 inches (1295 mm)	54 inches (1370 mm)
Side (off-centered)	36 inches (915 mm) ¹	68 inches (1725 mm)	51 inches (1295 mm)	54 inches (1370 mm)
Any	36 inches (915 mm) ¹	54 inches (1370 mm)	80 inches (2030 mm)	80 inches (2030 mm)
Any	36 inches (915 mm) ¹	60 inches (1525 mm) ²	60 inches (1525 mm) ²	60 inches (1525 mm) ²

1. A tolerance of minus 5/8 inch (16 mm) is permitted.

2. Other car configurations that provide a turning space complying with 304 with the door closed shall be permitted.







- Elevator car floors will be stable, firm, and slip resistant.
- Maximum clearance between a car platform and any hoistway landing edge will be 1/4".
- Each car will have a self-leveling feature to automatically bring and maintain the car at floor landings within a tolerance of 1/2", under rated loading to zero loading conditions.
- Light at car controls, platform, threshold and car landing will be at least 5 foot candles.

Elevator Car Controls

Other than existing controls in existing elevators, elevator car controls will be easily operable with one hand and accessible.

- Controls shall be located within specified reach ranges unless they serve more than 16 openings and have a parallel approach. Then floor buttons can be up to 54" above the floor. In existing elevators with a parallel approach, buttons can also be up to 54" high.
- Call buttons shall be raised or flush, though existing elevators can retain recessed ones.
- Buttons shall be at least 3/4" in their smallest dimension, arranged with numbers in ascending order; if in two columns, they shall read from left to right.
- Car control keypads shall be in a standard telephone keypad arrangement.
- Emergency controls, including emergency alarms, will be grouped at the bottom of the panel. Emergency control buttons shall have centerlines at least 35" above the floor.
- Control buttons shall be identified by tactile characters, with raised character and braille designations immediately left of the control button they designate. If there is no space to do so on an existing control panel, markings should be as close the control as possible.
- Control buttons for emergency stops, alarms, door open, door close, main entry floor and phones, shall be identified with tactile symbols as in the table below.

Table 407.4.7.1.3 Elevator Control Button Identification

Control Button	Tactile Symbol	Braille Message
Emergency Stop		⠠⠠⠠ "ST"OP Three cells
Alarm		⠠⠠⠠⠠ AL"AR"M Four cells
Door Open		⠠⠠⠠ OP"EN" Three cells
Door Close		⠠⠠⠠⠠ CLOSE Five cells
Main Entry Floor		⠠⠠⠠ MA"IN" Three cells
Phone		⠠⠠⠠⠠ PH"ONE" Four cells

- Visible indicator characters will be at least 1/2" high, above the car control panel or door.
- As the car passes a floor, and when a car stops at a floor served by the elevator, the corresponding character shall illuminate.
- This will not be required of destination-oriented elevators, so long as visible indicators extinguish when the call has been answered. In these elevators, a display shall be provided in the car with visible indicators to show car destinations.
- Audible indicators will be an automatic verbal annunciator, announcing the floor at which the car is about to stop. Elevators with a rated speed of 200 feet per minute or less can use a non-verbal audible signal with a maximum frequency of 1500 Hz, which sounds as the car passes, or is about to stop, at a floor served by the elevator.
- Annunciators will be 10-80 dB above ambient noise, with a frequency of 300 -3000Hz.
- Emergency two-way communication systems will be installed in elevators, with tactile symbols and characters adjacent to them to help identify them.

Limited-Use/Limited-Application Elevators (LULAs)

- Elevator operation shall be automatic and all components will still meet requirements.
- Elevator hoistway doors shall also comply, sliding or swinging. If swinging, they must open and close automatically, and remain open for at least 20 seconds when activated.

- Floor designation buttons will have visible indicators, showing a call has been registered. Visible indicators will extinguish when the call has been answered.
- Keypads shall be identified by characters centered on the corresponding keypad button. The number five key shall have a single raised dot, 0.118"-0.120" in diameter.
- Audible and visible car position indicators will be provided in elevator cars.

- Elevator cars will provide a clear width of at least 42" and a clear depth of at least 54" with a car door having at least a 32" clear width, positioned at the car's narrow ends.
- Cars providing a clear width of 51" shall be permitted to provide a clear depth of 51" if car doors provide a clear opening of at least 36".
- Existing elevator cars can provide a clear width of at least 36", a clear depth of at least 54" and a net clear platform area of at least 15 square feet.
- Maximum clearance between a car platform and any hoistway landing edge will be 1 1/4".
- Each car will have a self-leveling feature to automatically bring and maintain the car at floor landings within a tolerance of 1/2", under rated loading to zero loading conditions.
- Light at car controls, platform, threshold and car landing will be at least 5 foot candles.

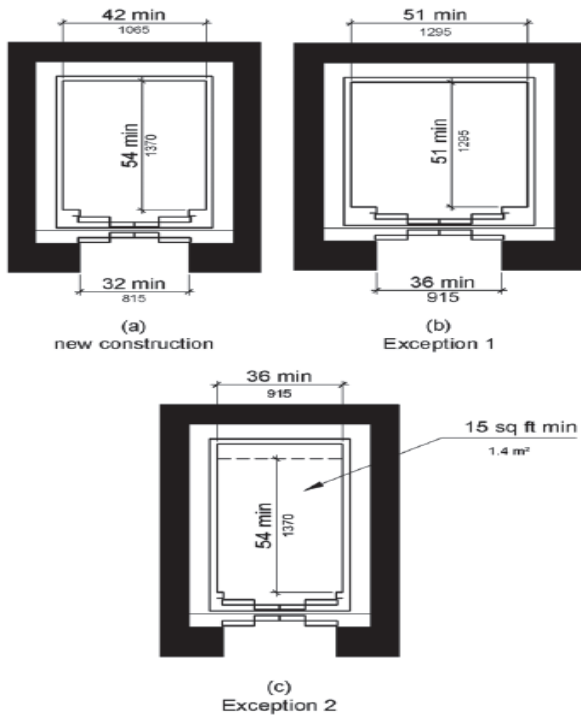

Limited-Use / Limited-Application (LULA) Elevator Car Dimensions

- Control panels will be centered on a sidewall.
- Car controls and emergency signaling devices will also comply with requirements above.

Private Residence Elevators

Private residence elevators provided within a residential dwelling unit are required to provide mobility features and comply with ASME A17.1 standards.

- They shall be classified as passenger elevators, with automatic operation.
- Call buttons will be at least 3/4" each way and comply with other standards above.
- Hoistway and car doors and gates will comply with standards above, except they need not provide clearances for approaches to the push side of swinging doors. Car and hoistway doors and gates will be automatic and remain open for at least 20 seconds. In elevator cars with two openings, hoistway doors and gates can be manual-open, self-close types.
- Elevator car doors or gates shall be at the narrow end of required clear floor spaces.
- Elevator cars shall provide a clear floor space of at least 36" x 48".
- Maximum clearance between a car platform and hoistway landing edges will be 1 1/2".
- Each car will have a self-leveling feature to automatically bring and maintain the car at floor

landings within a tolerance of 1/2", under rated loading to zero loading conditions.

- Light at car controls, platform, threshold and car landing will be at least 5 foot candles.
- Elevator car control buttons will be raised or flush, at least 3/4" each way.
- Control panels will be on a side wall, at least 12" from any adjacent wall.
- A telephone and emergency signal will be provided in cars per previous sections. If the telephone or device is in a closed compartment, the compartment door hardware will be accessible and the telephone cord will be at least 29" long.

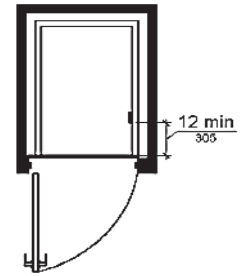

Location of Private Residence Elevator Control Panel

Platform Lifts

Platform lifts will also comply with ASME A18.1

- Platform lifts are not attendant-operated and provide unassisted entry and exit.
- Inclined stairway chairlifts and platform lifts are for short-distance vertical transportation. An accessible route requires an 80" vertical clearance; in retrofits, that clearance may not be available for people using wheelchairs and for people standing.
- Regulations require accessible features be maintained and working, requiring routine maintenance and inspections. Isolated or temporary interruptions in service may be unavoidable, but failure to promptly repair lifts is a violation.
- Requirements for flooring types and clear floor space still apply.
- Maximum clearance between the platform sill and the landing edge will be 1 1/4".
- Controls for platform lifts shall comply with previous requirements for operable parts.
- Platform lifts shall have low-energy power-operated doors or gates. Doors shall remain open for at least 20 seconds after activation.
- End doors and gates will be at least 32" wide, and side doors and gates at least 42" wide.
- Platform lifts serving only two landings, with doors or gates on opposite sides, can

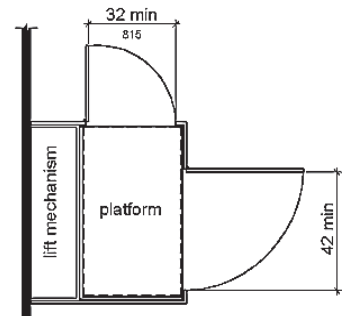

Platform Lift Doors and Gates

have self-closing manual doors or gates.

- ASME A17.1-2000 is used by local jurisdictions to regulate the design, construction, installation, operation, inspection, maintenance and repair of elevators and escalators.
- Most requirements apply to operational machinery. Some require push-button activated emergency communications in passenger elevators to connect with emergency staff, not an automated answering system. Activation buttons must be identified with the word "HELP," with a visual indication that a link to authorized personnel has been made.
- Building location, elevator car number, and a need for assistance must be provided to personnel answering the call. The need to use a handset to call is prohibited and only personnel answering the call can terminate it. Operating instructions for the communications system must be within the elevator car.
- At least two flat steps must be provided at entries and exits from escalators; they must be demarcated by yellow lines, at the most 2" wide, along back and sides of steps.
- Meeting accessibility requirements does not permit the use of inclined stairway chairlifts without platforms, because such lifts require user transfer to a seat.
- Lift enclosure walls not for entry or exit must have grab bars the full length of the wall.
- Lift types addressed in ASME A18.1 must meet requirements for capacity, load, speed, travel, operating devices and control equipment.

Case Study

The house was an old one, but it had been a childhood home and my client had inherited it. The fact that the hallways were narrow and the main floor was elevated over three feet above the surrounding grade and the floor of the detached garage behind it did nothing to daunt her determination to occupy that particular house until death or total disability made it impossible. But her double knee surgery was certainly a wrench thrown into the works.

Luckily, despite it being a farmhouse, she held no cows sacred. The living room became her temporary bedroom. A hot plate on the table became a temporary cooking station. Her husband fetched whatever she needed to minimize her need to transfer to a wheelchair. The door to their main level bathroom was temporarily removed and grab bars were installed on face mounted 2x10's. It was the fact that she was also effectively trapped in their home until she recuperated from the surgery that led her to me, looking for a pretty complete overhaul of her home.

The changes were extensive. A new addition created an enclosed connection between the garage and the home, and included a ramp to easily access the old home's main

level. Non-bearing walls on the sides of once narrow hallways became expendable, as well as the spaces on the other side of them. A renovation of the kitchen resulted in dropped work surfaces, a dropped cooktop and a lowered sink. Most importantly, she was able to easily navigate from the garage and through every space on the main level in her home.



Obstacles are Expendable Because Hallways are Made to be Traversed

That client has almost completely recovered from her surgery. But now she no longer needs to wonder whether she can continue to live in the home that has become precious to her over time.

review questions...

14. Where a clear floor or ground space is located in an alcove, or space confined on three sides, shall be provided.
 - a. A companion seat
 - b. An adjacent turning circle
 - c. Additional maneuvering clearance
 - d. Signage indicating allowed use
15. When a forward reach is unobstructed, objects can be _____ above the path.
 - a. 15"-48"
 - b. Pole mounted
 - c. 24"-36"
 - d. Pole mounted over 36"
16. 1¼" is the maximum clearance allowed between an elevator car platform and any _____.
 - a. Manual sliding gate
 - b. Hoistway landing edge
 - c. Floor indicator designations
 - d. Rails used for automatic braking
17. Which of the following is not true regarding platform lifts?
 - a. They will have low-energy power-operated doors or gates
 - b. Doors shall remain open for at least 20 seconds after activation
 - c. End doors and gates will be at least 32" wide
 - d. They will be attendant operated.

SPECIFICS FOR SPECIFIC SPACES

The goal of this section will be to look at those ADA standards establishing specific requirements for typical spaces commonly found in our facilities.

Assembly Areas

Assembly Seating Requirements

- Wheelchair spaces will be provided in assembly areas with fixed seating, in accordance with the amounts shown in the table below.

Table 221.2.1.1 Number of Wheelchair Spaces in Assembly Areas

Number of Seats	Minimum Number of Required Wheelchair Spaces
4 to 25	1
26 to 50	2
51 to 150	4
151 to 300	5
301 to 500	6
501 to 5000	6, plus 1 for each 150, or fraction thereof, between 501 through 5000
5001 and over	36, plus 1 for each 200, or fraction thereof, over 5000

- The floor or ground of wheelchair spaces will have no changes in level steeper than 1:48.
- A single wheelchair space will be at least 36" wide. Where two adjacent wheelchair spaces are provided, each space will be at least 33" wide.

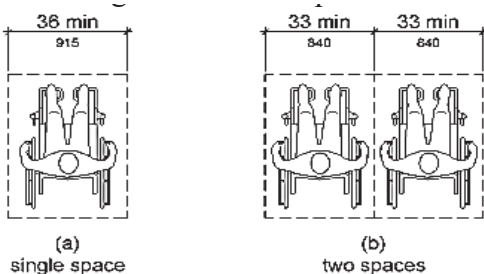

Width of Wheelchair Spaces in Assembly Areas

- When a wheelchair space can be entered from front or rear, the space shall be at least 48" deep. When it can only be entered from the side, the space shall be at least 60" deep.
- Wheelchair spaces can adjoin accessible routes but not overlap them, so access to a wheelchair space cannot be through another wheelchair space.
- Neither shall wheelchair spaces overlap the width of paths required by codes for egress.
- In each luxury box, club box and suite in arenas, stadiums and grandstands, wheelchair spaces will be provided, in not less than 20 % of all boxes provided.

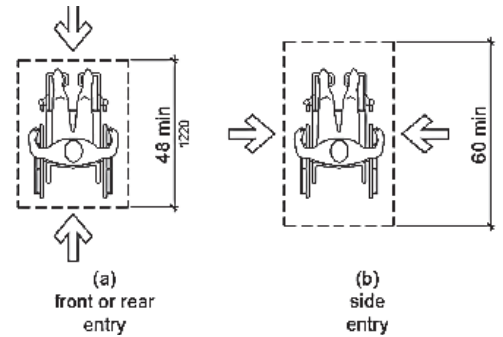

Depth of Wheelchair Spaces in Assembly Areas

- Requirements for accessible seating in "other boxes" includes box seating in facilities like performing arts auditoria, where tiered boxes are built-in. Required wheelchair spaces are calculated from total seats provided in the other boxes. The resulting wheelchair spaces must be dispersed among at least 20% of the "other boxes."
- At least one wheelchair space will be in player seating areas for sports activity. However, such spaces are not required in team seating for bowling lanes.
- Wheelchair spaces shall be an integral part of the seating plan. This means such spaces must be in footprints of seating areas, not segregated. We may not place only wheelchair spaces and companion seats outside seating defined by risers in the assembly area.

- In providing lines of sight, wheelchair spaces will provide disabled spectators with seating choices and viewing equivalent to, or better than, seating choices and viewing available to others. When a required number of wheelchair spaces has been met, further dispersion is not required. This does not apply to wheelchair spaces in player seating.

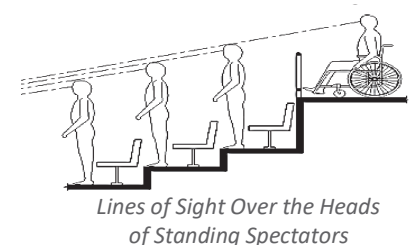
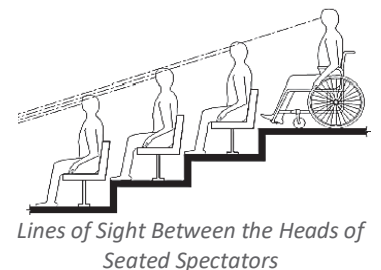
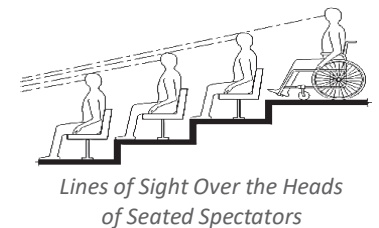

- Where spectators are expected to remain seated

during events, spectators in wheelchair spaces shall be afforded lines of sight as follows:

- Where spectators have lines of sight over spectators in the first row in front of them, spectators in wheelchairs shall be afforded lines of sight over their heads.
- Where spectators have lines of sight over shoulders and between heads of spectators in front of them, spectators in wheelchairs shall be afforded the same lines of sight.
- Where standing spectators have lines of sight over the heads of those in front of them, spectators in wheelchairs will be afforded the same lines of sight.
- Where standing spectators have lines of sight over shoulders and between heads of others in front of them, spectators in wheelchairs shall be afforded the same lines of sight.

- Individuals in wheelchairs must be provided an experience substantially equivalent to other audience members. While

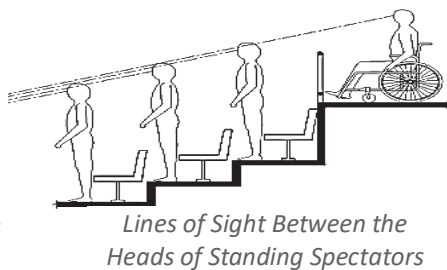

Lines of Sight Between the Heads of Standing Spectators

individuals who use wheelchairs need not be given the best seats in the house, neither may they be relegated to the worst.

- Wheelchair spaces shall be dispersed horizontally. This is not required in assembly areas with 300 or fewer seats, if they and required companion seats are located in the 2nd or 3rd quarter of total row length. Intermediate aisles shall be counted to determine total row length. If row length in the 2nd and 3rd quarters is insufficient to accommodate required spaces and companion seats, additional ones may be located in the 1st and 4th quarters of the row. In row seating, two wheelchair spaces can be located side-by-side.
- Horizontal dispersion of wheelchair spaces means placing them in an assembly facility from side-to-side, or, in an arena or stadium, around the field of play or performance area.
- Wheelchair spaces shall be dispersed vertically from a screen, performance area or playing field. Wheelchair spaces shall be located in each balcony or mezzanine on an accessible route. Vertical dispersion will not be required in assembly areas with 300 or fewer seats if wheelchair spaces offer viewing similar to the rest of the seats.
- In bleacher seating, wheelchair spaces are only required in rows at points of entry.

- When wheelchair spaces are dispersed vertically, they are placed at different locations within seating, so distance from the screen, stage or playing field is varied.
- Points of entry to bleacher seating can include; cross aisles, concourses, vomitories and entrance ramps and stairs. Vertical, center or side aisles adjoining bleacher seating that are stepped or tiered are not entry points.
- At least one companion seat will be provided with each wheelchair space.
- Other than in player areas, at least 5 % of aisle seats will have folding or retractable armrests, intended for use by those with trouble walking. They will be located closest to accessible routes, unless more aisle seats must be designated to meet the required 5%.
- Where fixed seats are not provided, lawn seating areas and exterior overflow seating areas will connect to an accessible route.

Dressing, Fitting, and Locker Rooms Requirements

- At least 5% of dressing, fitting or locker rooms provided, but at least one of each type in a cluster, will be accessible.
- Where this is infeasible, unisex rooms or one room for each sex per level will comply.
- A “cluster” is rooms adjacent to or in sight of each other, with differing room designs offering varying levels of privacy and convenience. People with disabilities should be provided rooms equally private and convenient to those for the able-bodied.
- Where coat hooks or shelves are provided, at least one of each type will be accessible.

Medical Care and Long-Term Care Facility Requirements

- Licensed facilities where patient stays exceed 24 hours will have accessible sleeping rooms.
- Toilet rooms that are part of critical or intensive care patient rooms need not comply.
- Because medical facilities reconfigure spaces to reflect changes in specialties, there is no required dispersion of accessible patient rooms. This does not mean entities are not required to provide services to the disabled. Some just locate accessible rooms near core areas, less likely to change overtime.
- All types of features and amenities should be dispersed among accessible sleeping rooms, to ensure equal access to, and a variety of choices for, all patients and residents.
- Where sleeping rooms are altered or added, requirements apply only to those sleeping rooms, until the number of accessible rooms complies with the minimum number required for new construction.

In alterations and additions, the required number is based on the total rooms altered or added, not the total number of rooms in the facility.

alterations, required dispersion is more possible if all accessible guest rooms are not provided in the same area of the facility.

- As a facility is altered over time, every effort should be made to disperse accessible sleeping rooms among different patient care areas,
- Accessibility applies to hospitals, rehabilitation, psychiatric and detoxification facilities.
- In facilities not specializing in treating conditions affecting mobility, at least 10 % but no fewer than one patient sleeping room will provide mobility features.
- In facilities specializing in treating conditions affecting mobility, 100 % of patient sleeping rooms will provide mobility features.
- Conditions affecting mobility include those requiring the assistance of a brace, cane, crutch, prosthetic device, wheelchair or powered mobility aid; arthritic, neurological or orthopedic conditions severely limiting one's ability to walk; respiratory diseases and other conditions requiring use of portable oxygen; and cardiac conditions imposing significant functional limitations.
- In licensed long-term care facilities, at least 50 %, but no fewer than one of each type of resident sleeping room will provide mobility features.

- Entrances and doorways—other than shower and sauna doors—providing passage into and within inaccessible guest rooms must still provide clear widths of at least 32". In transient lodging facilities, accessible rooms should be provided per the table below.

Table 224.2 Guest Rooms with Mobility Features

Total Number of Guest Rooms Provided	Minimum Number of Required Rooms Without Roll-in Showers	Minimum Number of Required Rooms With Roll-in Showers	Total Number of Required Rooms
1 to 25	1	0	1
26 to 50	2	0	2
51 to 75	3	1	4
76 to 100	4	1	5
101 to 150	5	2	7
151 to 200	6	2	8
201 to 300	7	3	10
301 to 400	8	4	12
401 to 500	9	4	13
501 to 1000	2 percent of total	1 percent of total	3 percent of total
1001 and over	20, plus 1 for each 100, or fraction thereof, over 1000	10, plus 1 for each 100, or fraction thereof, over 1000	30, plus 2 for each 100, or fraction thereof, over 1000

- In guest rooms with 25 beds or more, at least 5 % of the beds will offer clear floor space.
- In transient lodging facilities, guest rooms with communication features usable by the disabled will be provided per the table below.

Table 224.4 Guest Rooms with Communication Features

Total Number of Guest Rooms Provided	Minimum Number of Required Guest Rooms With Communication Features
2 to 25	2
26 to 50	4
51 to 75	7
76 to 100	9
101 to 150	12
151 to 200	14
201 to 300	17
301 to 400	20
401 to 500	22
501 to 1000	5 percent of total
1001 and over	50, plus 3 for each 100 over 1000

Accessible Transient Lodging Guest Rooms

- Certain facilities, including time shares, dormitories and town homes, may be covered by both these requirements and the Fair Housing Amendments Act.
- The Fair Housing Amendments Act requires certain residential structures with four or more dwelling units to include accessible and adaptable design features.
- Where guest rooms are altered or added, accessibility requirements apply only to those rooms until accessible guest rooms meet minimums required for new construction.
- In alterations and additions, minimum accessible guest rooms is based on the total number altered or added, not the total number of guest rooms in a facility. When accessible guest rooms are added in subsequent

- Guest rooms providing mobility features will be dispersed among different classes of rooms, providing choices of types of guest rooms, number of beds and other amenities comparable to choices provided to other guests. Where the minimum number of required accessible guest rooms is not sufficient to allow for complete dispersion, guest rooms will be dispersed by the following priority: guest room type, number of beds and amenities.
- At least one accessible guest room will also provide

required communication features.

- Factors considered as equivalent options may include: room size, bed size, cost, view, bathroom fixtures like hot tubs, smoking and non smoking and the number of rooms.

Storage Facilities

When storage is provided in accessible spaces, one of each storage type must be accessible.

- Types of storage can include closets, cabinets, shelves, clothes rods, hooks and drawers.
- At least one of each type of storage must be within specified reach ranges.
- Where lockers are provided, at least 5 % but no fewer than one of each type must be accessible. Locker types include full-size and half-size lockers, as well as those specifically designed for storage of various sports equipment.
- Self-service shelves can be located on an accessible route, but are not required to comply with reach ranges. Self-service shelves can include library, store or post office shelves.
- Self-service storage facilities shall provide individual storage spaces that are accessible, in numbers complying with the table below.

Table 225.3 Self-Service Storage Facilities

Total Spaces in Facility	Minimum Number of Spaces Required to be Accessible
1 to 200	5 percent, but no fewer than 1
201 and over	10, plus 2 percent of total number of units over 200

- Individual self-service storage spaces will be dispersed through various classes of spaces provided. Where more classes of spaces are provided than the number required to be accessible, the number of spaces need not exceed that required by the table. Accessible storage spaces need not be dispersed among buildings in a multi-building facility.

Miscellaneous Components

Dining Surfaces and Work Surfaces

No accessibility requirements exist for work surfaces used only by employees. However, other regulations entitle employees to “reasonable accommodations.” This means employers may need to procure stations like desks, laboratory and work benches, fume hoods, reception counters, teller windows, study carrels, commercial kitchen counters and conference tables, to accommodate disabled employees on an “as needed” basis. Work

surfaces that are flexible, and permit installation at variable heights and clearances, work well.

- Where work surfaces are provided for non-employees, at least 5 % will be accessible.
- Where dining surfaces are provided, at least 5 % of dining spaces will be accessible.
- Accessible dining and work surfaces required to be accessible will be dispersed throughout the facility.
- Check-out aisles, sales counters, service counters, food service lines, queues and waiting lines will be accessible. Where the selling space has less than 5000 SF, only one accessible check-out aisle will be required.
- When check-out aisles are altered, at least one aisle serving each function will comply, until the number of compliant check-out aisles meets those required in the table below.

Table 227.2 Check-Out Aisles

Number of Check-Out Aisles of Each Function	Minimum Number of Check-Out Aisles of Each Function Required to Comply with 904.3
1 to 4	1
5 to 8	2
9 to 15	3
16 and over	3, plus 20 percent of additional aisles

- At least one of each type sales and service counter will comply, and when counters are dispersed throughout the facility, accessible counters will also be dispersed.
- Counters providing different services can include: order, pick-up, express and returns. One continuous counter may be used, but all services offered must still be accessible.
- Food service lines must comply. Where self-service shelves are provided, at least 50 % but no fewer than one of each type must comply.
- Queues and waiting lines serving counters or check-out aisles must comply.

Accessible Depositories, Vending Machines, Change Machines, Mail Boxes and Fuel Dispensers

- Drive-up only depositories need not comply, including night receptacles in banks, post offices, video stores and libraries.
- When mail boxes are provided in an interior location, at least 5 % but no fewer than one of each type will be accessible. Where mail boxes are provided for each dwelling unit, accessible mail boxes must be provided for each accessible residential unit.

Windows

Where operable windows are provided in accessible spaces, at least one opening will be accessible. Windows in guest rooms providing communication features need not comply.

Two-Way Communication Systems

Where a two-way communication system is used to gain admittance to a facility or restricted areas, it will be usable by the handicapped. This applies to facilities like office buildings, courthouses and other facilities where entry can be dependent on two-way communication.

Accessible Judicial Facilities

- Where separate holding cells, including court-floor holding cells, are provided for adult male, juvenile male, adult female or juvenile female, one of each type will be accessible. If holding cells are not segregated by age or sex, only one cell must comply.
- Holding cells can serve more than one courtroom.
- Courtroom visiting areas will be accessible.
- At least 5 % but no fewer than one visitation cubicle will be accessible on both visitor and detainee sides. If counters are provided, at least one will be accessible on each side.
- If the detainee side of a visitation station does not serve cells required to be accessible, that side of the cubicle or counter need not comply.
- Where solid partitions or security glazing separates visitors from detainees, at least one of each type of cubicle or counter partition will be accessible.

Accessible Detention and Correctional Facilities

- Detention facilities can include jails, detention centers and holding cells in police stations. Correctional facilities include prisons, reformatories and correctional centers.
- General holding and housing cells shall include accessible cells, except that renovated cells need not comply unless required by the Attorney General.
- Accessible housing or holding cells should be dispersed among different levels of security, housing categories and holding classifications (e.g., male/female and adult/juvenile) to facilitate access. Many such facilities are designed so certain areas (e.g., "shift" areas) can be adapted as needed for different types of housing. Placing accessible cells in shift areas allows flexibility in meeting requirements for dispersion.
- Although cells need not be made accessible because of an alteration, each service, program or activity conducted by a public entity must be accessible to

and usable by the disabled. This must be done, unless doing so fundamentally alters the nature of a service, program or activity, or would result in undue financial and administrative burdens.

- At least 2 % but no fewer than one cell in a facility will provide mobility features.
- In cell blocks holding more than 25 beds, at least 5 % will provide clear floor space.
- At least 2 % but no fewer than one general holding or housing cell, equipped with audible emergency alarms and permanent telephones, will also provide accessible communication features.
- Where special holding or housing cells are provided, at least one cell serving each purpose will provide mobility features. Cells subject to this include those for: orientation, protective custody, administrative or disciplinary segregation, detoxification and medical isolation. Renovated cells need not comply, unless required by the Attorney General.
- Visiting areas must be accessible, as per the following:
 - At least 5 % but no fewer than one visitation cubicle will be accessible on both visitor and detainee sides. If counters are provided, at least one will be accessible on each side.
 - If the detainee side of a visitation station does not serve cells required to be accessible, that side of the cubicle or counter need not comply.
 - Where solid partitions or security glazing separates visitors from detainees, at least one of each type of cubicle or counter partition will be accessible.

Accessible Residential Facilities

- Besides requirements imposed by the ADA, residential facilities are also subject to other Federal laws, like the Fair Housing Act and amended Section 504 of the Rehabilitation Act of 1973. The Fair Housing Act requires residential structures with four or more dwelling units, privately owned or federally assisted, to meet accessible and adaptable design guidelines established by HUD (U.S. Department of Housing and urban Development). Those regulations also set minimum numbers for accessible units in multi-family projects, which must be on accessible routes and contain communication features. They also contain regulations regarding dispersal of units.
- Newly built facilities must contain minimum numbers of accessible dwelling units.
- When facilities contain 15 or less dwelling units, the minimum number of accessible units will be based on the total number of units constructed under a single contract, or developed as a whole, whether or not located on a common site.

- In multi-family facilities, at least 5 % but no fewer than one dwelling unit will be accessible and on an accessible route.
- In multi-family facilities, at least 2 % but no fewer than one dwelling unit will provide communication features for use by the disabled.
- Residential units built with public funds and offered for sale to individual buyers must also provide accessibility as required by the ADA or the Rehabilitation Act.
- When an addition increases the number of dwelling units, ADA requirements apply only to units added, until the number of units on accessible routes meets minimum numbers.
- When providing an accessible route to an altered unit is technically infeasible, a comparable dwelling unit can be built by the same entity to comply with accessibility. “Comparable” must consider the number of bedrooms; amenities in the dwelling unit; types of common spaces within the facility and proximity to community resources and services like public transportation and civic, recreational and mercantile facilities.
- When a building is vacated prior to renovations, except for pest control or asbestos removal, and contains more than 15 dwelling units, at least 5 % of renovated units will be accessible and on an accessible route. At least 2 % will contain communications devices.
- In individual dwelling units, when a bathroom or a kitchen is substantially altered along with at least one other room, altered dwelling units will be made accessible until the total number of accessible units complies with required overall numbers of dwelling units.
- “Substantial alteration” to a kitchen or bathroom can include changes to the plan configuration or replacement of cabinetry. Substantial alterations do not include normal maintenance or appliance and fixture replacement, unless those changes result in rearrangements in the plan configuration or replacement of cabinetry.
- Where facilities contain 15 or less units, accessibility requirements apply to the total number of dwelling units altered under a single contract or developed as a whole, whether or not located on a common site.
- Dwelling units providing mobility features and those with communication features must be dispersed among various types of dwelling units in the facility, to provide choices of units comparable to those available to others. Where multi-story dwellings are one type of unit provided, one-story dwelling units can be substituted for multi-story units if equivalent spaces and amenities are provided in the one-story dwelling unit.
- Accessible routes will be provided in dwelling units with mobility features, but not to unfinished attics or basements. At least one route will connect all spaces and elements in the residential dwelling unit, but not pass through bathrooms, closets, or similar spaces.
- All rooms served by an accessible route will contain a turning space for wheelchairs, except in exterior spaces less than 30” in depth or width.
- Where a kitchen is provided, it will comply with mobility requirements.
- At least one bathroom in an accessible unit will be suitable for the disabled. At least one of each type of fixture will comply. Toilet and bathing fixtures for this must be located in the same bathing area, so their use does not require travel between parts of the dwelling unit.
- Omitting vanity counter space in accessible dwelling units does not allow equal access or enjoyment of the unit, if comparable units have vanity counter tops close to the lavatory.
- Where a building fire alarm system is provided, it will activate a unit’s system.
- Where alarm appliances are provided inside a dwelling unit as part of the building fire alarm system, they shall comply with requirements for use by the disabled.
- Dwelling unit smoke detection systems shall also comply with NFPA 72 (1999 or 2002).
- All visible alarms inside a dwelling unit will activate when the building fire alarm in their portion of the building activates, as well as being activated upon smoke detection.
- The same visible alarm appliances can be used to provide notification of residential dwelling unit smoke detection and building fire alarm activation. Such alarm appliances may not be used for any other purpose inside the dwelling unit.
- Communication features shall be provided at a unit’s primary entry. A hard-wired doorbell will be provided, with a button or switch outside the entry. Use of the doorbell will initiate an audible tone and visible signal inside the unit. Where visible doorbell signals are in sleeping areas, they will have controls to deactivate the signal.
- A way to visually identify visitors without opening doors will be provided and allow for at least a 180 degree range of view. Peepholes with prisms clarify an image and offer a wide-angle view of a hallway or exterior for those standing or using wheelchairs. Such peepholes can be placed at standard height and permit views several feet from the door.
- Systems permitting voice communication between a visitor and a unit occupant need to be usable by the disabled, including interfacing with a TTY.

Guest Rooms

In accessible guest rooms, living and dining areas will be accessible, as will exterior spaces, including patios, terraces and balconies that serve the living areas.

- Turning space will be provided within the guest room.
- A clear floor space for a parallel approach will be provided on each side of a bed, unless a single clear space for a parallel approach is provided between two beds. Then a clear floor space will not be required on both sides.
- At least one bathroom provided with a guest room will be accessible. At least one water closet, lavatory and bathtub or shower will comply. In addition, roll-in showers will be accessible. Compliant fixtures can be located in more than one toilet or bathing area if travel between fixtures does not require travel between other parts of the guest room.
- If vanity counter space is provided in non-accessible toilet rooms, comparable vanity space, in size and proximity to the lavatory, will be provided in accessible toilet rooms.
- Kitchens and kitchenettes in guest rooms must be accessible.
- In guest rooms requiring accessible communication features, use equipment compatible with adaptive equipment for the hearing impaired. Provide telephone interface jacks usable with both digital and analog signals. If an audio headphone jack is provided on a speaker phone, a cutoff switch can be included so inserting the jack cuts off the speaker. If a handset is used, external speakers can be turned off when the handset is taken off the cradle. For headset or external amplification system compatibility, a standard subminiature jack installed in the telephone provides the most flexibility.
- Provided emergency warning systems must comply with accessibility guidelines.
- Visible notification devices will alert room occupants of incoming telephone calls, a door knock or bell, but will not be connected to and use visible alarm signal appliances. Telephones shall have volume controls and be served by an electrical outlet located within 48" of the telephone, to facilitate using a TTY.

Accessible Kitchens and Kitchenettes

- Where a pass-through kitchen is provided, clearances will comply with this illustration, except for spaces with no cooktop or conventional range.
- Clearances are measured from the furthest projecting face of all opposing base cabinets, counter tops, appliances or walls, excluding hardware.
- In pass through kitchens with two entries, clearance

between opposing work areas or walls will be at least 40".

- In U-shaped kitchens closed on three contiguous sides, clearance between opposing work areas or walls within the kitchen will be at least 60".

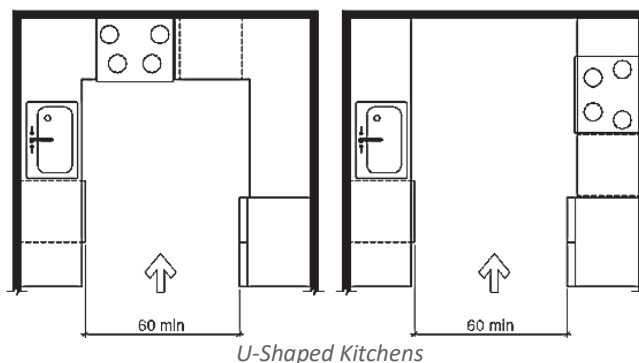
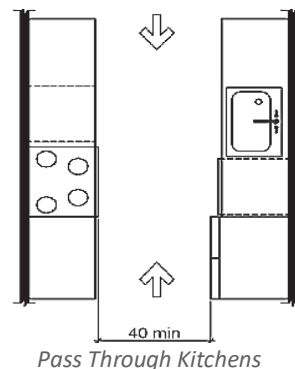

- In accessible dwelling units, at least one 30" wide section of counter will provide a work surface no more than 34" high, with knee space below. An adjustable counter that can vary between 29"-36" high will also be permitted.
- A clear floor space positioned for a forward approach will be provided, centered on that kitchen work surface and providing knee and toe clearance.
- A parallel approach will be permitted to a kitchen sink in a space where a cooktop or range is not provided, and to wet bars.
- Cabinetry is permitted under that work surface if it can be removed without replacing the work surface, flooring extends under the cabinet and walls behind it are finished.
- There will be no sharp or abrasive surfaces under work surface counters.
- An accessible sink will also be provided. In dwelling unit kitchens, sinks that are adjustable to heights of 29"-36" will be permitted, where rough-in plumbing allows supply and drain pipe connections for sinks mounted 29" high.
- Faucet controls will be accessible and metering faucets will stay open for 10 seconds.

- Exposed water supply and drain pipes under sinks must be insulated or otherwise configured to protect against contact, and contain no sharp or abrasive surfaces.
- Kitchen appliances designed to accommodate those with disabilities will be included.
- A clear floor or ground space will be at each kitchen appliance, with overlap permitted.
- Appliance controls will accommodate those with disabilities, except that bottom-hinged appliance doors, when in the open position, need not comply.
- There will be clear floor or ground space adjacent to the dishwasher. When in the open position, its door will not obstruct clear floor space for the dishwasher or the sink.
- Where a forward approach to a range or cooktop is provided, clear floor space will provide knee and toe clearance. Where knee and toe space is provided, the underside of the range or cooktop will be insulated or otherwise configured to prevent burns, abrasions or electrical shock. Control locations will not require users to reach across burners.
- Ovens will be designed for use by the handicapped, with controls on front panels, side-hinged door ovens having a work surface positioned adjacent to the latch side of the door, and bottom-hinged door ovens having a work surface adjacent to one side of the door.
- Combination refrigerators and freezers will have 50 % of freezer space at the most 54" above the floor. Floor space will allow a parallel approach to the appliance with the center of that space offset 24" maximum from the centerline of the appliance.

Accessible Saunas and Steam Rooms

- When saunas or steam rooms are clustered at a single location, no more than 5 % of them, but at least one of each type in each cluster, will need to be accessible.
- A turning space will be provided in saunas and steam rooms. Where seating is provided, at least one bench will be accessible. If removable, it can block required spaces.
- Doors may not swing into a required clear floor space.

Accessible Dressing, Fitting, and Locker Rooms

- Partitions and doors should be designed so people using accessible dressing and fitting rooms have privacy equal to that provided to other users.
- Accessible dressing rooms should have bench seats installed 17"-19" high.
- Turning space will be provided within the dressing

room, and doors will not swing into the room, unless clear floor space is provided beyond the arc of the door swing.

- Coat hooks will be located in a reach range and shelves will be a maximum of 40"-48" above the finished floor.

Patient Rooms in Medical Care and Long-Term Care Facilities

- Turning space will be provided within each accessible room.
- A clear floor space shall be on each side of the bed, positioned for parallel approach.
- Toilet and bathing rooms provided as part of an accessible sleeping room will also be accessible. At least one water closet, lavatory and bathtub or shower will comply.

Accessible Holding and Housing Cells

- Turning space must be provided within accessible cells.
- Where benches are used, one will be at least 42" long and 20" deep, with back support.
- Clear floor space for a parallel approach will be provided on at least one side of the bed.
- Toilet or bathing facilities provided in an accessible cell will comply. At least one water closet, lavatory and bathtub or shower will be accessible.
- In accessible holding and housing cells, a separate toilet room is not required.
- Some cells are required to provide communication features.
- Where audible emergency alarm systems serve occupants of cells, visible alarms will be provided other than in areas where detainees are not allowed independent means of egress.
- Telephones, where provided, will have volume controls.

Accessible Courtrooms

- Each jury box and witness stand shall have, within its defined area, clear floorspace.
- Raised or depressed areas accessed by ramps or platform lifts will provide turning space.
- In alterations, wheelchair spaces need not be located inside raised jury boxes or witness stands, but can be located outside them when ramp or platform lift access poses a hazard.

- Judges' benches, clerks' stations, bailiffs' stations, deputy clerks' stations, court reporters' stations and litigants' and counsel stations will meet accessibility standards.

Accessible Transportation Facilities - Busses

- Bus boarding and alighting areas shall be accessible.
- At bus stops with a shelter, the bus stop pad can be located inside or outside the shelter.
- Bus stop boarding and alighting areas must provide a firm, stable surface.
- Bus stop boarding and alighting areas will provide a clear length of at least 96" measured perpendicular to the roadway edge, and a clear width of at least 60" parallel to the road.
- Bus boarding areas must be connected to streets, sidewalks or pedestrian paths.
- Parallel to the road, the slope of a bus boarding area will be the same as the roadway, as much as possible. Perpendicular to the road, the slope may not exceed 1:48.
- Bus shelters will have a clear floor space within the shelter.
- Bus route identification signs will accommodate the disabled, in letter size, contrast, etc. This does not apply to bus schedules, time tables and maps posted at a bus stop.

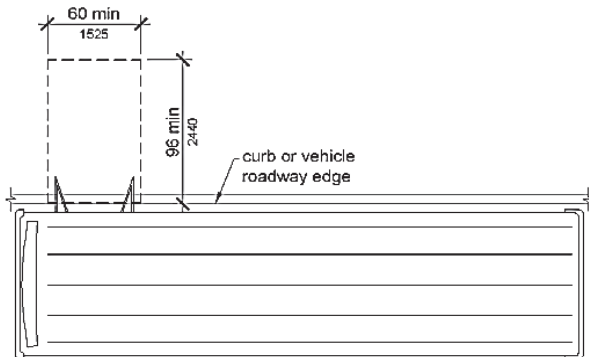

Dimensions of Bus Boarding and Alighting Areas

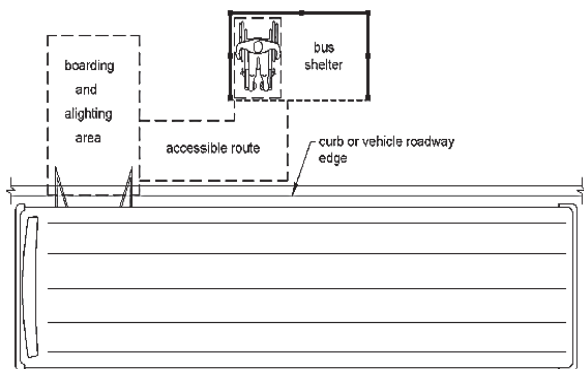

Bus Shelters

Accessible Transportation Facilities – Rail Platforms

- Rail platforms shall not exceed a slope of 1:48 in any direction, unless serving vehicles operating on existing track. Then the slope parallel to the track can equal to the existing.
- Platform boarding edges, not protected by screens or guards, must have detectable warnings along the full length of the public use area of the platform.
- Station platforms shall be positioned to coordinate with vehicles in accordance with the Accessibility Guidelines for Transportation Vehicles. These guidelines establish height and position of platforms, coordinated with floor height of the vehicles being served, to minimize vertical and horizontal gaps. The guidelines are divided by bus, van, light rail, rapid rail, commuter rail, intercity rail, and are available at www.access-board.gov.
- Preferred alignment is a high platform, level with a vehicle floor. However, low level platforms shall be at least 8" above the rail, unless vehicles will be boarded at sidewalk or street-level. Then low-level platforms can be less than 8" high.
- Rail station signs will be designed for the disabled, in letter size, contrast, braille, etc. However, compliance is not required when audible signs transmit to hand-held receivers, or are user- or proximity-actuated. With these, transmitters are placed near print signs and transmit information to an infrared receiver held by a person. By scanning an area, the person can hear signs. This means signs can be placed out of reach of braille readers, even on parapet walls and walls beyond barriers. Additionally, such signs can provide wayfinding information not efficiently conveyed on braille signs.
- Where signs identify a station at its entry, at least one sign will comply and be placed in uniform locations when practicable. Where signs identify a station with no defined entry, at least one sign will be placed in a central location.
- Lists of stations, routes and destinations served by the station, located on boarding areas, platforms or mezzanines, will be designed for the disabled, in terms of letter size, contrast, braille, etc. Route maps are not required to comply.
- At least one tactile sign identifying a station will be on each platform or boarding area. These signs should, where practical, be placed in uniform locations within the system. If space is limited, letters can be reduced to 3" high. Station identity should be clearly visible and within sight lines of standing and sitting passengers inside both sides of the vehicle, when the vehicle is stopped or stopping and another vehicle is not obstructing it.
- Where public address systems convey audible information to the public, the same or equivalent information shall be provided in a visual format.

- Faces of clocks provided for public use will be uncluttered with clearly visible elements. Hands, numbers and digits will contrast with backgrounds, light-on-dark or dark-on-light.
- Where provided, escalators will comply with accessibility requirements and have a clear width of at least 32." Existing escalators in key stations shall not be required to comply.
- Where a circulation path to boarding platforms crosses tracks, it will comply with rules for accessible routes. Openings for wheel flanges shall be permitted to be up to 2½" wide.



Case Study

One of the latest projects I completed involves a renovation of all living units in a multi-story apartment house—all 300 units, to be precise—not one of which is handicapped accessible, nor are they liable to be when this extensive renovation is complete. This is not for lack of interest, but more for lack of opportunity.

The principle problem lies in an absolute inability to get residents to any living units on the second floor or higher. There is no parking available contiguous to the building, so every resident must cross traffic lanes to approach the building. Access to the building requires climbing two steps in one direction or the other from the building entries to get to the elevators. Those existing elevators are not compliant with the ADA. And even if residents could cross traffic, get to the level of the elevators, and gain access to hallways serving the units, nothing inside those units is accessible. Making them so would require completely gutting and renovating the units.

The specific unit spaces are all non-compliant, and none more so than the bathrooms. It is rare to find, in the entire building, a hallway leading to the bathrooms that is wider than 36"; the majority is closer to 34" wide. Doorways into bathrooms are typically either 28" or 26" wide. Most are small rooms at the end of short vanities, containing tubs and water closets in a space roughly 57" x 58". Short of making most units into one room studio apartments, these will not be retrofitted for handicapped use.



Seriously Inaccessible Bathroom

The truth is, if you are disabled, this apartment building is simply not for you.

The good news is that ingenuity and a desire to really even out the access to enjoyment of life is making things possible that years ago would have been hard to imagine. A couple examples of this are shown below, to illustrate the possibilities of what can be done in specific spaces.



Just a Swingin



Gardening Once Again

review questions...

18. A wheelchair space entered from the front shall be at least _____ deep. When it can only be entered from the side, the space shall be at least _____ deep.
 - a. 48", 72"
 - b. 36", 48"
 - c. 42", 60"
 - d. 48", 60"
19. In licensed long-term care facilities ,at least _____ % but no fewer than one of each type of resident sleeping room will provide mobility features.
 - a. 50
 - b. 35
 - c. 25
 - d. 75
20. In pass through kitchens with two entries, clearance between opposing work areas or walls will be at least _____ ".
 - a. 42
 - b. 40
 - c. 38
 - d. 48
21. Guidelines establishing height and position of platforms, coordinated with floor height of the vehicles being served, are called _____.
 - a. Leveling the Accessibility Playing Field
 - b. Vehicular Access Rules
 - c. Accessibility Guidelines for Transportation Vehicles
 - d. Establishing Commuter Access (ECA)

USABLE EQUIPMENT AND HARDWARE

The goal of this section will be to look at those ADA standards establishing guidelines allowing easier use of the equipment and hardware commonly found in our facilities.

Areas with Plumbing

Accessible Drinking Fountains

- In detention or correctional facilities, drinking fountains serving inaccessible holding or housing cells need not comply.
- At least two drinking fountains will be provided. One will comply with requirements for wheelchairs, with clear floor space approaching it, knee and toe clearance, spout outlets no more than 36" above the floor, with a spout 15" from the vertical support and 5" from the front edge, providing a water flow at least 4" high. This allows a cup to be filled.
- The other fountain will serve those standing, with a spout outlet 38"- 43" above the floor.
- A parallel approach is permitted at units for children's use, where the spout is 30" at the most above the floor, and a maximum of 3½" from the front edge of the unit.
- When a single drinking fountain offers features serving all groups, it can do so.

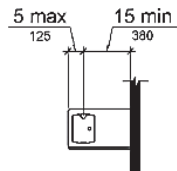

*Drinking Fountain
Spout Location*

Accessible Kitchens, Kitchenettes and Sinks

- Where sinks are provided, at least 5 % but no fewer than one of each type provided in accessible spaces must comply. However, mop or service sinks need not comply.

Accessible Toilet Facilities and Bathing Facilities

- When in facilities with stories not connected by an accessible route, toilet and bathing facilities will be provided on a story connected by an accessible route and entrance.
- Turning space shall be provided within toilet and bathing rooms.
- Required clear floor spaces, clearance at fixtures and turning spaces may overlap.
- Doors will not swing into clear floor space or clearances required for fixtures, but they can swing into required turning spaces.
- Where a room is for individual use and clear floor space is provided in the room beyond the arc of the

door swing, doors can swing into clear floor space or fixture clearances.

- When a door swing is reversed, it must still meet all requirements. The new swing cannot reduce accessible route widths or violate other building codes.
- In alterations where compliance is technically infeasible, existing toilet or bathing rooms need not be altered if a complying unisex toilet is provided in the same area.
- Where exceptions for alterations to qualified historic buildings are permitted, at least one toilet room for each sex will comply, or one unisex toilet room will comply.
- Where multiple single use portable toilet or bathing units are clustered together, at least 5% of those units at each cluster must comply.
- Unisex toilet rooms are allowed in alterations when technical infeasibility can be demonstrated. Such rooms benefit people with opposite sex personal care assistants, so it is advisable to install them, in addition to other accessible toilet rooms, in new facilities.
- A "cluster" is a group of toilet rooms, usually within sight of, or adjacent to, one another.
- Unisex toilet rooms will contain one lavatory, two water closets without urinals, or one water closet and a urinal. Unisex toilet and bathing room doors will have privacy latches.
- If water closets, urinals and sinks are provided, at least one of each must be accessible.

Accessible Lavatories

- Required accessible lavatories cannot be located in a toilet compartment.
- Knee clearance of at least 24" above the floor is allowed at sinks used primarily by children 6 -12 years, where a rim or counter surface is at most 31" above the floor.
- A parallel approach is allowed to lavatories used by children 5 years and younger.
- The dip of an overflow will not be considered in determining knee and toe clearances.
- Only one bowl of a multi-bowl sink must provide knee and toe clearance.
- Sinks can be installed with the rim or counter surface a maximum of 34" above the floor.

Children's Bathrooms

The following table provides guidance in specifying water closets for children according to age groups served, and reflects differences in size, stature and reach ranges of primary user groups.

Advisory Specifications for Water Closets Serving Children Ages 3 through 12			
	Ages 3 and 4	Ages 5 through 8	Ages 9 through 12
Water Closet Centerline	12 inches (305 mm)	12 to 15 inches (305 to 380 mm)	15 to 18 inches (380 to 455 mm)
Toilet Seat Height	11 to 12 inches (280 to 305 mm)	12 to 15 inches (305 to 380 mm)	15 to 17 inches (380 to 430 mm)
Grab Bar Height	18 to 20 inches (455 to 510 mm)	20 to 25 inches (510 to 635 mm)	25 to 27 inches (635 to 685 mm)
Dispenser Height	14 inches (355 mm)	14 to 17 inches (355 to 430 mm)	17 to 19 inches (430 to 485 mm)

- A water closet in a toilet room for a single occupant, accessed only through a private office and not for public use, need not comply.
- In dwelling units, toilet seat height shall be 15"-19" above the floor.
- Flush controls can be hand operated or automatic, located on the open side of the toilet, except in ambulatory accessible compartments. If plumbing valves are directly behind toilets, valves and related plumbing can cause injury or imbalance when a person leans back. To prevent this, plumbing can be located behind walls or to one side of the toilet.

Accessible Adult Water Closets and Compartments

- Regular water closets will be positioned with a partition behind and to one side. The centerline of the toilet will be 16"-18" maximum from the side partition, except the toilet will be at least 17"-19" from the side partition in an ambulatory accessible toilet compartment. Water closets will be arranged for a left-hand or right-hand approach.

- In dwelling units, a lavatory is permitted on the rear wall at least 18" from the toilet centerline when clearance at the toilet is at least 66", measured out from the rear wall.

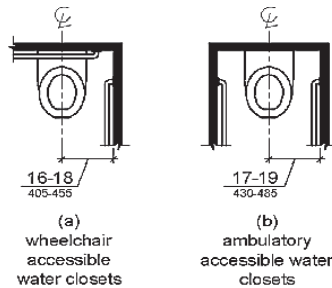

- Clearance around a water closet shall be at least 60" measured perpendicular from the side wall, and at least 56" measured out from the rear wall.

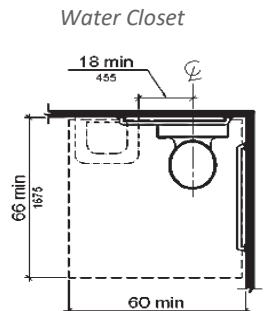

Overlap of Water Closet Clearance in Residential Dwelling Units

- Required clearance around a toilet can overlap the toilet, associated grab bars, dispensers, sanitary napkin disposal units, coat hooks, shelves, accessible routes, clear floor space, clearances required at other fixtures and the turning space. No other obstructions will be located within the required water closet clearance.

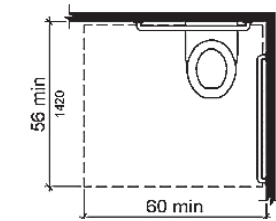

Size of Clearance at Water Closets

- When a toilet room door is placed directly in front of the toilet, the toilet cannot overlap required maneuvering clearance for the door inside the room.
- Toilet seat height will be 17"-19" above the floor, measured to the top of the seat.

Urinals

When provided, urinals shall comply with accessibility requirements.

- Stall-type urinals provide more accessibility for people of short stature.
- Urinals will be a stall or wall-hung unit with the rim a maximum 17" above the floor. They will be at least 13½" deep, measured from the face of urinal rim to the fixture back.

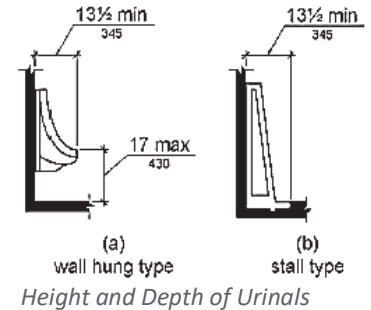

- A clear floor or ground space positioned for forward approach will be provided.
- Flush controls will be hand operated or automatic and comply with requirements.

Accessible Bathtubs

- Clearance in front of bathtubs will extend the length of the tub and be at least 30" wide. A lavatory will be permitted at the control end of the clearance.

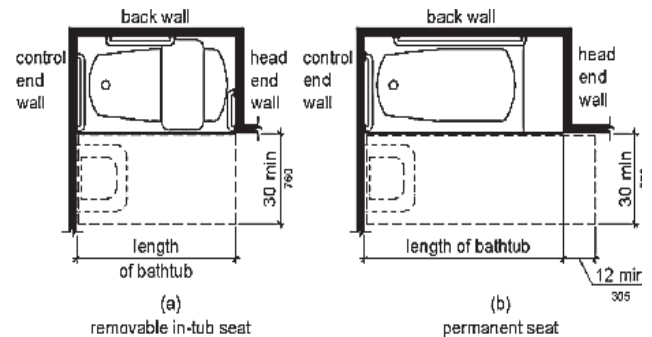

Clearance for Bathtubs

- When a permanent seat is provided at the head of the tub, clearance will extend at least 12" beyond the wall

at the head of the bathtub.

- A permanent or removable seat will be provided at the head of accessible tubs.
- Grab bars will be provided in accessible tubs with permanent seats, except for those in single occupant bathrooms accessed only through a private office and not for public use. Reinforcement must still be provided to use when installing future grab bars.

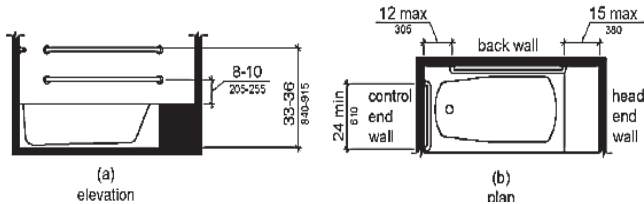

Grab Bars for Bathtubs with Permanent Seats

- In dwelling units, grab bars are not required in bathtubs if reinforcement has been provided in walls for use when installing future grab bars.
- Two grab bars will be installed on the back wall of the tub, as below. Each grab bar will be installed maximum 15" from the head wall and maximum 12" from the control wall.
- Two grab bars at least 24" long will be installed on the control end wall, at the tub edge, located at the same height as bars on the back tub wall.
- A grab bar at least 12" long will be installed on the head wall, at the tub's front edge.

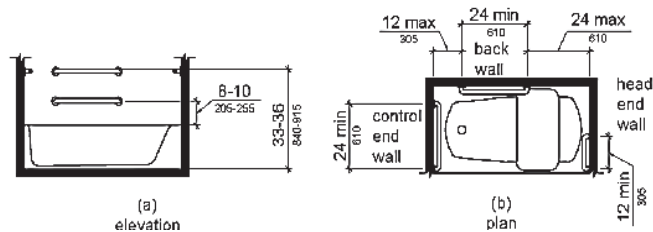

Grab Bars for Bathtubs with Removable In-Tub Seats

- Controls, other than drain stoppers, will be located on an end wall. Controls will be between the bathtub rim and grab bar, between the open side of the bathtub and the centerline of the tub width and be accessible.
- A shower spray unit with a hose at least 59" long, usable as both a fixed-position shower head and a hand-held shower, will be provided. The shower spray will have an on/off control with a non-positive shut-off and provide water under 120° F in temperature. If an adjustable-height shower head is on a vertical bar, it will not obstruct the use of grab bars.

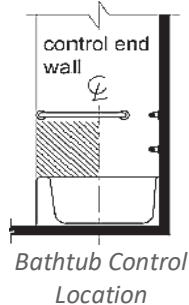

- Enclosures for tubs will not obstruct controls, faucets, shower and spray units or obstruct transfer from wheelchairs onto bathtub seats or into bathtubs. Enclosures on bathtubs will not have tracks installed on the rim of the open tub face.

Accessible Shower Compartments

- Showers that are 60" wide with no curb provide additional maneuvering space.

- Transfer type showers will have clear inside dimensions of at least 36" x 36", measured at center points of opposing sides, and at least a 36" wide minimum entry to the shower. Clearance of at least 36" wide x 48" long, measured from a control wall, will be provided.

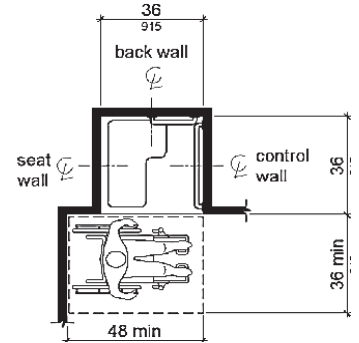

Transfer Type Shower Compartment Size and Clearance

- Standard roll-in showers will be at least 30" wide x 60" deep clear inside, measured at center points of opposing sides, with at least a 60" entry.

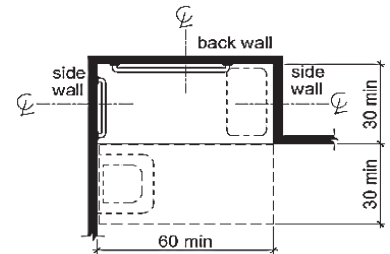

Standard Roll-In Type Shower Compartment Size and Clearance

- A minimum clearance of at least 30" wide x 60" long will be provided adjacent to the open face of the shower. A lavatory can be on one 30" wide minimum side of that clearance, if it is not on the side adjacent to controls or the shower seat.

- Alternate roll-in showers will have inside clear dimensions of at least 36" wide x 60" deep, measured at center points of opposing sides, with at least a 36" wide entry.

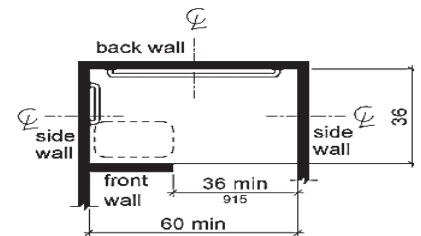

Alternate Roll-In Type Shower Compartment Size and Clearance

- Shower grab bars will be provided in accessible units. When multiple grab bars are used, horizontal grab bars will be installed at the same height above the floor.

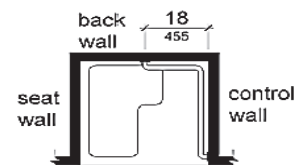

Grab Bars for Transfer Type Showers

- Grab bars will not be required in a shower in single occupant bathrooms accessed only through a private office and not for public use. Reinforcement must be provided in walls to use when installing future grab bars.

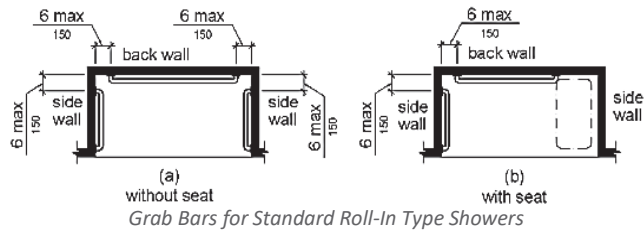

- In dwelling units, grab bars will not be required in showers if reinforcing is provided in walls to use when installing future grab bars.
- In transfer showers, grab bars will be provided across the control and back walls, to a point 18" from the control wall.
- When a seat is provided in roll-in showers, grab bars will be provided on back and side walls opposite the seat, but not above it. When a seat is not provided in roll-in showers, grab bars can be provided on three walls, a maximum of 6" from adjacent walls.

- In alternate roll-in showers, grab bars will be provided on back and side walls, farthest from the entry but not above a seat. They will be installed 6" from adjacent walls.

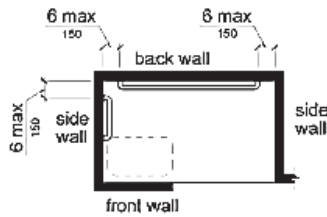

- A folding or non-folding seat will be provided in transfer showers. A folding seat can be used in roll-in showers in accessible transient rooms. In residential units, seats will not be required in transfer showers if reinforcing has been installed in walls for future use.

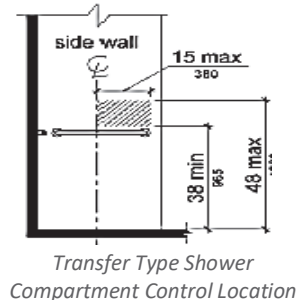

- In transfer showers, controls, faucets and shower spray units will be installed on a side wall opposite the seat, 38"-48" above the floor, on the control wall, a maximum of 15" from the center of the seat toward the shower opening.
- In standard roll-in showers, controls, faucets and shower spray units will be located above the grab bar, but no higher than 48" above the floor. When a seat is provided, controls, faucets and shower spray unit will be installed on the back wall, adjacent to the seat wall, a maximum of 27" from the seat wall.

- In standard roll-in showers without seats, the shower head and operable parts may be located on any remaining shower wall without adversely affecting accessibility.

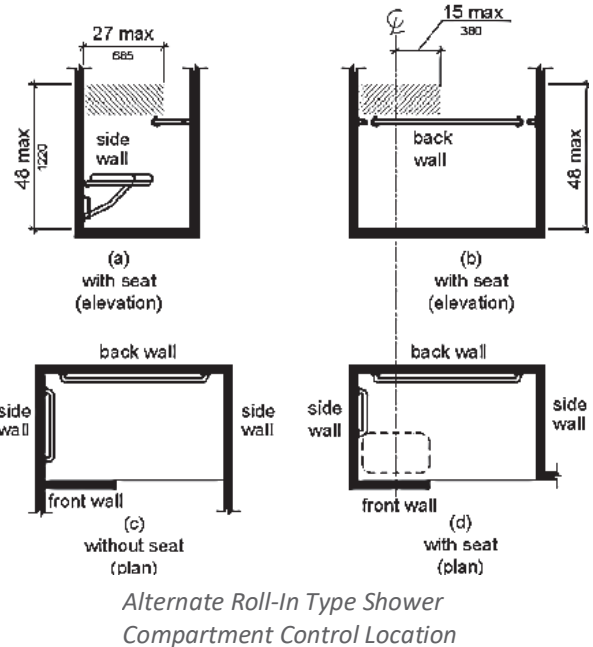
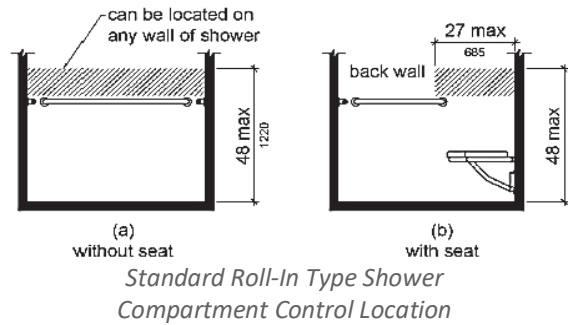

- In alternate roll-in showers, controls, faucets and shower spray units will be located above the grab bar, no higher than 48" above the floor. When a seat is provided, controls, faucets and shower spray unit will be located on the side wall adjacent to the seat, a maximum of 27" from the side wall behind the seat, or on the back wall opposite the seat, a maximum of 15" left or right of the seat center. When there is no seat, controls, faucets and shower spray unit may be installed on the side wall farthest from the shower entry.
- Shower spray units will have a hose at least 59" long, usable both as a fixed- position and a hand-held shower, delivering water under a temperature of 120° F. The unit will have an on/off control with a non-positive shut-off. If an adjustable-height shower head on a vertical bar is used, the bar will be installed to not obstruct grab bars.
- A fixed shower head, at most 48" above the floor, is allowed instead of a hand-held unit in facilities that

are not medical care facilities, long-term care facilities, transient guest rooms or residential dwelling units.

- Thresholds in roll-in showers will be a maximum of ½" high. In transfer showers, thresholds a maximum of ½" high will be beveled, rounded or vertical.
- A threshold up to 2" high will be permitted in transfer showers in existing facilities, if installing a ½" high threshold would affect the structural integrity of the floors lab.
- Enclosures for showers will not obstruct controls, faucets and shower spray units, or obstruct transfer from wheelchairs onto shower seats.

Accessible Tub and Shower Seats

- Folding and non-folding seats in bathtubs and shower compartments may be provided.
- Bathtub seats will be 17"-19" above the floor. A removable seat will be 15"-16" deep and capable of secure placement. Permanent seats at the head end of a tub will be at least 15" deep and will extend from the back wall to, or beyond, the outer edge of the tub.

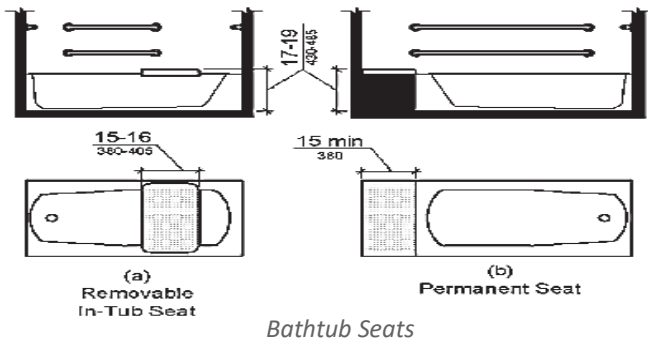

Bathtub Seats

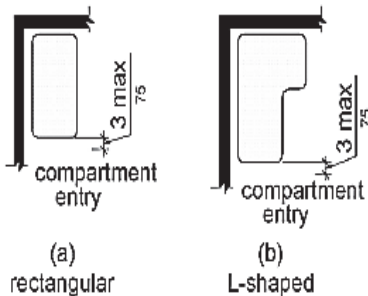

Extent of Seat

- When a seat is provided in a roll-in shower, it will be a folding type, on the side wall adjacent to controls, extending from the back wall to a point within 3" of the shower entry. When a seat is provided in an alternate roll-in shower, it will be a folding type, on the front wall opposite the back wall, extending from the adjacent side wall to a point within 3" of the entry. In transfer-type showers, the seat will extend from the back wall to a point within 3" of the entry. The top of the seat will be 17"-19" above the floor.
- The rear edge of a rectangular seat will be 2½", and the

front edge 15"-16", away from seat walls. The side edge will be a maximum of 1½" from an adjacent wall.

- The rear edge of an L-shaped seat will be 2½", and the front edge 15"-16", from seat walls. The end of the "L" will be 22"-23" from the main seat wall.

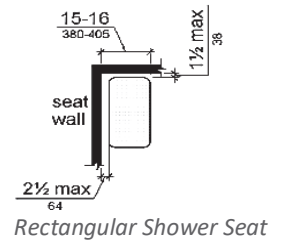

Rectangular Shower Seat

- The seat will be able to withstand a vertical or horizontal force of 250 pounds, applied at any point on the seat, fastener, mounting device or supporting structure.

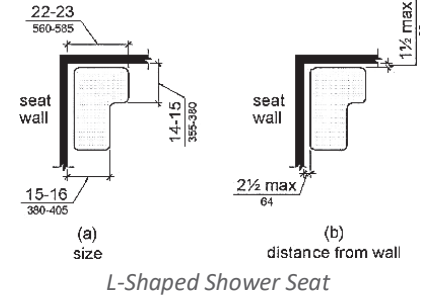

L-Shaped Shower Seat

Wheelchair Accessible Toilet Compartments

- A toilet compartment is a partitioned space in a toilet room, normally containing only one water closet. It may also contain a sink for hand-washing. Full-height partitions and doors can comprise toilet compartments when minimum required space is provided inside.
- At least one toilet compartment will be accessible, at least 60" wide and 56"-59" deep. When there are six or more toilet compartments, or six or more combined urinals and toilets, one more compartment must be at least 37" wide x 60" deep.

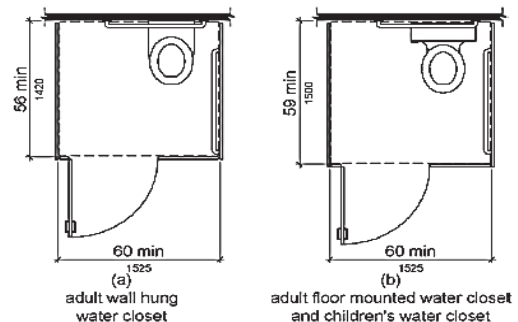

Size of Wheelchair Accessible Toilet Compartment

- Accessible compartments for children must be at least 60" wide and 59" deep.
- Maneuvering space cannot be obstructed by changing tables or other fixtures, except where overlaps are allowed.
- Convenience fixtures like changing tables must be accessible to people with disabilities.

- If an approach is to the latch side of a compartment door, clearance between the door and obstructions will be at least 42." Doors will be located in a front or side wall partition, farthest from the toilet. When in the front, door openings will be a maximum of 4" from the side wall farthest from the toilet. When in a side wall, an opening will be a maximum of 4" from the front. The self-closing door should not swing into a compartment.

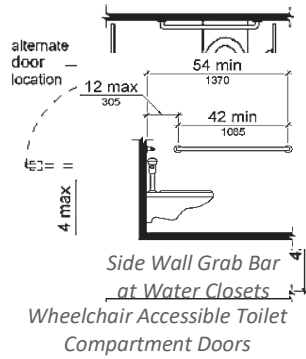

- A front partition and one side partition must provide a toe clearance of at least 9" above the floor and at least 6" beyond the compartment face of the partition.
- Compartments for child use will provide a toe clearance at least 12" above the floor, but such compartments more than 65" deep need not comply.
- Toe clearance at a front partition is not required in a compartment more than 62" deep with a wall-hung toilet, or 65" deep with a floor-mounted toilet. Toe clearance at a side partition is not required in a compartment more than 66" wide.

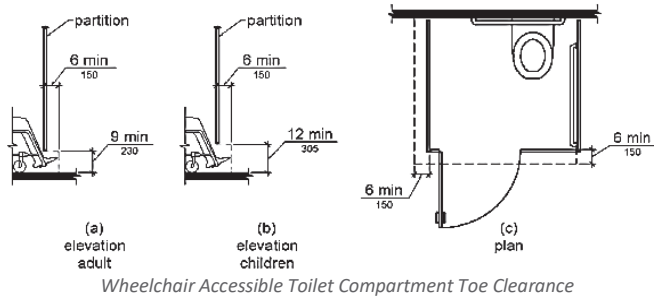

Accessible Bathroom Accessories

- Mirrors located above sinks or counters will be installed with the bottom edge a maximum of 40" above the floor. Mirrors not above sinks or counters will be installed with the bottom edge a maximum of 35" above the floor.
- When a single full-length mirror is used, the top should be at least 74" above the floor.
- When coat hooks or shelves are provided in toilet rooms without compartments, at least one of each type must comply. If provided in compartments, at least one of each type must be accessible. When they are provided in bathing facilities, one of each type must comply.
- Coat hooks will be within reach ranges and shelves located 40"- 48" above the floor.

- Toilet paper dispensers will be 7"-9" in front of a toilet, measured to the centerline of the dispenser. The dispenser outlet will be 15"-48" above the floor, not located behind grab bars, and not controlling delivery or preventing continuous paper flow.

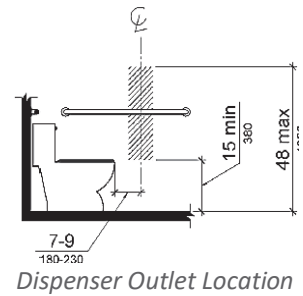

- If toilet paper dispensers are installed above a side grab bar, dispenser outlets will be a maximum 48" above the floor, and the top of the grab bar at 33"-36" above the floor.
- If soap and towel dispensers are provided, they must be within specified reach ranges and of use to a person at an accessible lavatory.

Grab Bars

- Grab bars will be provided on a side wall closest to the toilet, and on the rear wall.
- Grab bars are not required in a toilet room for a single user accessed only through a private office, but walls must be reinforced to support future installation of grab bars.
- In dwelling units, grab bars are not required, but reinforcing must be installed to support future installation of grab bars.
- In detention facilities, grab bars should not be installed in cells designed to prevent suicide.

- A side wall grab bar will be at least 42" long, located a maximum of 12" from the rear wall and extending at least 54" from the rear wall.

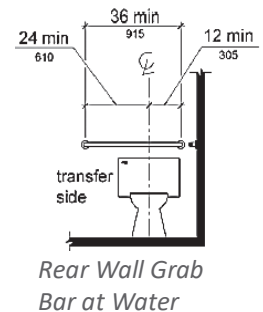

- A rear wall grab bar will be at least 36" long and extend from the centerline of the water closet, at least 12" on one side and at least 24" on the other side.

- Where rear wall space does not permit a grab bar at least 36" long, it can be at least 24" long, centered behind the water closet.

- If an enforcing authority requires flush controls in a position conflicting with rear grab bar locations, the grab bar can be split or shifted to the open side of the toilet area.

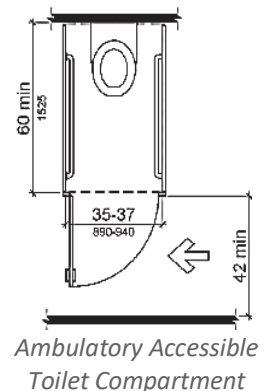

- A side-wall grab bar can be provided on both sides of an ambulatory compartment.
- Grab bars with circular cross sections will have an outside diameter of 1½"-2".
- Grab bars with non-circular cross sections will have a maximum cross-section dimension of 2" and a perimeter dimension of 4"-4.8".

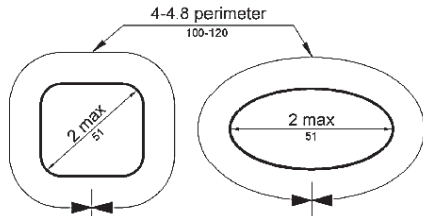

Grab Bar Non-Circular Cross Section

- Space between a wall and grab bar will be 1½". Space between grab bar and projecting objects below and at the ends will be at least 1½". Space between grab bar and projecting objects above will be at least 12". Space between grab bar and shower controls, shower fittings and other grab bars above will be at least 1½".
- Grab bars will be installed horizontally, 33"-36" above the floor, measured to the bar top. At toilets for child use, grab bars will be installed horizontally, 18"-27" above the floor.
- Grab bars and surfaces near them will be free of sharp or abrasive elements and have rounded edges.
- Grab bars can be installed in any manner providing a gripping surface at specified locations, not obstructing required clear floor space and not allowing bars to rotate.

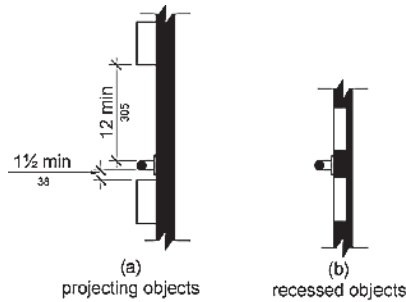

Spacing of Grab Bars

- Grab bars must withstand a vertical or horizontal force of 250 pounds, applied at any point on the bar, fastener, mounting device or structure.

Accessible Washing Machines and Clothes Dryers

- Where three or fewer washers or dryers are provided, at least one of each must comply.
- Where more than four washers and dryers are provided, at least two of each will comply.
- A clear floor or ground space for parallel approach will be provided. Required clear floor space will be centered on the appliance.
- Operable parts like doors, lint screens and soap

compartments will be in reach ranges.

- Top loading machines will have the laundry compartment door located a maximum of 36" above the floor. Front loading machines will have the bottom of the laundry compartment opening located 15"-36" above the floor.

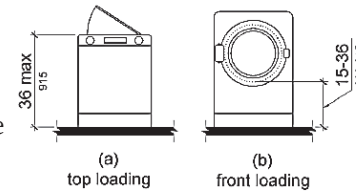

Height of Laundry Compartment Opening

review questions...

22. A shower spray unit with a hose at least 59" long, usable as both a _____ and a hand-held shower, will be provided.
 - a. Fixed-position shower head
 - b. Variable spray unit
 - c. Shower wall scrub
 - d. Shower seat cleaner
23. In transfer showers, controls, faucets and shower spray units will be installed _____.
 - a. On a side wall opposite the seat
 - b. 38"-48" above the floor
 - c. On the control wall, a maximum of 15" from the center of the seat toward the shower opening
 - d. All of the above
24. Where rear wall space does not permit a grab bar at least 36" long, it can be at least 24" long, _____.
 - a. Centered behind the water closet
 - b. Centered above the water supply
 - c. 12" to the left of a flush valve
 - d. 6" above the lid of the tank

COMMUNICATION FEATURES

The goal of this section will be to look at those ADA standards enhancing the ability of the disabled to better communicate in and around facilities.

Communication Features in General

Conflicting Guidelines

- NFPA regulations, some of which incorporate Underwriters Laboratory guidelines, specify characteristics of audible alarms, like placement and sound levels. The ADA limits the volume of an audible alarm to 110 dBA, rather than the 120 dBA permitted by NFPA 72-1999. NFPA specifies characteristics for visible alarms, like flash frequency, color, intensity, placement and synchronization. The ADA requires visual alarm appliances be permanently installed. UL guidelines also specify intensity dispersion requirements for visible alarms and NFPA requires

visible alarms to have a light source that is clear or white, with polar dispersion. The most stringent rules must be followed.

Notifications

Alarm Systems

- Fire alarm systems will have permanently installed audible and visible alarms.
- In existing facilities, visible alarms are not required unless an existing fire alarm system is upgraded or replaced, or a new fire alarm system is installed.
- Unlike audible alarms, visible alarms must be located in the space, so their signal is seen.
- The maximum allowable sound level of audible notification appliances will be no more than 110 dB, at the minimum hearing distance from the audible appliance.
- Facility alarm systems (other than fire alarm systems), like those used for tornado warnings and other emergencies, are not required to comply. But every effort should be made to ensure such alarm signals can be differentiated from fire alarms, and that people who need emergency notification are adequately safeguarded.
- Alarms in public use areas and common use areas will comply.
- Where employee work areas have audible alarm coverage, wiring systems must be designed so compliant visible alarms can be integrated into the alarm system.
- Guest rooms required to be accessible shall provide alarms that also comply.
- Where provided in residential units required to be accessible, alarms will also comply.
- Fire alarm systems in medical care facilities shall be permitted to be provided in accordance with industry practice.

Signage

General Considerations

- These requirements apply to signs providing designations, labels or names for interior rooms or spaces, where the sign is not likely to change over time. Tactile text is also required for pictograms labeling or identifying a permanent room or space. Standard recognized pictograms providing information, like “no smoking,” occupant logos and the International Symbol of Accessibility are not required to have text descriptors.

- Signs providing directions or information about interior spaces include rules of conduct and occupant load. Signs providing directions include those that identify egress routes.
- Signs for means of egress will comply.
- Building directories, menus, seat and row designations in assembly areas, occupant names, building addresses and company names and logos need not comply.
- Parking facility signs need not comply with all requirements.
- Temporary signage, in place for 7 days or less, need not comply.
- In detention and correctional facilities, signs not in public areas need not comply.
- Exterior signs not located at the door to the space they serve need not comply.
- Doors at exit passageways, exit discharges and exit stairways shall be identified by tactile signs. An exit passageway is a horizontal exit component separated from interior spaces by fire-resistance-rated construction, leading to an exit discharge or public way. An exit discharge is the egress portion between the termination of an exit and a public way.
- Signs required by the International Building Code, providing instructions in areas of refuge or directions to accessible means of egress, will comply with these requirements.
- Accessible parking spaces will be identified by compliant signs. When four or fewer spaces, including accessible spaces, are provided, identification of accessible spaces is not required. When parking spaces are assigned to specific dwelling units, identification of accessible parking is not required.
- When not all entrances are accessible, those which are will be identified by the International Symbol of Accessibility. Directional signs, indicating the location of the nearest accessible entry, will be provided at entrances that do not comply.
- When not all existing elevators are accessible, elevators which are will be clearly identified with the International Symbol of Accessibility.
- When not all existing toilet rooms or bathing rooms are accessible, directional signs indicating the location of the nearest accessible toilet room will be provided. Signs on those which do comply will include the International Symbol of Accessibility. Where clustered single user toilet facilities are allowed, accessible spaces will be distinguished by the International Symbol of Accessibility, unless all toilets are accessible.
- Each assembly area required to provide assistive listening systems will provide signs informing patrons

of the available system. Signs will include the International Symbol of Access for Hearing Loss. Such signs are not required at each assembly area if signs at each ticket window inform patrons of the availability of assistive listening systems.

Table 703.5.5 Visual Character Height

Height to Finish Floor or Ground From Baseline of Character	Horizontal Viewing Distance	Minimum Character Height
40 inches (1015 mm) to less than or equal to 70 inches (1780 mm)	less than 72 inches (1830 mm)	5/8 inch (16 mm)
	72 inches (1830 mm) and greater	5/8 inch (16 mm), plus 1/8 inch (3.2 mm) per foot (305 mm) of viewing distance above 72 inches (1830 mm)
Greater than 70 inches (1780 mm) to less than or equal to 120 inches (3050 mm)	less than 180 inches (4570 mm)	2 inches (51 mm)
	180 inches (4570 mm) and greater	2 inches (51 mm), plus 1/8 inch (3.2 mm) per foot (305 mm) of viewing distance above 180 inches (4570 mm)
greater than 120 inches (3050 mm)	less than 21 feet (6400 mm)	3 inches (75 mm)
	21 feet (6400 mm) and greater	3 inches (75 mm), plus 1/8 inch (3.2 mm) per foot (305 mm) of viewing distance above 21 feet (6400 mm)

- When more than one check-out aisle is provided, accessible check-out aisles will be identified by the International Symbol of Accessibility. When check-out aisles are identified by numbers or letters, they will be located in the same location as the accessibility sign. If all check-out aisles comply, signs will not be required.
- When accessible unload areas for amusement rides also serve as accessible load areas, signs indicating their location will be provided at entries to queues and waiting lines.
- Amusement rides designed primarily for children, those controlled or operated by the rider and amusement rides without seats need not provide wheelchair spaces, transfer seats, transfer systems or meet sign requirements. The load and unload areas of these rides must, however, be on an accessible route and provide turning space.

Compliant Lettering

- Where both visual and tactile characters are required, either one sign with both character types, or two separate signs with one of each, will be provided.
- Raised characters will comply with requirements following and be duplicated in braille.
- Signs designed to be read by touch should not have sharp or abrasive edges.
- Raised characters will be at least 1/32" above their background.
- Characters will be uppercase and sans serif. They should not be italic, oblique, script, highly decorative or other unusual fonts.
- Characters will be selected from fonts where the width of the uppercase letter "O" is 55% - 110 % of the height of the uppercase letter "I."
- Character height, measured vertically from the character baseline, will be 5/8"-2", based on the height of the uppercase letter "I." When raised and visual characters provide the same information, raised character height may be as small as 1/2" high.

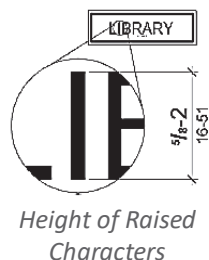

- Visual characters must be at least 40" above the finished floor, except those in elevators.
- Stroke thickness of the uppercase letter "I" will be 10 % -30 % of the character height.
- Character spacing will be measured between closest points of adjacent characters within a message, excluding word spaces. Where characters have rectangular cross sections, spacing between individual raised characters shall be 1/8" - 4 times raised character stroke widths. Where characters have other cross sections, spacing between individual characters will be 1/16" - 4 times raised character stroke widths, at the base of the cross sections, and 1/8" - 4 times raised character stroke widths, at the top of cross sections. Characters will be separated from raised borders and decorative elements by at least 3/8".
- Spacing between baselines of separate lines will be 135 % -170 % of character height.
- Characters shall contrast with their background with either light characters on a dark background or dark characters on a light background. This greatly increases legibility for those with persons with low vision.
- Additional factors affecting legibility include shadows cast by lighting, surface glare, the uniformity of text and its background colors and textures.

Compliant Braille

- Braille dots will have a domed or rounded shape and dimensions will comply with the table and illustration below. Uppercase letters will only be used before the first word of sentences, proper nouns and names, individual alphabet letters, initials and acronyms.
- Braille will be positioned below corresponding text. If text is multi-lined, braille will be placed below

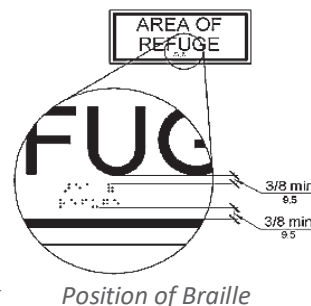

the entire text. It will be separated at least 3/8" from any other tactile characters and from raised borders and decorative elements.

- Braille provided on elevator car controls will be separated at least 3/16" and will be located either directly below, or adjacent to, corresponding raised characters or symbols.

Table 703.3.1 Braille Dimensions

Measurement Range	Minimum in Inches Maximum in Inches
Dot base diameter	0.059 (1.5 mm) to 0.063 (1.6 mm)
Distance between two dots in the same cell ¹	0.090 (2.3 mm) to 0.100 (2.5 mm)
Distance between corresponding dots in adjacent cells ¹	0.241 (6.1 mm) to 0.300 (7.6 mm)
Dot height	0.025 (0.6 mm) to 0.037 (0.9 mm)
Distance between corresponding dots from one cell directly below ¹	0.395 (10 mm) to 0.400 (10.2 mm)

1. Measured center to center.

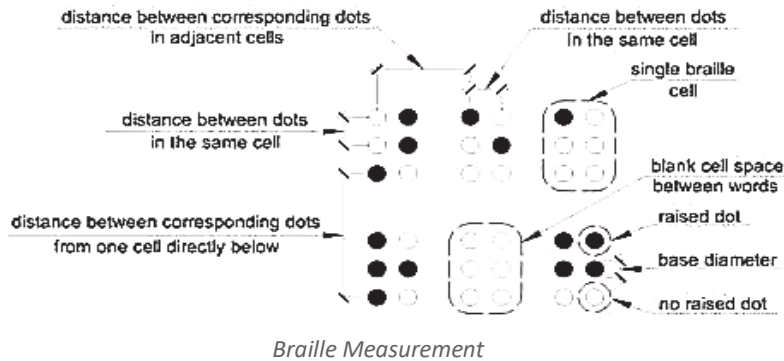

When a tactile sign is provided at double doors with two active leaves, it will be on the right of the right hand door. Where there is no wall space beside doors, it will be located on an adjacent wall.

- Signs containing tactile characters will be located so a clear floor space of 18" x 18", centered on the words, is provided beyond the arc of any door swing between the closed position and a 45° open position.

- Tactile signs can be on push sides of doors with closers and without hold-open devices.

Pictograms

Pictograms shall comply with requirements below.

- Pictograms will be at least 6" high, and contain no characters or braille in their field.
- Pictograms will have a non-glare finish and either a light pictogram on a dark field or a dark pictogram on a light field. Text descriptors will be directly below the pictogram.

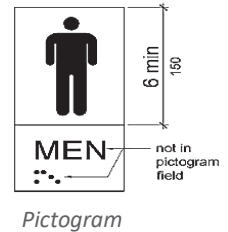

- Additional factors affecting legibility include shadows cast by lighting sources, surface glare, and the uniformity of the text and background colors and textures.

- An International Symbol of Accessibility shall comply with the figure to the right.



International Symbol of Accessibility

Compliant Tactile Signs

- Tactile characters on signs will be located at 48"-60" above the floor or ground, measured from the baselines of the lowest characters and the highest characters.
- Tactile characters for elevator car controls need not comply.

- When a tactile sign is provided at a door, it will be on the latch side. When a tactile sign is at double doors with one active leaf, it will be on the inactive leaf.

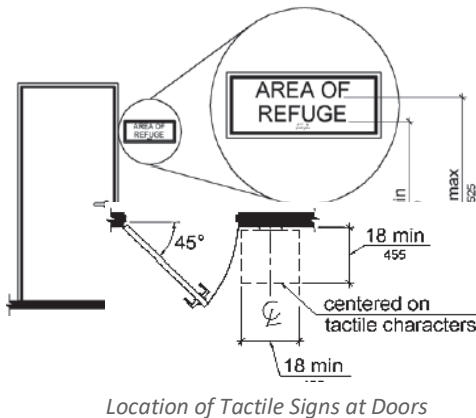

- An International Symbol of TTY shall comply with the figure to the right.
- Telephones with a volume control shall be identified by a pictogram of a telephone handset with radiating sound waves on a square field, like that shown to the lower-right.
- Assistive listening systems shall be identified by the International Symbol of Access for Hearing Loss shown below.



International Symbol of TTY



Volume Control Telephone



International Symbol of Access for Hearing Loss

Accessible Telephones

- When coin-operated public pay telephones, coinless public pay telephones, public closed-circuit telephones, public courtesy phones or other types of public telephones are provided, at least one of each provided type will be accessible.
- A clear space will be provided at phones, unobstructed by bases, enclosures or seats.
- Where public telephones are provided, wheelchair accessible telephones will be provided per the table below. Drive-up only public telephones need not comply.

Table 217.2 Wheelchair Accessible Telephones

Number of Telephones Provided on a Floor, Level, or Exterior Site	Minimum Number of Required Wheelchair Accessible Telephones
1 or more single units	1 per floor, level, and exterior site
1 bank	1 per floor, level, and exterior site
2 or more banks	1 per bank

- TTYs for handicapped use will also be provided, permanently affixed or adjacent to the telephone enclosure. Where an acoustic coupler is used, telephone cords will be sufficiently long to allow connection of the TTY and the telephone.
- Separate requirements are based on how many public pay telephones are provided in a floor, a building or on a site. Some phone systems accommodate both digital and analog transmissions for compatibility with digital and analog TTYs.
- Public pay telephones accommodating portable TTYs will be equipped with a shelf and outlet, in or adjacent to the telephone enclosure. The handset will be capable of being placed flush on the shelf. The shelf will accommodate a TTY and still have at least 6" vertical clearance above where the TTY will be placed.
- Where four or more public phones are grouped in a bank, at least one public TTY will also be provided, unless another TTY is located within 200 feet and on the same level.
- On floors where at least one public phone is provided, a public TTY will be provided.
- Where four or more public phones are provided on a private building floor or exterior site, one public TTY will also be provided on that floor or on that site.
- Where at least one public telephone is provided at a public rest stop, emergency roadside stop or service plaza, at least one public TTY will be provided.
- Where at least one public pay telephone is provided serving a hospital emergency room, recovery room or waiting room, at least one TTY will be provided at each location.

- In transportation facilities, where a public phone serves a particular facility entry, at least one public TTY will also serve that entry. In airports, where four or more public phones are located outside security areas, a concourse within security, or baggage claim areas, at least one TTY will be provided in each location.
- In detention and correctional facilities, where at least one telephone is provided for use only by detainees, inmates and security, a TTY will be provided in a secured area.
- Where there are three or more public phones, at least one will be provided with a shelf and outlet, unless it is in a detention facility where shelves and outlets are prohibited.

- TTY keypads will be at least 34" above the floor, unless seats are provided.
- A phone with a TTY beneath cannot be wheelchair accessible, because the required 34" of height for the keypad causes the highest operable part of the phone, usually the coin slot, to exceed maximum permitted side and forward reach ranges.

- Where a parallel approach is provided to a phone, the distance from the edge of phone enclosure to the face of the telephone will be a maximum of 10".
- Where a forward approach is provided to a phone, the distance from the edge of a counter in the phone enclosure to the face of the telephone will be a maximum of 20".
- Telephones will have push-button controls when such service is available.
- Telephone directories will be provided, where available.

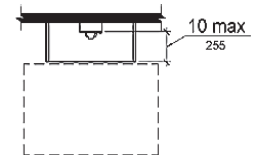

Parallel Approach to Telephone

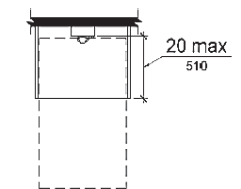

Forward Approach to Telephone

- Cords from a telephone to a handset will be at least 29" long.
- Public telephones must have volume controls and be equipped with a receiver volume control providing an adjustable gain up to 20 dB minimum, with at least one transitional step of 12 dB of gain. Provide an automatic reset.

Transportation Facilities

- New and altered stations in rapid rail, light rail, commuter rail, intercity rail, high speed rail and other fixed guideway systems will be accessible.
- Key stations and existing intercity rail stations and bus shelters will be accessible.
- In all transportation facilities, public address systems and clocks will comply.

Assistive Listening Systems

- Assistive listening systems use different modes of transmission and include hard-wired systems and three wireless types: induction loop, infrared and FM radio transmission.
- Each has different advantages and disadvantages determining which system is best for a given application. For example, FM systems may be better than infrared in open-air assemblies, since infrared signals are less effective in sunlight. An infrared system is typically a better choice than FM when confidential transmission is important, because it will be contained within a space.
- Technical standards for assistive listening systems include minimum performance levels for volume, interference and distortion.
- Selecting or specifying an effective assistive listening system for a large or complex venue requires assistance from a professional sound engineer.
- An assistive listening system will be provided in each assembly area relying on audible communication. But other than in courtrooms, assistive listening systems will not be required where audio amplification is not provided.
- Receivers will be provided for assistive listening systems in each assembly area, per the table below. At least 25 % of receivers provided, but no fewer than two, will be hearing-aid compatible. Receivers will include a 1/8" standard mono jack.
- Receivers required to be hearing-aid compatible shall interface with telecoils in hearing aids through the provision of neckloops.
- Where a building contains more than one assembly area under one management, the number of required receivers is based on the total number of seats in all areas.
- Where all seats are served by an induction loop assistive listening system, a minimum number of receivers needing to be hearing-aid compatible will not be required.

Table 219.3 Receivers for Assistive Listening Systems

Capacity of Seating in Assembly Area	Minimum Number of Required Receivers	Minimum Number of Required Receivers Required to be Hearing-aid Compatible
50 or less	2	2
51 to 200	2, plus 1 per 25 seats over 50 seats ¹	2
201 to 500	2, plus 1 per 25 seats over 50 seats ¹	1 per 4 receivers ¹
501 to 1000	20, plus 1 per 33 seats over 500 seats ¹	1 per 4 receivers ¹
1001 to 2000	35, plus 1 per 50 seats over 1000 seats ¹	1 per 4 receivers ¹
2001 and over	55 plus 1 per 100 seats over 2000 seats ¹	1 per 4 receivers ¹

1. Or fraction thereof.

Accessible Automatic Teller and Fare Machines

- Where these are provided, at least one of each type at each location will be accessible.
- Clear space will be provided, except at drive-up automatic teller and fare machines.
- If bins are provided for envelopes or waste paper, at least one of each type shall comply.
- If a bank provides interior and exterior ATMs, each is considered a separate location. Accessible ATMs, including those with speech and those within reach of wheelchair users, must provide all functions provided to other customers at that location.
- Collection devices accommodating perforated tokens allow better differentiation between tokens and common coins.
- Accessible gates and fare vending machines should be close to other accessible elements.
- Machines will be speech enabled. Operating instructions and orientation, visible transaction prompts, user input verification, error messages and all displayed information will be usable by individuals with limited vision. Speech will be delivered through a mechanism available to all users, including but not limited to a standard connector or a telephone handset. Speech shall be recorded or digitized human, or synthesized.
- People who are visually impaired, as well as people with limited reach who use wheelchairs or have short stature and cannot effectively block the ATM screen with their bodies, may prefer speech output. These users will benefit from an option to render the visible screen blank, there by affording greater personal security and privacy.
- Audible tones will be permitted instead of speech for visible output not displayed for security purposes, including asterisks representing personal identification numbers.

- Where speech synthesis is not supported, dynamic alphabetic output need not be audible.
 - If an ATM also dispenses coupons, sells theater tickets or provides copies of monthly statements, all functions must be available to customers using speech output.
 - Speech shall be capable of being repeated or interrupted, and have volume control.
 - Where receipts are provided, speech output devices will provide audible balance inquiry information, error messages and all information also on the printed receipt.
 - At least one tactilely discernible input control will be provided for each function. Key surfaces not on active areas of display screens will be raised above surrounding surfaces.
 - Numeric keys will be arranged in a 12-key ascending or descending keypad layout, with the number five key tactilely distinct from the other keys. Both orders for keys are acceptable, provided the computer-style keypad is organized similarly to the number pad located at the right on most computer keyboards, and does not resemble the line of numbers located above the computer keys.
- | | | |
|---|---|---|
| 1 | 2 | 3 |
| 4 | 5 | 6 |
| 7 | 8 | 9 |
| * | 0 | # |

7	8	9
4	5	6
1	2	3
*	0	#
- (a) 12-key ascending (b) 12-key descending
Numeric Key Layout
- Function keys will contrast visually from background surfaces. Characters and symbols on keys will contrast visually from key surfaces, either light-on-dark or dark-on-light.
 - Function key surfaces will have tactile symbols as follows: Enter or Proceed key = raised circle; Clear or Correct key = raised left arrow; Cancel key = raised letter "x;" Add Value key = raised plus sign; Decrease Value key = raised minus sign.
 - Display screens will be visible 40" above the clear floor space in front of the machine.
 - Characters displayed on screens will be in a sans serif font, at least 3/16" high, based on the uppercase letter "I." Characters will contrast with their background with either light characters on a dark background or dark characters on a light background.
 - Braille instructions for initiating a speech mode will be provided.

Accessible Two-Way Communication Systems

- Devices not requiring handsets are easier to use by people with a limited reach.

- Systems will provide both audible and visual signals, including one to visually indicate that assistance is on the way. Signs should indicate the meaning of visual signals.
- Handset cords, when provided, shall be at least 29" long.
- Communications systems between a dwelling unit and a site, building or floor entrance will be designed for accessible use.
- Common use or public use system interfaces will include the capability of supporting voice and TTY communication, with the dwelling unit interface.
- A residential unit system interface will include a telephone jack capable of supporting voice and TTY communication, with a common use or public use system interface.

review questions...

25. Temporary signage, not required to comply with disability requirements, is defined as _____.
- Mounted with removable fasteners
 - Capable of being changed electronically
 - In place for 7 days or less
 - On a location scheduled for demolition
26. Raised characters on signs will be atleast _____ above their background.
- 1/8"
 - The thickness of a dime
 - 1/32"
 - 1/4"
27. Telephones with a volume control shall be identified by a pictogram of a _____.
- Telephone handset with radiating sound waves
 - Microphone on a stand
 - Dial with graduation marks around the perimeter
 - Two lips being shushed by a finger

FINISHING WELL

The goal of this section will be to look at those ADA standards maximizing the safety of those traversing common surfaces.

Surfacing Materials

Compliant Floor or Ground Surfaces

- Floor and ground surfaces will be stable, firm and slip resistant.
- A stable surface remains unchanged by contaminants or applied force, and when they are removed, the surface returns to its original condition.

- A firm surface resists deformation by either indentations or particles on its surface.
- A slip-resistant surface provides sufficient friction to permit safe ambulation.
- Floor and ground surfaces for animal containment and sports activities need not comply.
- Carpet will be securely attached, with a firm cushion, pad, backing or no cushion or pad.
- Carpet will have a level loop, textured loop, level cut pile or level cut/uncut pile texture. Pile height will be a maximum of $\frac{1}{2}$ ". Exposed carpet edges will be fastened to floor surfaces, with trim on the entire length of the exposed edge.
- Carpets and permanently affixed mats can significantly increase the amount of force needed to propel a wheelchair over a surface. The firmer the carpeting and backing, the lower the roll resistance. Soft carpet padding increases roll resistance.

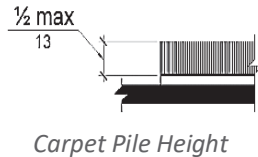

Openings

Openings in floor or ground surfaces should not allow passage of a sphere more than $\frac{1}{2}$ " in diameter. Elongated openings will be placed so their long dimension is perpendicular to the dominant direction of travel.

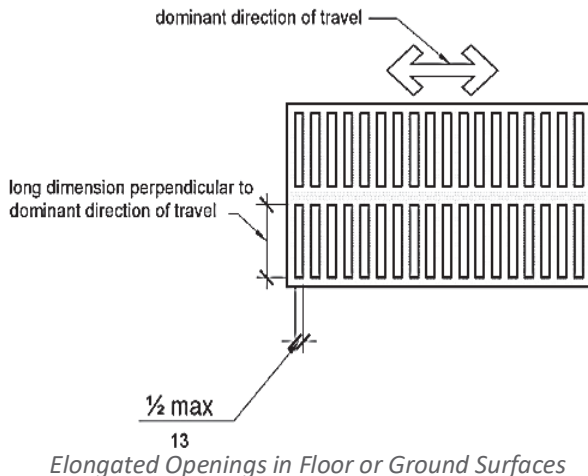

Accessible Changes in Level

- Animal containment areas and areas of sports activity need not comply.
- Vertical changes in level up to $\frac{1}{4}$ " high are permitted.
- Changes in level $\frac{1}{4}$ "- $\frac{1}{2}$ " will include a bevel with a slope not steeper than 1:2. In no case will a combined

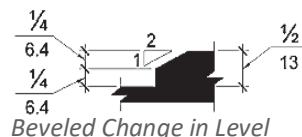
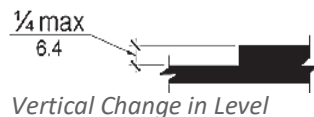

change in level exceed $\frac{1}{2}$ ". Those higher are considered to be ramps and turning space will be required, with no change in level steeper than 1:48 permitted.

Furniture

Compliant Dining Surfaces and Work Surfaces

- Dining surfaces and work surfaces for use by children need not comply.
- Dining surfaces may include bars, tables, lunch counters and booths.
- Work surfaces can include writing surfaces, study carrels, student laboratory stations, baby changing and other personal grooming stations, coupon counters and possibly employee work stations.
- Clear floor space for a forward approach, and knee and toe spaces, are needed.
- Tops of dining and work surfaces for adults will be 28"-34" above the finished floor.
- Tops of dining and work surfaces for children will be 26"-30" above the finished floor, with clear ground space for a forward approach and a knee clearance of at least 24".

Compliant Benches

- Clear space will be provided at the end of a bench, parallel to the short axis of the seat.
- Benches will have seats at least 42" long and 20"-24" deep.
- Benches will provide back support or be affixed to a wall. Back support will be at least 42" long and extend from a maximum 2" above the seat to a point at least 18" above the seat, with back support a maximum of 2 $\frac{1}{2}$ " horizontally from the rear edge of the seat.
- Grab bars on a wall by the seat can help with transferring to the bench, but may not be attached to the seat back or obstruct transfer to the bench.
- Tops of bench seats will be 17"-19" above the finish floor or ground.
- Benches will support a vertical or horizontal force of 250 pounds, applied at any point on the seat, fastener, mounting device or supporting structure.
- Where installed in wet locations, seats will be slip resistant and not accumulate water.

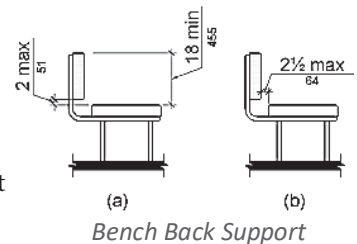

Compliant Check-Out Aisles and Sales and Service Counters

- All portions of accessible counters will be located adjacent to a walking surface.
- If a cash register is provided at a sales or service counter, the accessible portion should be near the register, so wheelchair users are visible to sales personnel and the reach for a disabled person is minimized. Where provided, check writing surfaces will be accessible.
- Counter surface height at a check-out aisle will be at most 38" above the floor. Counter edge protection will be maximum of 2" above the counter surface on the aisle side.

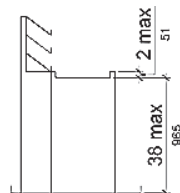

- Accessible portions of sales and service counters will be the same depth as other portions.

- In alterations, if meeting requirements will result in reducing the number of existing counters, the counter may have a compliant portion at least 24" long, provided a required clear floor or ground space is centered on the accessible length of the counter.

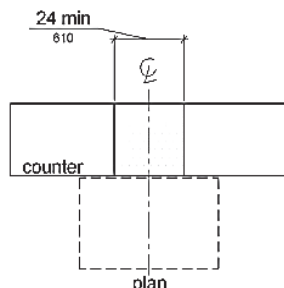

- A counter surface at least 36" long and 36" above the finished floor will be provided. A clear space will be positioned for a parallel approach, adjacent to the counter.
- Where a provided counter is less than 36" long, the entire counter will be 36" high.
- When a portion of counter space is at least 30" long and 36" high, knee and toe space will be provided under the counter. A clear floor space will be there for a forward approach.

Compliant Food Service Lines

- Requirements apply to self-service shelves and dispensing devices for tableware, dishware, condiments, food and beverages.
- Tops of tray slides will be 28"-34" above the finished floor.

Security Glazing

- Where service counters have security glazing, voice communication will be provided.
- Provided telephone handset devices will be handicapped accessible.

- Assistive listening devices can facilitate voice communication when security glazing distorts audible information. If devices are installed, use signs to indicate availability.
- Other voice communication devices include grilles, slats, talk-through baffles, intercoms or telephone handsets.

review questions...

28. Elongated openings will be placed so their long dimension is _____.
- In line with the direction of vehicular traffic
 - Perpendicular to the dominant direction of travel.
 - Diagonal to the direction of vehicular traffic
 - Less than 6" long
29. Benches will have seats at least _____" long and _____" deep
- 42, 20-24
 - 36, 18-20
 - 54, 20-24
 - 54, 18-20

RECREATIONAL FACILITIES

The goal of this section will be to look at those ADA standards better enabling the use of recreational facilities by the disabled.

Recreational Opportunities

General

Unless otherwise specified, provisions apply to recreation facilities and elements, wherever these elements are provided. For example, office buildings having an exercise room must comply.

Accessible Amusement Rides

- These do not apply to mobile or portable rides, regularly assembled and disassembled, like in traveling carnivals, state and county fairs and festivals.
- They do apply to newly designed and built amusement rides and attractions, new on their first use when patrons take the ride. With amusement rides purchased from others, "new" refers to the first permanent installation of the ride, whether used off the shelf or modified before installation. If amusement rides are moved after several seasons to another area of the park, or to another park, the ride is not "new."
- Some rides and attraction, like "virtual reality" rides, have unique features not addressed by these requirements, so they can only be applied to the extent most possible. But an accessible route must still be provided to them. When an attraction has unique

features to which no provisions apply, at least one those features must be on an accessible route.

- When structural or operational characteristics of a ride are altered enough that its performance differs from that of the original design, the ride must be made accessible.
- Routine maintenance, painting and changing of themes do not constitute an alteration.
- Where load and unload areas serving existing rides are newly designed and constructed, those load and unload areas will be accessible.
- All rides will be served by accessible routes, and load and unload areas serving accessible amusement rides will be accessible. If compliance is not structurally or operationally feasible, ramp slope may be a maximum of 1:8. However, the least possible slope should always be used on accessible routes serving amusement rides.
- A turning space will be provided in load and unload areas.
- When there are wheelchair spaces in amusement rides, floor or ground surfaces of wheelchair spaces will be stable and firm, with a slope no steeper than 1:48.
- Amusement rides other than those controlled or operated by the rider, designed primarily for use by children or those without seats; must provide at least one wheelchair space, one seat designed for transfer and/or at least one transfer device.
- Floors of amusement rides with wheelchair spaces will be coordinated with floors of load and unload areas, so when rides are in the load or unload position, any vertical difference between floors will be within +/- 5/8" and horizontal gaps a maximum of 3" under normal load conditions. If not possible, then use ramps, bridge plates, or similar devices.
- Where provided, securement devices for rides can overlap required clearances.
- Wheelchair spaces will provide a clear width of at least 30" and a clear length of at least 48", measured at 9" above the floor.
- When wheelchair spaces are entered only from the side, amusement rides will have sufficient maneuvering clearance for individuals with mobility aids to enter and exit.
- The amount of clear space needed in a ride, and the size and position of an opening, are interrelated. A 32" clear opening does not provide sufficient width when entered through a turn into an amusement ride. Additional space for maneuvering and a wider opening is needed when a side opening is centered on the ride.
- Objects may protrude a maximum distance of 6" along the front of a wheelchair space, when located

9"-27" "above the floor or ground. Objects may protrude a maximum 25" along the front of the wheelchair space, when located more than 27" high.

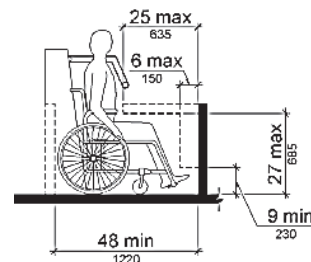

Protrusions in Wheelchair Spaces in Amusement Rides

- Openings to wheelchair spaces on amusement rides will be at least 32" wide.
- One side of the wheelchair space will adjoin an accessible route when loading.
- When the interior width of an amusement ride is greater than 53", seating can be for more than one rider, and if the wheelchair is not required to be centered in the ride, a companion seat will be provided.
- When an amusement ride provides shoulder-to-shoulder seating, companion seats will be shoulder-to-shoulder with adjacent wheelchair spaces.
- Amusement ride seats designed for transfer will meet requirements for clear floor or ground space and required heights of 17"-19" for transfer elements above the floor when positioned for loading and unloading.
- Amusement ride seats for transfer to a mobility assist device may be 14"-24" high.
- Wheelchair storage space that does not overlap required means of egress or accessible routes will be provided at unload areas for each required amusement ride seat.
- Transfer devices for use with amusement rides should allow individuals to make independent transfers from mobility devices. These can include: transfer systems, lifts, mechanized seats and custom designed systems. Where a series of transfers is required to reach the amusement ride seat, each vertical transfer should not exceed 8".

Accessible Recreational Boating Facilities

- Accessible boat slips should be dispersed throughout various types provided, based on size of the boat slips; whether single or double berths, shallow water or deep water, transient or longer term lease, covered or uncovered and whether slips are equipped with features like telephone, water, electricity or cable connections.
- "Boat slip" refers to any pier area, other than launch ramps, where recreational boats are moored for purposes of berthing, embarking or disembarking.
- Accessible boat slips will be provided in numbers complying with the table below. Where specific boat

slips are not identified or marked for individual use, each 40' of boat slip edge along a pier's perimeter is counted as one boat slip meeting requirements.

- Clearances will be required at boat slips and boarding piers at boat launch ramps.

Table 235.2 Boat Slips

Total Number of Boat Slips Provided in Facility	Minimum Number of Required Accessible Boat Slips
1 to 25	1
26 to 50	2
51 to 100	3
101 to 150	4
151 to 300	5
301 to 400	6
401 to 500	7
501 to 600	8
601 to 700	9
701 to 800	10
801 to 900	11
901 to 1000	12
1001 and over	12, plus 1 for every 100, or fraction thereof, over 1000

- Although the minimum required width for clear pier space is 60", it is recommended they be wider than 60" to improve safety for the disabled, particularly on floating piers.

- Boat slips will provide clear pier space at least 60" wide, and at least as long as the boat slips. Each 10' maximum linear pier edge serving boat slips will contain at least one clear opening at least 60" wide.

- Clear pier space can be 36" wide for a maximum length of 24", provided each 36" wide segments is separated by segments that are at least 60" wide and 60" long.

- Edge protection is permitted at continuous clear openings, provided it is a maximum 4" high and maximum 2" wide.

- Where boarding piers are provided, at least 5 % but no fewer than one will be accessible.

- Accessible routes will serve recreational boating facilities, including gangways and floating piers. Adherence to guidelines is not required in the situations below.

— Where an existing gangway or series of gangways is altered, the increase in the length of the gangway need not comply.

— Gangways need not comply with maximum rise requirements.

— Where total length of a gangway serving as part of a required accessible route is at least 80', gangways may have running slopes steeper than 1:12, but not steeper than 1:8.

— Where facilities contain fewer than 25 boat slips and the total length of the gangway serving as part of a required accessible route is at least 30', gangways may have running slopes steeper than 1:12, but not steeper than 1:8.

— When gangways connect to transition plates, landings will not be required.

— Where gangways and transition plates connect and are required to have handrails, handrail extensions will not be required.

— Cross slopes for gangways, transition plates and floating piers that are part of accessible routes will be measured in the static position.

— Changes in level will be permitted on surfaces of gangways and boat launch ramps.

- In existing facilities, clear pier space can be located perpendicular to the boat slip and extend the width of the boat slip, where the facility has at least one compliant boat slip and further compliance would result in reducing the number of boat slips available or reducing the widths of existing slips.

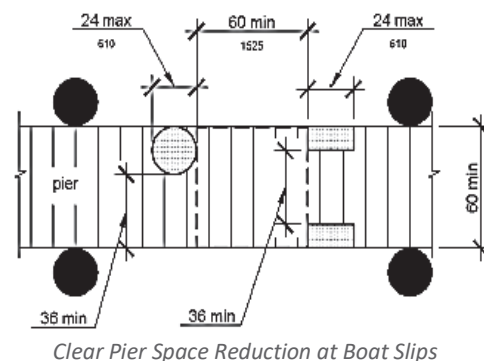
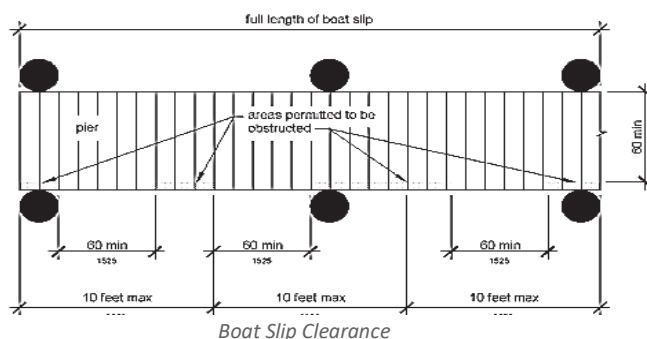

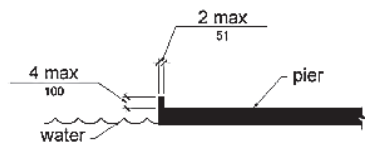

Edge Protection at Boat Slips

- Requirements do not establish a minimum length for accessible boarding piers. An accessible pier should have a length at least equal to other boarding piers provided. If there is no other pier, the accessible one should be as long as what would have been provided, if no access requirements applied.
- Required boarding pier dimensions are very much the same as those for piers with boat slips, as evidenced by the following illustrations.

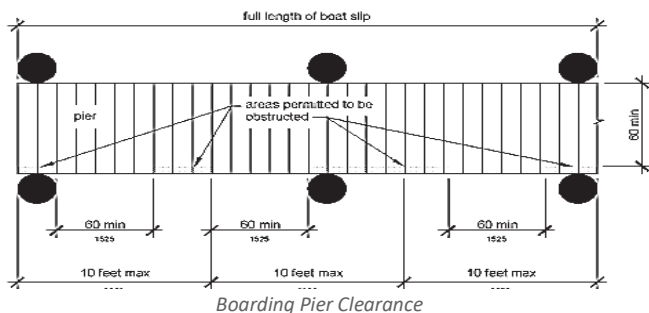

Boarding Pier Clearance

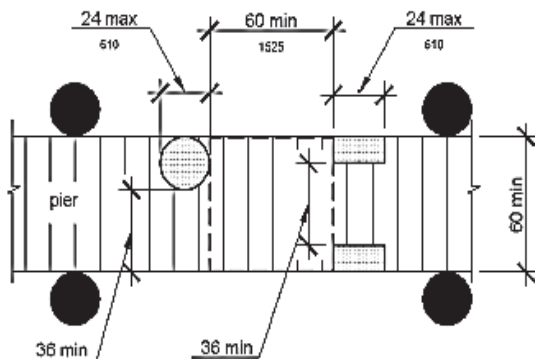

Clear Pier Space Reduction at Boarding Piers

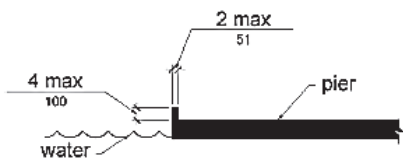

Edge Protection at Boarding Piers

Accessible Fishing Piers and Platforms

- Accessible routes for fishing piers and platforms have the same exceptions listed earlier.
- Where a total gangway is an accessible route and at least 30' long, it need not comply.
- Unless required otherwise by building codes, at least 25

% of provided guardrails or handrails will be a maximum of 34" above the ground or deck surface and dispersed throughout the fishing pier or platform.

- Portions of railings lowered to provide fishing stations for the disabled must be located in a variety of locations on the fishing pier to provide varying water depths, shade, vegetation and proximity to the shoreline.
- Where guardrails or handrails are provided on a pier, edge protection will be provided to prevent mobility devices from slipping off. Extending the deck 12", where a 34" high railing is provided, permits individuals in mobility devices to pull into a clear space and move beyond the face of railing. In such a design, curbs or barriers are not required.

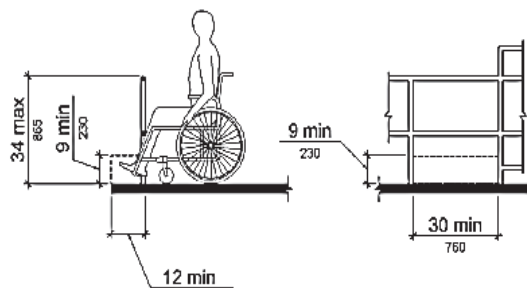

Extended Ground or Deck Surface at Fishing Piers and Platforms

- When used, curbs or barriers will extend at least 2" above the pier.
- When a ground or deck surface is extended at least 12" beyond the inside face of a railing, toe clearance will be provided, at least 30" wide and at least 9" above the ground or deck surface beyond the railing.
- At each location where there are railings, guards or handrails, a clear floor or ground space will be provided. Even when there are no railings, guards or handrails, at least one clear floor or ground space will be provided on fishing piers and platform.
- At least one turning space will be provided on fishing piers and platforms.

Accessible Exercise Machines and Equipment

- At least one of each type of exercise machine and equipment will be accessible. Note that most strength training equipment and machines are considered different types, even when different types can be used for the same exercise.
- Machines need clear floor space for transfer or use by those in a wheelchair. Space at exercise equipment can overlap, and be shared between two pieces of equipment.
- Location of needed clear floor space will vary, depending on the use of the equipment.

Accessible Golf Facilities

- When one teeing ground is provided for a hole, a golf car must be able to enter and exit the tee. When two teeing grounds are provided for a hole, the forward one will be designed so a golf car can enter and exit. When three or more teeing grounds are there, at least two tees, including the one forward, will be designed so a golf car can enter and exit. Unless the terrain prohibits compliance.
- Putting greens will be built so a golf car can enter and exit.
- Where provided, weather shelters will be built so a golf car can enter and exit.
- At least 5 %, but no fewer than one practice putting greens, practice teeing grounds and teeing stations at driving ranges will be built so a golf car can enter and exit.
- Accessible routes serving teeing grounds, practice tees, putting greens, teeing stations at driving ranges, course weather shelters, golf car rental areas, bag drop areas and course toilet rooms will be at least 48" wide, permitting the passage of an adapted golf car.
- Handrails are not required, but if provided, accessible routes will remain at least 60" wide.
- Where curbs or other barriers prevent golf cars from entering a fairway, openings at least 60" wide will be provided at intervals not exceeding 75 yards.
- A clear floor or ground space, at least 60" x 96", will be provided in weather shelters.

Accessible Miniature Golf Facilities

- At least 50 % of the holes on miniature golf courses must be accessible, preferably placed to provide as much of an equivalent experience as possible.
- Miniature golf courses will have accessible holes be consecutive and will provide an accessible route from the last accessible hole to the course exit, without passing through other course holes. The sequence can be broken if the last accessible hole is the last course hole before the exit.
- Playing surfaces are not required to be accessible.
- Where accessible routes intersect hole playing surfaces, a maximum 1" curb will be permitted for a width of at least 32".
- A slope no steeper than 1:4, for a maximum 4" rise, will be permitted.
- Ramp slopes will not exceed 1:20 and ramp landing lengths will be at least 48" x 60".
- Clear floor or ground space at least 48" x 60", with a slope no steeper than 1:48, will be provided at the start of play.

- All areas within holes where golf balls rest will be within 36" of a clear floor or ground space, at least 36" wide and 48" long, with a slope no steeper than 1:20. Such clear floor or ground spaces will be served by an accessible route.

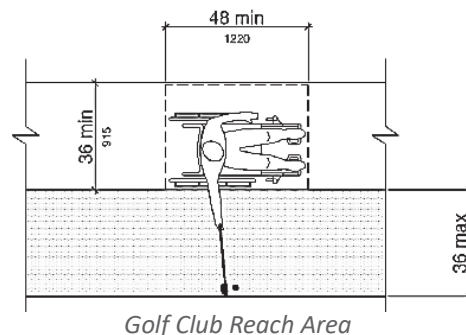

Play Areas

- Play areas for children 2 and older will be accessible, and when separate play areas are provided for specific age groups each play area will be accessible.
- Family child care facilities, where a proprietor resides, need not comply.
- Existing play areas where components were relocated to create safe use zones, and ground surfaces were not altered or extended for more than one zone, need not comply.
- If play components are altered, but ground surface is not, those surfaces need not comply.
- Where play areas are provided for the same age group on a site, but are geographically separated, they are considered separate play areas and each area must comply.
- Where play areas are designed and built in phases, each successive addition and its route must be accessible, so when finished, the entire play area complies with requirements.
- Play components will also be accessible.
- Ground level play components will be provided on accessible routes, per the table that follows. Ground level play components will satisfy the number required, if minimum required types of play components are also provided. Where two or more ground level components are provided, they must be dispersed and integrated with other components.
- Examples of ground level play components include: spring rockers, swings, diggers and stand-alone slides. The general experience provided by the play component is used to distinguish between types. Examples of different types of experiences include: rocking, swinging, climbing, spinning and sliding.
- Accessible ground level play components must be integrated into play areas so as to foster interaction

and socialization among children. Grouping all components usable by disabled children in one location is not integration.

- If a stand-alone slide is provided, an accessible route must connect the stair base to the slide’s exit point. A ramp or transfer system to the top of the slide is not required.
- Where a sand box is provided, an accessible route must connect to the sand box border. Accessibility to a sand box is enhanced by providing a transfer system into the sand, or providing a raised sand table with knee clearance.
- Ramps are preferred over transfer systems, since not all children can use transfer systems.
- Ramp runs connecting ground level play components will have slopes no steeper than 1:16, and the rise for any ramp run will be a maximum of 12”.
- Where ramps connect elevated play components, the maximum rise of any ramp run is limited to 12”. Where possible, provide ramps sloped less than the 1:12 maximum. Berms or sculpted dirt can provide elevation and be part of accessible routes to play structures. Platform lifts are permitted, but may not be appropriate if independently operable.
- When accessible routes serve ground level play components, they must be at least 60” wide, with a vertical clearance at least 80” high.
- At least one of each type of ground level play component provided should be accessible and on an accessible route. They should be provided at the ratio shown in the table below. If at least 50 % of elevated play components are connected by a ramp, and at least 3 elevated play components connected by the ramp are different types of play components, the play area shall not be required to comply with the table below.

- Where a large play area includes two or more composite play structures for the same age, the total number of elevated play components on all composite play structures must be added to determine additional numbers and types of ground level play components to be provided on an accessible route.
- Where elevated play components are provided, at least 50 % must be on an accessible route at least 60” wide, reduceable to 44” where play areas are 1000 SF or less, and 36” for lengths of 60” long or less, connected by segments that are still 60” wide.
- The clear width of accessible routes connecting elevated components will be at least 36”.
- A double or triple slide in a composite play structure is one elevated play component. Ramps, transfer systems, steps, decks and roofs are not considered play components.
- Some play components attached to a composite play structure may be approached or exited at ground level or above grade, from a platform or deck. Where transfer systems at least 24” wide are provided, an elevated play component may connect to another elevated component as part of an accessible route.
- Play components attached to a composite structure, approached from a platform or deck, are considered elevated play components. They are not ground level play components and do not count toward requirements for ground level components.
- ASTM publications establish a uniform means to measure and compare characteristics of surface materials, to determine materials are safe surfaces under and around equipment.
- These standards apply when an accessible surface is required inside a play area, but a fall attenuating surface is also required, and they establish a nationally recognized safety standard for public playground surfaces.

Table 240.2.1.2 Number and Types of Ground Level Play Components Required to be on Accessible Routes

Number of Elevated Play Components Provided	Minimum Number of Ground Level Play Components Required to be on an Accessible Route	Minimum Number of Different Types of Ground Level Play Components Required to be on an Accessible Route
1	Not applicable	Not applicable
2 to 4	1	1
5 to 7	2	2
8 to 10	3	3
11 to 13	4	3
14 to 16	5	3
17 to 19	6	3
20 to 22	7	4
23 to 25	8	4
26 and over	8, plus 1 for each additional 3, or fraction thereof, over 25	5

- “Use zones” are ground areas beneath and adjacent to a play structure, designed to circulate around equipment, and on whose surface it is predicted a user will land when falling.
- If the use zone of a playground is not entirely surfaced with an accessible material, at least one accessible route within a use zone must be provided from the perimeter to all accessible play structures or components within the playground.

- When the surface of the accessible route, clear floor or ground spaces or turning spaces serving water play components is submerged, it need not comply.
- Transfer systems will be permitted to connect elevated play components in water.
- Personal wheelchairs and mobility devices may not be appropriate for submerging in water, when using play components in water. Some may have batteries, motors, and electrical systems subject to damage and possibly contaminating the water. Providing an aquatic wheelchair of non-corrosive materials will protect water from contamination and avoid damage to personal wheelchairs.
- Ground surfaces in play areas must be inspected and maintained to ensure continued compliance with ASTM standards. The type of surface material selected and play area use will determine the frequency of inspection and maintenance activities.
- Transfer platforms will be provided where transfer is intended from mobility aids. Moving between transfer platforms and a series of transfer steps requires extensive exertion. Minimize the distance between the points where a child transfers from a mobility device and where elevated play components are located.
- Transfer platforms will have level surfaces, at least 14" deep and 24" wide, and be 11"-18" from the ground or floor surface. They will have transfer space beside them with the 48" long dimension centered on, and parallel to, the 24" long side of the platform.

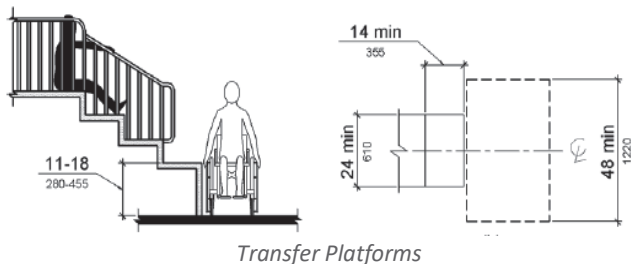

Transfer Platforms

- At least one means of support for transferring will be provided.
- Transfer steps will be provided to move from transfer platforms to levels with elevated play components. These steps will be level, at least 14" deep, at least 24" wide, and a maximum of 8" high.

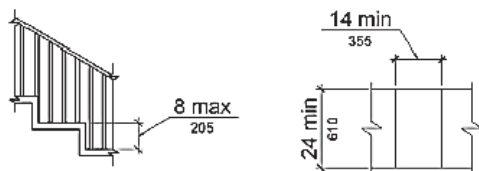

Transfer Steps

- Transfer supports are required on transfer platforms and steps to assist children when transferring. Some

examples of supports include a rope loop, a loop type handle, a slot in the edge of a flat horizontal or vertical member, poles or bars or D rings on corner posts.

- At least one turning space will be provided on the same level as play components. Where swings are provided, the turning space will be immediately adjacent to the swing.
- Clear floor or ground spaces, turning spaces and accessible routes are permitted to overlap in play areas. Specific locations are not designated for clear floor or ground spaces or turning spaces, except near swings, because each play component may require spaces in a unique location. Where play components include a seat or entry point, an unobstructed transfer from a wheelchair or other mobility device is recommended. This enhances the ability of children with disabilities to independently use play components.
- The following table provides guidance on reach ranges for children in wheelchairs and applies to either forward or side reaches.

Children's Reach Ranges			
Forward or Side Reach	Ages 3 and 4	Ages 5 through 8	Ages 9 through 12
High (maximum)	36 in (915 mm)	40 in (1015 mm)	44 in (1120 mm)
Low (minimum)	20 in (510 mm)	18 in (455 mm)	16 in (405 mm)

- Where play tables are provided, knee clearance at least 24" high, 17" deep and 30" wide will be provided. Tops of rims, curbs or other obstructions will be at most 31" high. Play tables primarily for children 5 years and younger need not comply, when clear floor or ground space is arranged for a parallel approach.

Accessible Swimming Pools, Wading Pools, and Spas

- At least two accessible means of entry will be provided for swimming pools. These will be swimming pool lifts, sloped entries, transfer walls, transfer systems or pool stairs.
- When a swimming pool has less than 300 LF of swimming pool wall, only one accessible means of entry will be required, if it is a swimming pool lift or a sloped entry.
- Wave action pools, leisure rivers, sand bottom pools and other pools where user access is limited to one area, need not provide more than one accessible means of entry, provided the accessible means of entry is a swimming pool lift or a sloped entry.
- Catch pools need not provide an accessible entry if the edge is on an accessible route.
- Where more than one means of access is provided into swimming pools, it is recommended means of entry be different, and in different locations, to better serve needs of people with disabilities to get in and out.

- Pool walls at diving areas, and areas along pool walls where landscaping or adjacent structures prevent entry, are counted when determining needed accessible entries.
- At least one sloped entry will be provided for wading pools.
- At least one accessible means of entry will be provided for spas, either a swimming pool lift, transfer walls or a transfer system. When spas are provided in a cluster, no more than 5 % but no fewer than one spa in each cluster must be accessible.
- At least one pool lift will be located where water level does not exceed 48", unless the entire pool is deeper than 48".
- There are a variety of seats available on pool lifts ranging from sling seats to preformed or molded seats. Pool lift seats with backs are the most usable. Additional options like armrests, head rests, seat belts and leg support will enhance accessibility.

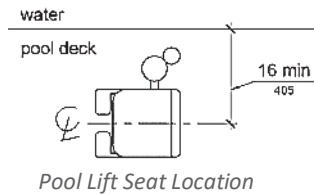

- When lifts are in a raised position, the centerline of the seat will be located over the deck, at least 16" from the edge of the pool. The deck surface between the centerline of the seat and the pool edge will have a slope no steeper than 1:48.

- On the side of the seat opposite the water, a clear deck space at least 36" wide and extending forward 48" from a line located 12" behind the rear seat edge will be provided parallel with the seat. The deck space will have a slope no steeper than 1:48.

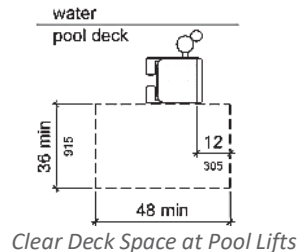

- The lift seat will be at least 16" wide, and the lift will allow a stop at 16"-19" from the deck to the top of the seat when it is raised (in the load position).

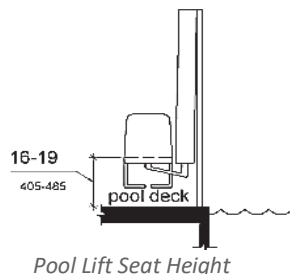

- Footrests will be provided and move with the seat. If provided, an armrest positioned opposite the water can be removable or fold clear of the seat when the seat is in the raised (load) position. Footrests are not required on pool lifts provided in spas.

- The lift will be capable of unassisted operation from both deck and water levels.
- Lift seats will submerge to a water depth of at least 18"

below the stationary water level.

- Single person pool lifts will have a weight capacity of at least 300 pounds and sustain a static load of at least one and a half times the rated load.

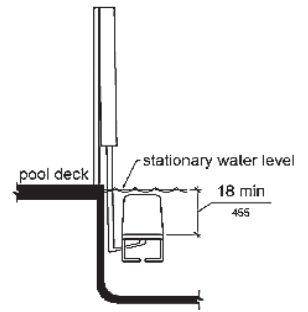

Pool Lift Submerged Depth

- When using sloped entries, consider providing an aquatic wheelchair made of non-corrosive materials and designed for access into the water to protect water from contamination and avoid damage to mobility aids.
- Where sloped entries are provided, surfaces will not be required to be slip resistant.
- Sloped entries will extend down to 24"-30" below the stationary water level. Where landings are required, at least one landing will be located 24"-30" below water level.

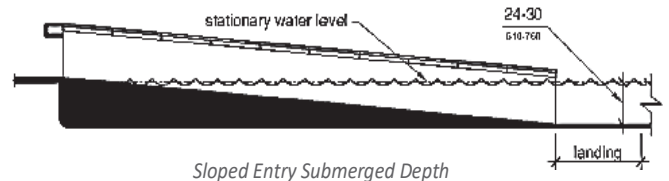

Sloped Entry Submerged Depth

- In wading pools, a sloped entry will extend to the deepest part of the wading pool.

- At least two handrails will be provided at a sloped entry, with a clear width between them of 33"-38". Handrail extensions are not required at the bottom landing of a sloped entry.

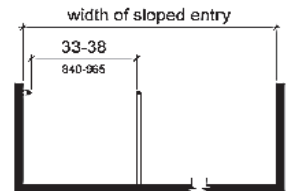

Handrails for Sloped Entry

- Where a sloped entry is provided for wave action pools, leisure rivers, sand bottom pools and other pools where user access is limited to one area, handrails need not comply with clear width requirements.
- Sloped entries in wading pools need not provide handrails.
- Transfer walls will have a clear deck space of at least 60" x 60", with a slope no steeper than 1:48, provided at the base of the transfer wall. Where one grab bar is provided, the clear deck space will be centered on the grab bar. Where two grab bars are provided, the clear deck space will be centered on the clearance between the grab bars.

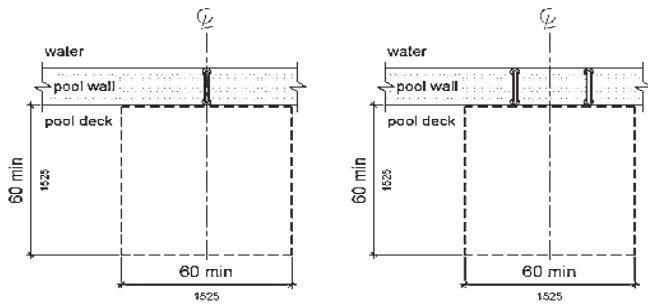

Clear Deck Space at Transfer Walls

- The height of a transfer wall will be 16"-19", measured from the deck.
- Transfer walls will be 12"-16" wide, at least 60" long, and centered on clear deck space.
- Surfaces of transfer walls will not be sharp and will have rounded edges.

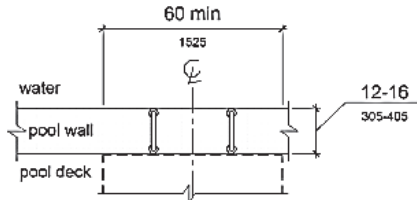

Depth and Length of Transfer Walls

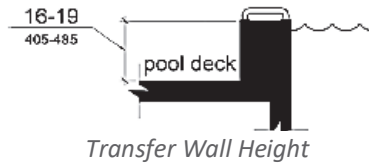

Transfer Wall Height

- At least one grab bar will be provided on the transfer wall, perpendicular to the pool wall and extending the full depth of the transfer wall. The top of the bar will be 4"-6" above the wall. Where one grab bar is provided, clearance will be at least 24" on both sides. With two grab bars, clearance between bars shall be at least 24".

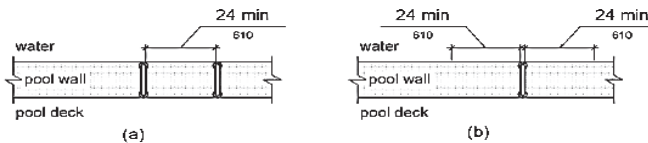

(a)

(b)

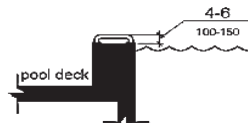

Grab Bars for Transfer Walls

- A transfer platform with at least 19" clear depth and 24" clear width will be provided at the head of each transfer system.
- A transfer space at least 60" x 60", with a slope no steeper than 1:48, will be provided at the base of a transfer

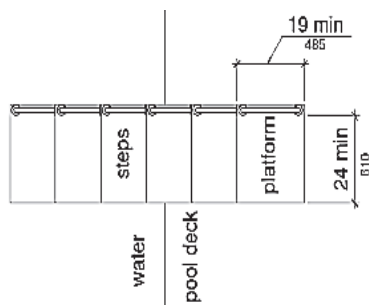

Size of Transfer Platform

platform surface, centered along a 24" side of the transfer platform. The side of the platform serving the transfer space will be unobstructed.

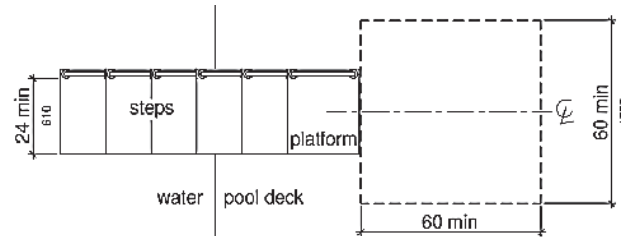

Clear Deck Space at Transfer Platform

- Transfer steps will be a maximum of 8" high, but minimized as much as possible to decrease how far an individual must lift up or move down to reach the next step and gain access. The surface of the bottom tread will extend to at least 18" below the stationary water level.

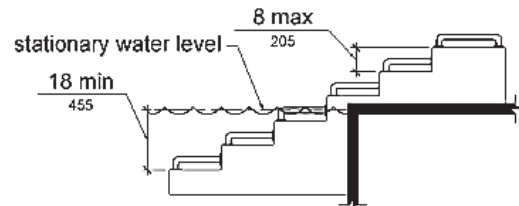

Transfer Steps

- The transfer system surface will not be sharp and will have rounded edges.
- Each transfer step will have a clear tread depth of 14"-17" and a clear tread width of at least 24".

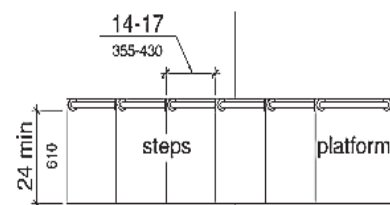

Size of Transfer Steps

- There will be at least one grab bar on each transfer step and transfer platform, or a continuous bar serving each transfer step and the platform will be provided and not obstruct transfer. When provided on each step, tops of bars will be 4"-6" above each step and platform. When a continuous grab bar is provided, the top of the gripping surface will be 4"-6" above the step nosing and transfer platform.

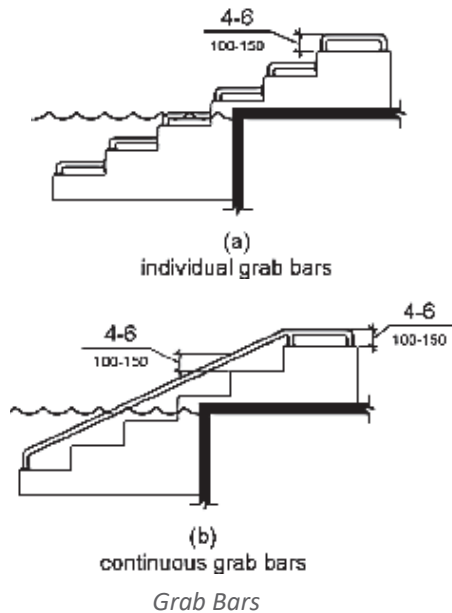

- Pool stairs will comply, except that pool step riser heights will not be required to be 4"- 7" high, provided that riser heights are uniform.
- The width between pool stair handrails will be 20"-24", and handrail extensions will not be required.

Accessible Shooting Facilities with Firing Positions

- At least 5 % but no fewer than one of each type of firing position will be accessible.
- A circular turning space with at least a 6' diameter, with slopes no steeper than 1:48, will be provided at shooting facilities at accessible firing positions.

SIMPLIFYING THE ADA REVIEW QUESTIONS W/EXPLANATIONS

SERIES INTRO

1. When do guidelines for accessibility become laws?
 - a. When enforced by inspectors who have a copy of the federal laws
(Inspectors don't create laws, they only enforce them.)
 - b. When punitive damages for non-compliance are awarded in civil lawsuits
(They are already laws at the point where non-compliance becomes possible.)
 - c. After the last exempt building has been grandfathered in.
(Exemptions are exceptions to laws that are already in force.)
- d. When adopted into the regulations of jurisdictions.
(Guidelines are not laws, merely suggestions. But when they are incorporated into laws and codes being written or adopted by specific jurisdictions, in those jurisdictions, such guideline become and take on the force of law.)

2. Apartments or townhouses, leased year-round exclusively to graduate students or faculty, are not subject to transient lodging standards when _____.
 - a. They have multiple bedrooms in each unit
(The number of bedrooms is irrelevant to use.)
 - b. They do not contain public use areas for instruction
(The key word here is 'transient.' Year round housing is not transient in nature, and the absence of public areas for instruction in the same facilities inhibits them from being used to host seminars, for which attendees would require temporary housing.)
 - c. They are used only for visiting alumni
(They are described as leased to students or faculty)
 - d. No current or foreseeable tenants are handicapped.
(There would be no way to foresee that or regulate it.)
3. In residential facilities, common use areas that _____, need not comply with accessibility requirements.
 - a. Contain less than an aggregate area of 3000 SF on one level
(There is no square footage limit on common use areas.)
 - b. Remain locked unless reserved beforehand for use
(There would be no way to regulate or enforce such a provision.)
 - c. Contain only laundry equipment
(Laundry areas definitely need to be accessible.)
 - d. Do not serve accessible units
(If occupants of accessible units cannot access, or do not use, particular common areas, there is no benefit to making the common areas accessible.)

A PLACE TO PARK

4. Passenger loading zones will offer a vehicular space at least _____.
 - a. 96" wide and 20' long
(This is the space needed to accommodate a parked vehicle, whether in a loading zone or in a parking facility.)
 - b. Twice as long as the longest vehicle using it.
(That information could not be ascertained or enforced later)
 - c. 10' wide and 19' long
(The actual dimensions are given in the regulations.)
 - d. Long enough to park two vehicles
(It is dimensions for a space, not plural spaces.)
5. The minimum width of access aisles serving car and van spaces will be _____.
 - a. 60"
(This is the minimum width required to lower a mechanized lift platform from a vehicle, and roll off the same. In reality, more space than that will be needed if a ramp must be lowered and exited from.)
 - b. 9'
(This is not the dimension given in the regulations as a minimum.)
 - c. 32"
(This is not even the minimum width of a hallway.)
 - d. The same as the widest adjacent space.
(A specific dimension is given, otherwise these aisles could be located by motorcycle parking stalls.)

A PATH TO TREAD

6. Platform boarding edges will have a _____ extending the full length of the public use portion.
- 36" high railing, except for turnstiles
(Better hope those turnstiles line up exactly with entry doors to stopped trains)
 - 6" wide yellow line
(That would give chair users a good visual of the edge, if their eyesight was working well.)
 - 42" high guard railing
(Such a barrier would eliminate the ability to board a train.)
 - 24" wide detectable warning surface**
(Those with diminished sight or other handicaps need to be able to enter transit vehicles at many points along platforms, so guardrails will not work well. But they still need ample warning, prior to potentially falling off platforms into the paths of incoming public transit vehicles.)
7. How many entry points on accessible routes are required at soft play structures with four or more entrypoints?
- None
(This is not the number required in the regulations.)
 - One
(This is not the number required in the regulations.)
 - Two**
(This allows handicapped users to enter and exit at two different locations, despite many users coming in or going out the additional entry points.)
 - Four
(This is not the number required in the regulations.)
8. Ground surfaces of a ramp run or landing should extend at least beyond the inside face of a handrail.
- 18"
(This would excessively increase the required widths of ramps)
 - 6"
(This is not wide enough for a secure placement of crutches.)
 - 4"
(This is not wide enough for a secure placement of crutches.)
 - 12"**
(This is a preventive measure to ensure wheelchair casters and crutch tips don't slip off a ramp surface.)
9. Which of the following is NOT a required dimension for accessible ramps?
- Clear width of 36" between handrails
(This is a requirement found in the regulations)
 - Slopes never steeper than 1:6**
(A ramp at a slope of 1:6 would be virtually impossible for a typical wheelchair user to push up, if their mobility assist device is not motorized.)
 - Maximum 30" rise for any ramp run
(This is a requirement found in the regulations)
 - Minimum 60" level landings at top and bottom of each run
(This is a requirement found in the regulations)
10. What is the allowable range for the diameter of a handrail?
- 1"-1½"

(This is not the range of allowable diameters found in the regulations.)

- 1 ¾"-2"
(This is not the range of allowable diameters found in the regulations.)
- 1 ½"-1 ¾"
(This is not the range of allowable diameters found in the regulations.)
- 1¼"-2"**
(This is the exact range of diameters that best fit inside the hand grips of a majority of users.)

ENTRIES THAT ARE BAR NONE

11. Door openings will provide a clear width of at least 32", except a clear width of 36" is required when openings are _____
- Approached at a high rate of speed
(In this case, it would be the wider, the better.)
 - Always locked
(In which case, it doesn't matter how wide it might be, since it won't be opened.)
 - More than 24" deep**
(If an 32" wide opening extends at least 24" before widening back out, a mobility assist device can become jammed between the walls of the opening if it twists even slightly during passage. Hence the wider opening.)
 - Less than 80" high
(The height doesn't change the width needed to pass through.)
12. _____ is the minimum required depth for a front approach to a door, from the push side.
- 42"
(This does not match the number given in the illustration and regulations.)
 - 48"**
(This is taken directly from illustrations given and reflects the distance needed in which to first turn a wheelchair to directly face the door, before pushing it open.)
 - 60"
(This does not match the number given in the illustration and regulations.)
 - 60" tee
(This does not match the number given in the illustration and regulations.)
13. Door and gate spring hinges need to be adjusted so from an open position of _____ degrees, moving the door to a closed position will take at least _____ seconds.
- 90, 5
(This does not match the numbers given in the regulations.)
 - 45, 5
(This does not match the numbers given in the regulations.)
 - 90, 1.5
(This does not match the numbers given in the regulations.)
 - 70, 1.5**
(This delay gives a user in a mobility device, time to begin moving their device forward into an opening after pushing a door open, before the door can close to again block their passage.)

NAVIGATING THROUGH THE BUILDING SPECIFICS FOR SPECIFIC SPACES

14. Where a clear floor or ground space is located in an alcove, or space confined on three sides _____ shall be provided.
- A companion seat
(There would be no place to set such an item.)
 - An adjacent turning circle
(This is a good idea, but an impractical use of space and not required.)
 - Additional maneuvering clearance**
(Additional clearance is required when obstacles on three sides restrict mobility assist devices and allow them to initially move in only one direction, in order to begin changing direction.)
 - Signage indicating allowed use
(People are anarchists and will use space however they wish.)
15. When a forward reach is unobstructed, objects can be _____ above the path.
- 15"-48"**
(This is because with no obstructions, a wheelchair occupant can move to the wall directly below an object, the maximize their upward reach.)
 - Pole mounted
(The pole itself would obstruct forward movement)
 - 24"-36"
(This does not match the numbers given in the regulations.)
 - Pole mounted over 36"
(The pole itself would obstruct forward movement)
16. 1¼" is the maximum clearance allowed between an elevator car platform and any _____
- Manual sliding gate
(These are no longer used in elevators.)
 - Hoistway landing edge**
(Minimizing the gap also minimizes the potential for a partially turned chair wheel to slip down into the space between a platform and the hoistway edge.)
 - Floor indicator designations
(The regulation is for safety at the floor level.)
 - Rails used for automatic braking
(If users can come into contact with braking rails, don't use that elevator.)
17. Which of the following is not true regarding platform lifts?
- They will have low-energy power-operated doors or gates
(This is in the regulations.)
 - Doors shall remain open for at least 20 seconds after activation
(This is in the regulations.)
 - End doors and gates will be at least 32" wide
(This is in the regulations.)
 - They will be attendant operated.**
(Requirements for platform lifts are based on their being directly used by those in mobility lifts, with no help available, so they must be safer and easier to use than those with attendants.)
18. A wheelchair space entered from the front shall be at least _____ deep. When it can only be entered from the side, the space shall be at least _____ deep.
- 48", 72"
(This does not match the numbers given in the regulations.)
 - 36", 48"
(This does not match the numbers given in the regulations.)
 - 42", 60"
(This does not match the numbers given in the regulations.)
 - 48", 60"**
(When the space is entered from the side, it will take 60" in width to be able to turn a wheelchair to face forward)
19. In licensed long-term care facilities, at least _____%, but no fewer than one of each type of resident sleeping room, will provide mobility features.
- 50**
(As long-term care facilities are specifically designed to provide care for those with diminished physical capabilities, and a lack of ability to care for themselves, it makes sense that at least half of their sleeping rooms will be accessible.)
 - 35
(This does not match the number given in the regulations.)
 - 25
(This does not match the number given in the regulations.)
 - 75
(This does not match the number given in the regulations.)
20. In pass through kitchens with two entries, clearance between opposing work areas or walls will be at least _____".
- 42
(This does not match the number given in the regulations.)
 - 40**
(This space between work areas will accommodate a three point turn so a user in a mobility assist device can fully turn to face their tasks.)
 - 38
(This does not match the number given in the regulations.)
 - 48
(This does not match the number given in the regulations.)
21. Guidelines establishing height and position of platforms, coordinated with floor height of the vehicles being served, are called _____
- Leveling the Accessibility Playing Field
(This fictitious name for a publication is not found in these regulations.)
 - Vehicular Access Rules
(This fictitious name for a publication is not found in these regulations.)
 - Accessibility Guidelines for Transportation Vehicles**
(This publication stays abreast of floor heights of vehicles used for public transportation, so that accurate information is available to use in coordinating platform heights, that will be adjacent.)
 - Establishing Commuter Access (ECA)
(This fictitious name for a publication is not found in these regulations.)

USABLE EQUIPMENT AND HARDWARE

22. A shower spray unit with a hose at least 59" long, usable as both a _____ and a hand-held shower, will be provided.
- Fixed-position shower head**
(Shower spray units need to also be usable and convenient for able-bodied users.)
 - Variable spray unit
(Whether the spray is variable or not has no bearing on accessibility.)
 - Shower wall scrub
(Whether a spray unit can be used to clean the walls has no bearing on accessibility.)
 - Shower seat cleaner
(Whether a spray unit can be used to clean the seat has no bearing on accessibility.)
23. In transfer showers, controls, faucets and shower spray units will be installed _____
- On a side wall opposite the seat
(This is included in the regulations.)
 - 38"-48" above the floor
(This is included in the regulations.)
 - On the control wall, a maximum of 15" from the center of the seat toward the shower opening
(This is included in the regulations.)
- d. All of the above**
(These parameters have been established as making the working components of a shower most usable for handicapped users.)
24. Where rear wall space does not permit a grab bar at least 36" long, it can be at least 24" long, _____
- Centered behind the water closet**
(Anything to assist chair users in a transfer, using at least two points of support, is better than nothing.)
 - Centered above the water supply
(The water supply location is variable and not a place to support a load that can slip down.)
 - 12" to the left of a flush valve.
(A flush valve location is variable and has no bearing on where a chair user needs support.)
 - 6" above the lid of the tank
(Needed heights for use are established as distances above the floor, not above fixtures.)

COMMUNICATION FEATURES

25. Temporary signage, not required to comply with disability requirements, is defined as _____
- Mounted with removeable fasteners
(Almost everything uses removeable fasteners, no matter how many years it remains.)
 - Capable of being changed electronically
(A changeable message has no bearing on whether the sign itself is temporary.)
- c. In place for 7 days or less**
(This establishes a waiver for signage requirements, if the sign has been predetermined to be in needed and in place for less than a week.)

- On a location scheduled for demolition
(That's pretty temporary, unless the demolition process takes years to complete.)
26. Raised characters on signs will be at least _____
- 1/8" above their background.
(This does not match the number given in the regulations.)
 - The thickness of a dime
(This does not match the number given in the regulations.)
- c. 1/32"**
(This raised height is the minimum needed to register tactilely to those who use touch to help decipher the meaning of lettering.)
- 1/4"
(This does not match the number given in the regulations.)
27. Telephones with a volume control shall be identified by a pictogram of a _____
- Telephone handset with radiating soundwaves**
(The indicated pictogram is an internationally recognized symbol for such telephones.)
 - Microphone on a stand
(Such an image is not an internationally recognized symbol.)
 - Dial with graduation marks around the perimeter
(Such an image is not an internationally recognized symbol.)
 - Two lips being shushed by a finger
(Such an image is not an internationally recognized symbol.)

FINISHING WELL

28. Elongated openings will be placed so their long dimension is _____
- In line with the direction of vehicular traffic.
(This creates openings into which chair wheels can drop or become lodged.)
- b. Perpendicular to the dominant direction of travel**
(Openings perpendicular to the direction of travel can easily be traversed.)
- Diagonal to the direction of vehicular traffic
(I'm not sure if I've ever seen a grate designed like this.)
 - Less than 6" long
(That's still plenty long enough to get a wheel stuck.)
29. Benches will have seats at least _____" long and _____" deep
- 42, 20-24**
(These dimensions permit two users to sit side-by-side and allow ample surface area for larger users.)
 - 36, 18-20
(This does not match the numbers given in the regulations.)
 - 54, 20-24
(This does not match the numbers given in the regulations.)
 - 54, 18-20
(This does not match the numbers given in the regulations.)

PDH Academy

AIA CES Course Evaluation

Thank you for completing this evaluation. We want to ensure that our training sessions are as meaningful as possible and appreciate your feedback. Please mail your completed forms to:

PDH Academy, PO Box 449, Pewaukee, WI 53072

If you would like to offer feedback on this course to AIA CES, please visit www.aia.org/CESFeedback

Date: _____

	←—————→				
	Poor				Excellent
<i>Simplifying the ADA</i> Course Number: AIAPDH189					
<i>Using a scale from 1 to 5 where 1 is "Poor" and 5 is "Excellent," please evaluate the course in the following areas: (circle one number per question)</i>					
1. Overall satisfaction with this course	1	2	3	4	5
2. Course learning objectives clearly stated and met:	1	2	3	4	5
3. Satisfaction with the format of this course:	1	2	3	4	5
4. Met overall personal objectives for attending:	1	2	3	4	5
5. Quality of course content:	1	2	3	4	5
6. Applicability/value of new knowledge, ideas or information:	1	2	3	4	5

How could these courses be improved?

What other topics would be of interest?

Additional Comments:
