



Architects

# Aging in Place: Practical Solutions

Course Number: AIAPDH263

2 LU|HSW

---

PO Box 449 Pewaukee, WI 53072 (888) 564-9098

[arch-support@edcet.com](mailto:arch-support@edcet.com)

## Final Exam – Aging in Place: Practical Solutions

1. Illustrated guidelines for handicapped access to public facilities were published by the \_\_\_\_\_ .
  - a. National Handicapped Institute
  - b. Center for Disease Control
  - c. National Council for Aging-in-Place
  - d. United States Access Board
2. How wide do sidewalks need to be before two wheelchairs can pass one another?
  - a. 3 feet
  - b. 4 feet
  - c. 5 feet
  - d. 6 feet
3. \_\_\_\_\_ is an exterior surface considered to be the worst for mobility.
  - a. Pea gravel
  - b. Concrete with a stiff broom finish
  - c. Cinder block with minor gaps between
  - d. Permeable paving
4. Plants that \_\_\_\_\_ should not be used.
  - a. Produce poisonous berries
  - b. Attract unwanted pests
  - c. Have thorns
  - d. Stay compact as they grow
5. To permit wheelchair access, a drop from the top of a threshold to an outside surface is best kept to a maximum of \_\_\_\_\_ .
  - a. 1 /4"
  - b. 7 /8"
  - c. 3 /4"
  - d. 1 /2"
6. If possible, \_\_\_\_\_ should be eliminated leading to entries of homes.
  - a. Doors containing keyed access
  - b. Wind chimes
  - c. Steps
  - d. Parking spaces
7. An area considered minimal for turning around in a wheelchair has \_\_\_\_\_ .
  - a. Hard surfaces for flooring
  - b. A clear five-foot radius
  - c. Grab bars to assist in rotation
  - d. No raised areas within it
8. If possible, all necessary spaces in a home where aging-in-place can occur should \_\_\_\_\_ .
  - a. Be in clear line of sight
  - b. Contain space for a hospital bed
  - c. Be available on one single level
  - d. Contain at least one phone jack

9. Unless they are taped down or have proper backing, \_\_\_\_\_ may become tripping hazards.
  - a. Wipe-off mats
  - b. Area rugs
  - c. Office chair mats
  - d. Chairs on castors
10. Frequently used items should be on shelving, no lower than \_\_\_\_\_ and no higher than \_\_\_\_\_.
  - a. Lap height, head height
  - b. 24", 57.5"
  - c. Counter height, eye level
  - d. Waist level, shoulder level
11. The top of an accessible toilet should be between \_\_\_\_\_ and \_\_\_\_\_ inches.
  - a. 14, 16
  - b. 15, 17
  - c. 16, 18
  - d. 17, 19
12. The best cabinet hardware for use with arthritic hands is \_\_\_\_\_.
  - a. Loop cabinet pulls
  - b. Round knobs
  - c. Drawers with no pulls
  - d. Bar pulls
13. Any place where they are in proximity to water, power outlets should be \_\_\_\_\_.
  - a. At least 48" above the floor and 12" above a counter
  - b. On a GFI circuit
  - c. Well lit and easily located at night
  - d. Connected to an audible alarm
14. If front loading laundry appliances are used, they should be raised off the floor \_\_\_\_\_.
  - a. On recessed pedestals
  - b. Between 12-15 inches
  - c. No more than 24 inches
  - d. High enough to create knee space below
15. Approaching an opening straight on, \_\_\_\_\_ inches of clear opening is needed for wheelchair passage.
  - a. 34
  - b. 36
  - c. 32
  - d. 31.5

# **AGING IN PLACE: PRACTICAL SOLUTIONS**

## **INTRODUCTION**

In millions of homes in our country, aging parents and other occupants face steps needed to exit from their homes. These are steps they no longer have confidence or strength to negotiate. They also face life with a bewildering array of technology with which they have never felt comfortable. Bathrooms have become dangerous places. Their own second floors and basements are no longer even accessible to them. They must sometimes grope their way through a fog of confusion, just to accomplish daily tasks that were once mundane and second nature.

Some problems they face cannot be helped. But many can, with the simple installation of equipment and hardware, or a few modest changes in routine. This writing is to familiarize others with problems faced by our aging population and possibly ourselves, along with suggestions on how to mitigate these issues in our residences.

## **THE SCOPE OF THIS WORK**

Every design or building issue dealing with the disabled or handicapped cannot be dealt with here. Massive laws have been passed for the purpose of guiding design decisions for buildings intended for use by the disabled. Many of these focus on commercial buildings, institutional projects and multi-family housing of various types. Where published guidelines for public facilities cross building types, I will touch on them. Since pictures are worth more than words, where possible, I will include graphic illustrations of guidelines from the United States Access Board.

My focus here, however, will be on private residences, becoming more difficult to use as we age. Aging-in-place simply refers to the desire to stay in a familiar home as long as possible in life. It is the “ability to live in one’s own home and community safely, independently and comfortably, regardless of age, income or ability level.” The easiest way to do that is to adapt the living facilities to changes in physical capabilities, to enable the ninety percent of polled seniors who want to stay home as they age.

We will look at what can be done to make it possible to stay in homes for as long as possible, despite the debilitating effects of advancing age.

## **PROBLEMS TO BE EXPECTED WITH AGING**

Known problems faced by our aging population, can best be explained by the potential loss of our ability to:

- Climb up and down stairs with confidence
- Stand and sit down again on chairs, beds, toilets, etc.
- Get into, bathe and safely exit bathtubs and showers
- Drive and return from destinations, from a standpoint of both physical and cognitive capability
- Bend down and pick up items from the floor or lower shelves
- Easily carry items like grocery bags and laundry baskets
- Successfully use public transportation
- Keep the home and property clean
- Properly use all appliances
- Manage personal health

These issues may all require some modifications be made to a home. So we will systematically explore areas where concerns arise in navigating our environments as we age. This will be followed by known standards, the intent behind their development and possible solutions to the problem being discussed. When we look at possible improvements, the type of print used will give us clues to relative importance.

*Items in italics that are underlined are basic starting points for modifications most likely to be needed.*

*Those items which are only italicized represent the next tier of changes also useful for aging-in-place.*

Those items in normal print are good ideas for various reasons, but a bit lower on priority lists created by limited time and funds.

## **OUTSIDE THE HOME**

Unless they don't intend to participate in life anymore, residents will sometimes need to leave their homes.

### **Public Transportation:**

If driving has become impossible, then a safe place to walk or having access to public transportation will become important to get to necessary basic services. Walking is the oldest method of accessing needed locations and one that brings side benefits for health if done safely and often. If possible to do, the shortest walking distance with safe and accessible routes should be scouted out ahead of time.

When walking is not possible, it should be easy to access public transportation services. Wayfinding signage along normal walking routes should identify transit hubs, exactly as marked on available transit maps. Transportation stops should be welcoming, well-lit and offer a climate-protected place to rest while waiting.

Using cabs and ride-share services is another option. A convenient place to enter taxis and shuttles will be a safe spot with no curb. Even better, if there is covered seating adjacent to that pickup area.

### **Walking Routes:**

Safe walking routes share some common characteristics. Curb cuts are in place to eliminate painful step downs and step ups. Slopes in the route should be easily navigated. There should be a comfortable separation or landscape barriers between the walk and fast-moving traffic. Is the path maintained snow and ice free? No grates with openings along the way should present a hazard to canes, walkers or even mobility-assist devices with thin wheels. Paved surfaces should have slip resistance, with at least a stiff broom finish, and be slightly sloped to one side so water will drain. Walking surfaces should be free of cracks or broken concrete, with smooth transitions between paving materials. Pathways into a destination should be at the same plane as the floor. Crossing areas should be easy to negotiate and it's not a good idea to share walkways with incompatible uses, like bicycling. Walking paths should be simple, easy to navigate and well lit. Gravel paths are difficult to walk through and impossible to roll through, so sidewalks should connect along the whole route. No detours into streets, or walking in streets, should be necessary.

The width of sidewalks controls the traffic on them, especially with wheelchairs.

- 3 Feet: Single user
- 4 Feet: Two people can walk side by side
- 5 Feet: Two wheelchairs can pass

- 6 Feet: Two wheelchairs can travel together

Seek to avoid the need to navigate steps, but if they are on the route, they must have handrails. They should also have rounded edges instead of metal grate surfaces. Slip-resistant strips on stair tread edges are a bonus. Exterior stairs should have risers no greater than 6" high and treads no less than 12" deep.

If a route is of any length, are there intermediate resting places? No matter the path taken, routes should all be wheelchair accessible. If a ramp must be navigated, it should have handrails or curbs if abutting a lower surface or landscaping. Brightly colored strips should be at the edge of any change in plane and used to distinguish roadways from walkways and crosswalks.

### Outdoor Car Parking

Parking for older residents should be as close as possible to their homes, ideally in a carport or garage. But in older locales it may be street parking. For multi-family housing, parking lots will be used. In any event, curb cuts and slopes as shown below are desirable to eliminate level changes like curbs.

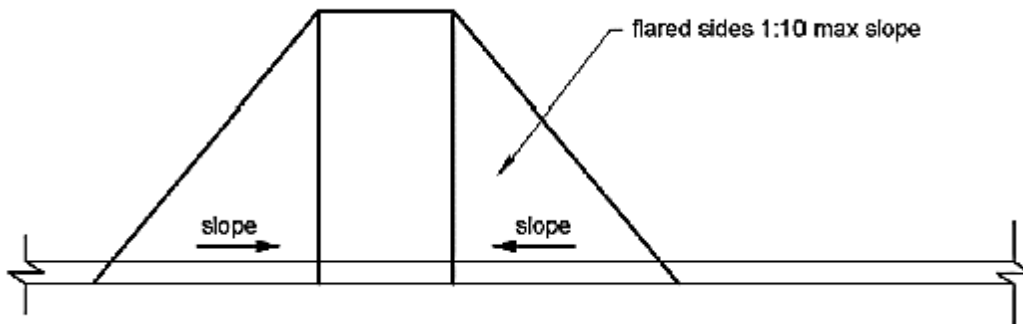

Curb Cuts for Ramps from Parking

If a resident will be using public transportation, pull-up spaces are needed. Some are designed. Some are created by default, when a bus or taxi pulls up alongside a curb cut and blocks traffic to load passengers.

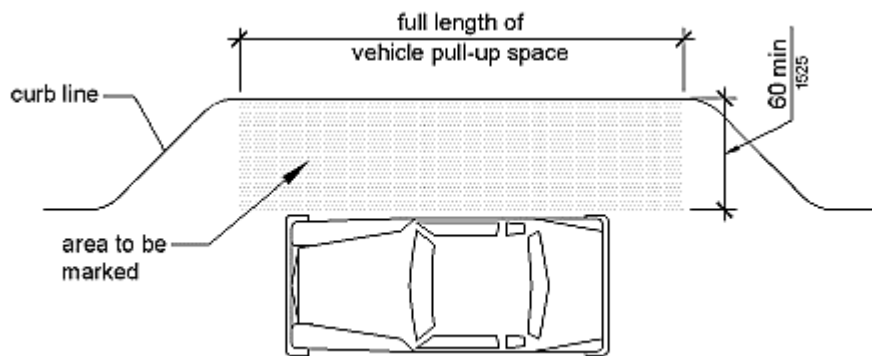

Passenger Loading Zone

Parking spaces should allow easy admission over a paved walkway to a front entry, preferably without navigating steps. If the front entry is higher than the parking area, a sloped walk or ramp will be needed for access.

### **Site Lighting:**

Many accidents and falls can be prevented by adequate lighting in areas needing crossed. Guidelines are available to establish proper light levels for various task. Dim lighting making it hard to define obstacles and bright lighting creates glare. Both are undesirable.

One effective strategy is to focus light specifically where needed, effectively creating outdoor task lighting. Higher, overall lighting can then be dimmer. Use shielded lights to direct the illumination without creating glare elsewhere. Provide step-down lighting levels between areas needing more and less illumination, so eyes have time to adjust to changes. Choose light sources / lamps that provide good color rendition. To save power, use motion activated lights in areas not often used, like dumpsters, walking paths, etc.

Adequate lighting is needed for wayfinding, a navigation tool to direct residents back home. Few people use darker pathways, especially at night. When signage identifies buildings, it should be lit to keep it visible. Provide lights along steps, ramps or any other change in height, to prevent bad surprises while finding they exist. In a similar vein, light transitions from sidewalks to entries so they are not bypassed.

### **Site Furnishings:**

Proper furnishings in an outdoor space can entice residents out into fresh air. Just don't create such spaces on sloped surfaces, as wheelchairs are hard to stop or start when gravity is in play. Leave space to accommodate a wheelchair at one end of exterior seating. Site furnishings should also create places where walkers or talkers may sit, rest and catch their breath. Shade trees, canopies or shelters should protect them from the sun, wind or precipitation.

The ability to reconfigure any space increases its usability. Moveable seating, still heavy enough to resist scooting away from users, is ideal. Armrests assist in rising or sitting and such seating should also have backs. For easy use by the aged, seat heights for chairs should be 17-19" high, with a seat depth of no more than 24".

### **Landscaping:**

Landscaping can be both beautiful and hazardous.

After landscaping is finished, it will still be necessary to navigate a site on hard slip-resistant surfaces. On a sliding scale, pea gravel is the worst for mobility, followed by grass. Pavers as an average surface and finally, rough concrete is the best option. Grass and gravel are tripping hazards and difficult for mobility assist devices. Flagstone walks are beautiful, but natural paving materials are not always uniform in size and can be uneven tripping hazards. All edges of walks or ramps should be marked with a contrasting color if possible.

Some landscape materials are more user friendly. Metal landscape bed edging is hard to see and can cut the unwary, so use bulkier materials. Exposed tree roots are a tripping hazard, but cutting and removing them will likely kill a tree. Instead, reroute pathways so roots are not disturbed. Fencing around property can help easily disoriented users maintain a sense of privacy and stay inside safe boundaries.

Plants used should be chosen for what they will add to the user experience. Shade trees are a welcome relief on hot days. Flowers are always delightful. Shrubs help soften transitions between building and land, but for security purposes, should not obscure sight of an entry. Aggressively growing shrubs will need constant pruning. In short, choose plants that change color to help track seasons, smell good, don't contain or emit known allergens, are not poisonous, don't drop seed pods on walk surfaces, don't attract pooping birds and don't attract unwanted pests, animals or insects.

**Gardens:**

Gardens present multiple dangers, from maneuvering on loose soil to issues caused by repetitive kneeling, bending and standing back up. But certain elements can eliminate some of these risks. Raised beds allow planting, weeding and harvesting without excessive bending. Paved pathways between beds can be wide enough to accommodate wheelchairs. Raised planters in gardens should not too wide to reach across with a wheelchair. Recesses under planters allow better access for wheelchairs.

Other amenities just increase the enjoyment. Greenhouses can enable gardening all year long. A water source and hose should be nearby. One possible option is a drip hose system above planters watering everything below. Tools should be near the garden, so obtaining and returning them is easy. A seat or bench is useful for resting, especially if shaded. Given the potential for falls, weariness and problems from heat, it is a good idea for gardeners to have a device to call for help, should it become necessary.

**Private Exterior Spaces:**

An important contributor to well-being is use of an outdoor space. Getting on and off patios and decks may require some planning, since existing decks and patios are usually constructed one or two steps below living levels, making them inaccessible to the physically impaired. If a new deck cannot be built on an existing patio, to bring it up near floor level, a ramp down will be needed to access that area. Edges of such a deck will be high enough above existing grade to constitute a hazard, so edge protection or railings should also be provided.

Ideally, interior and exterior surfaces would be at the same level. But accomplishing that would still create moisture penetration issues, like melting snow flowing inside a sliding door. Wheelchair access dictates level changes be kept to a maximum of 1/2". Standard doors and French doors use a lower threshold than sliding doors. The latter often uses a threshold several inches high, which must be climbed over by users. Tracks for sliding glass doors can be recessed, but this creates pockets where water will reside, so it is rarely done. Small ramps are possible inside and outside a threshold to help a mobility assist device cross them.

While stepping over a threshold or onto a deck, it is easy to slip or trip. Outdoor surfaces should be non-slip, even when wet. If this is not a natural characteristic, coatings can be added to provide it, including on exterior stair treads. Outdoor surfaces should also be self-draining to prevent ice accumulation.

The matrix below compares exterior deck and patio surface materials, based on care, hazards in use and ease of mobility.

Material	Cost	Ease of Care	Hazards			Ease of Mobility		
			Least Glare	Slip Resist	Trip Resist	Feet	Walker	Wheel chair
Synthetic Decking	Mid	Med Maint	High Glare	Low Slip	Low Trip	Hard	Hard	Hard

				Resist	Resist			
Wood	Mid	High Maint	Med Glare	Med Slip Resist	Low Trip Resist	Medium	Hard	Hard
Pavers	Low	Low Maint	Least Glare	Med Slip Resist	Low Trip Resist	Medium	Hard	Medium
Concrete with a broom finish	High	Low Maint	High Glare	Med Slip Resist	High Trip Resist	Easy	Easy	Easy
Traffic Coating	Mid	Med Maint	Med Glare	Med Slip Resist	High Trip Resist	Hard	Medium	Easy

Outdoor space use may often be predicated on how safe it feels to do so. Decks set outside the exterior plane of homes are felt to be less user-friendly than alcoves recessed into the building’s mass. There is something comforting about partial enclosure. Any open edges off which a wheelchair or walker can roll, make users uneasy.

**Exterior Building Materials:**

Maintaining exterior cladding materials becomes increasingly difficult as aging occurs. With new homes, material choices are easy. If cladding changes will be made to existing homes, the following criteria should be considered. *Exterior materials are best if they are low maintenance, like brick and vinyl siding. Plants and shrubs around the home should also require little maintenance, be slow growing and remain compact.*

**Accommodating Pets:**

Companionship of an animal is an excellent way to overcome feelings of loneliness or isolation, if concerns created by limited mobility and strength can be overcome.

Accessories can make pet ownership easier. *Automatic pet feeders are a great example.* A lightweight, vacuum can easily remove shed hair. A cat box on a raised shelf makes changing kitty litter easier. A waste receptacle with wheels is helpful near a litter box. A raised utility tub with secure tethering points makes it possible to bathe pets without stooping

If a large dog decides to leave the vicinity in a hurry, with an aged owner holding the leash, someone will get hurt. Better to have a dog run built so the animal has some freedom, grass and the outdoors. If the run has a concrete portion, a hose can periodically wash it off onto nearby ground. A dog door leading directly into such a run is very welcome on rainy days.

**Outside the Entry:**

Areas directly outside the main entry seem to be prime locations for accidents to happen. These can be minimized by the following changes. *If possible, eliminate steps leading to entries. There should be at least one handicapped accessible path into the home, involving no level changes. Keep approaches to the building free from debris, loose building materials, rocks and clutter. The entire pathway from a car to an entry should be well lit. Secure handrails should be on each side of any steps.* Paving can have radiant or hot water heating systems installed, to easily melt accumulated ice.

Other changes center more on process of entering. *A minimum 36" wide door will provide the necessary 32" of clear passage through the entry. A motion sensor light should trigger when the resident approaches and adequately light up the lock. The doorbell should be in an obvious accessible location.*

### **Review Questions**

1. If life is to be lived as fully as before, public transportation will become important when \_\_\_\_\_.
  - a. The cost of driving outweighs the benefits
  - b. The ability to park at typical destinations has become prohibitively expensive
  - c. The task of driving has become impossible
  - d. The physical condition of deteriorating roads results in too many repairs to residents' cars
2. \_\_\_\_\_ are used to eliminate a need for possibly painful step downs and step ups.
  - a. Curb cuts
  - b. Mobility-assist devices like Segways
  - c. Paving materials graded absolutely flat
  - d. Small, lightweight personal ramps
3. Exterior obstacles that can prove to be hazardous to canes, walkers and mobility-assist devices are \_\_\_\_\_.
  - a. Thorn bushes
  - b. Curb cuts outside of the path of travel
  - c. Grates with openings
  - d. Sloped pavement
4. The flared sides of a curb cut should have a maximum \_\_\_\_\_ slope.
  - a. 1:10
  - b. 1:12
  - c. 1:4
  - d. 1:8
5. Outdoor gathering areas should not be placed on \_\_\_\_\_.
  - a. Concrete with broom finishes
  - b. Plazas with flowering bushes
  - c. Surfaces known to retain heat
  - d. Sloped surfaces
6. Raised planters in gardens should not \_\_\_\_\_.
  - a. Be too wide to reach across with a wheelchair
  - b. Contain plants that cross pollinate
  - c. Be made from base materials which rot
  - d. Be cost prohibitive to construct
7. As a flooring surface, pavers are considered to have \_\_\_\_\_ and \_\_\_\_\_.
  - a. High maintenance, high glare
  - b. Medium glare, high trip resistance
  - c. Low maintenance, low trip resistance
  - d. Medium maintenance, medium glare
8. \_\_\_\_\_ is an important criterion for choosing exterior building materials as aging occurs.
  - a. Low levels of reflectivity
  - b. Low maintenance
  - c. Resistance to insect infestation
  - d. Colors complimentary to the neighborhood

## INSIDE AN INDIVIDUAL HOME

While preceding subjects dealt with exterior concerns, the remainder of this course will be concerned with changes inside individual homes. This is because for most of our aging population, existing homes are where changes will need made, if they have any hope of aging-in-place.

### In General:

A major first step to enable aging-in-place will be creating needed space in a building already full of a lifetime of treasures. *Declutter the house and eliminate anything no longer necessary, to free up needed space for circulation. This will also remove trip hazards from paths to be taken.* In the long run, any space gained will be worth it for initially irritated aging loved ones. Easy ways to accomplish tasks like clothes washing or cooking, and practical solutions to challenges faced in bathrooms, will also allow continued independence for residents aging-in-place. If help will be needed for certain tasks like bathing or cooking, make sure there is enough space to accommodate both the resident and an aide.

Space is the operative word in adapting a home. Open plans allow flexible use when mobility assist devices are needed. There should be multiple spaces in which a resident can turn around, if confined to a chair. *At a minimum, there should be a 5' by 5' turning area in the living area, kitchen, a bedroom and a bathroom. If it can be created, there should also be a 5' by 5' turning area at the end of a hallway.* A side benefit of freeing up space is creating clearer lines of sight. These allow caregivers and residents to stay in visual contact, a source of comfort to both. A line of sight to the exterior can also comfort the homebound.

Illustrations below indicate the amounts of space necessary to properly navigate in a wheelchair. This needed space is the same, whether a wheelchair is being used in a public setting or a private home.

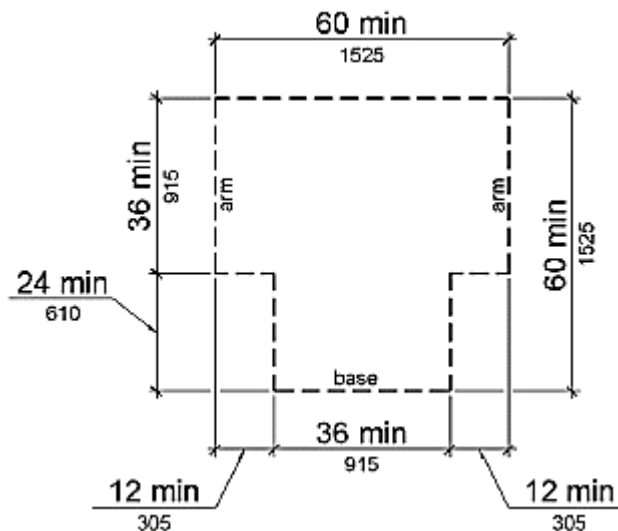

Clearances for a "T"-shaped Wheelchair Turn

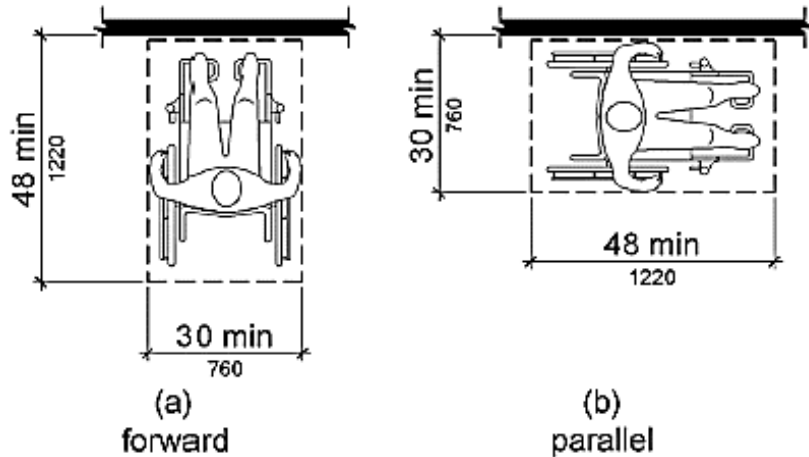

Clear Floor Spaces Needed for Maneuvering

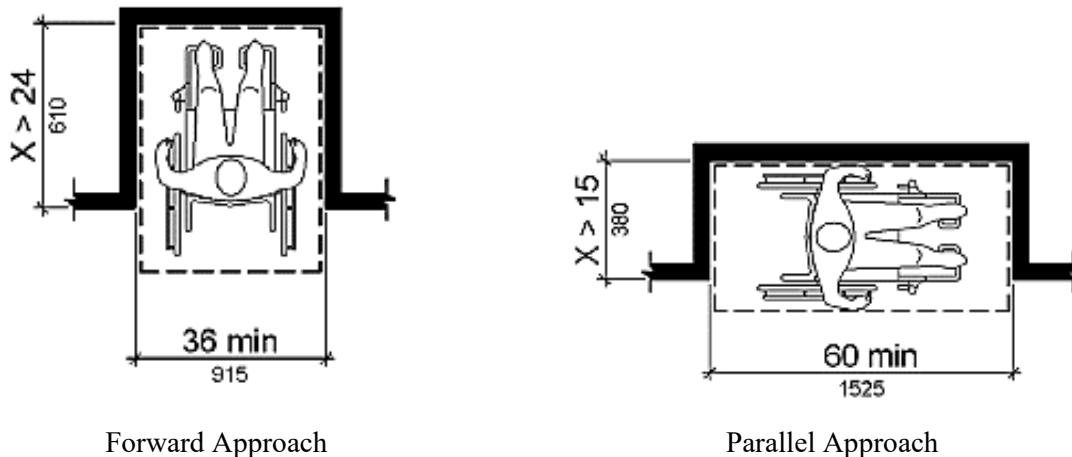

Clear Floor Spaces Needed for Maneuvering in Alcoves

Making an existing home with multiple levels, totally available to use while aging-in-place, may be impossible. Deteriorating knees, hips and backs may simply not permit safely climbing steps. *If possible, all necessary spaces in a home should be available on one single level, with no steps between them.* Even when on the same level, smooth transitions should be made between flooring of different types and thicknesses. Don't let tripping hazards remain. *If renovating with new finishes, choose those which result in easy-to-clean surfaces.* Interior traffic flow and choices of finishes will have a large impact on how long an aging resident can safely remain home.

Sometimes, it will be very helpful to minimize the amount of movement needed to perform daily functions. *If lines of sight are not in place, video phones and intercom systems make it easy to communicate between spaces without moving.* Multiple phone jacks and multiple phone extensions reduce how far a resident must travel to answer calls. *A central vacuum system eliminates dragging a stand-alone vacuum from space to space.*

Sooner or later, some level of compromise will be needed in how they were accustomed to living, in order to stay home. Space used for one function in the past, can always change functions to accommodate new life requirements. Living rooms can become bedrooms as easily as bedrooms can become studies, once a door is removed. Repurpose available space as needed, not based on past or traditional use.

Storage is needed to age-in-place, including places to store mobility assist devices until needed. Storage should be available in numerous locations for duplicate items, made to minimize memory issues. In this way, residents won't need to go far to find another pair of glasses, keys, etc., when unable to locate the last ones they had.

### **Flexible Spaces:**

Existing, but otherwise inaccessible *second or lower levels* can be otherwise used. *If a caregiver will be needed, a separate apartment can be created for them or rented for secondary income until needed. If there is a little more space on a main level than currently needed, it can become a playroom for visiting children, an office, or if combined with a bathroom and kitchenette, a small apartment for a parent to age-in-place.*

### **Foyer / Entry:**

The transition between the exterior and interior of a home is often the most hazardous, but some things can reduce risk. Wayfinding signage inside a house entry can guide residents to the nearest transit stops. Posting copies of public transportation schedules and maps near the exit can aid in memory and in planning excursions. The address of the building should be in large text outside the entry. Upon arrival, a navigable surface should be provided from the pick-up or parking area to the front entry. In multi-tenant buildings with internal corridors, level changes should not be a problem between entry, hallway or the units.

Paving outside a front entry should be even with, or only slightly lower than, flooring inside the entry. Otherwise, sloped paving or a ramp may become necessary. *Thresholds at entry doors should be flush if possible, but at most, have a drop of 1/2" to the exterior and 1/4" to the interior. Lobbies or foyers should have shelves inside and out for packages, to free up hands to open the door.*

Visibility should be excellent at entries. The door should be clearly lit at night, with no shadows cast on the card reader or keyhole. Inside, adequate hallway lighting should illuminate readily identifiable doors to each unit. A light switch for the interior of the home should be available immediately upon entering. Entries should be protected from the weather. Since fatigue is a contributing factor to falls, a bench should be provided outside the front entry. Once past the door, a bench should also be provided inside the front entry. A closet should be near to hang a coat, a place to sit and remove wet boots, and a place to drop off a wet umbrella. These will all prevent water being carried inside onto other flooring surfaces. The closet for removed items keeps them from becoming tripping hazards.

Despite precautions, moisture in a foyer is almost certain. *So entry surfaces, inside and outside an entry, should be slip-resistant.* Walk-off mats can be useful to minimize tracked-in moisture.

Because of their vulnerability, security a big concern of the aging. An audible and visual cue should alert residents when visitors or deliveries are at the door. *It should always be possible for residents to determine a visitor's identity, without opening the door. Dual height peepholes can be used by standing residents or those with mobility assist devices. Viewing panels do this as well, but can create issues with security.* Regardless of whether they can be seen, make it possible to communicate with visitors without opening the door. A locked drop box that goes through the wall can be used for small deliveries like medicine, without requiring the front door be opened to a stranger.

Front entry hardware should be easy to use. *Entry doors should have push or lever style hardware.* Lever hardware is also available that can be operated by a card reader. *If a traditional key will be used, have the lock be a contrasting color from the door, so the keyhole is easy to see.*

### **Living Room:**

Residents will want to spend a lot of time here, if they can. This room should have enough space for different furniture arrangements, while maintaining clearance to maneuver, even with mobility assist devices. If there is shelving, access some from wheelchair height. If doors cover shelving, glass in them makes it easier for forgetful residents to determine what is inside.

Choosing proper flooring will enhance usability. Changes in flooring color can alert residents with poor eyesight when they are transitioning to another space. It is tempting to let carpet remain or use rugs to add a feeling of warmth. Unless taped to the floor or with rubber backing, area rugs may be tripping hazards.

There is a built-in problem with large overstuffed furniture. If seats are too deep or too low, getting in and out quickly presents a challenge. One answer is to eliminate reasons to rise quickly. Universal remotes with large icons can control heating/cooling, lighting, television, security and even answer the phone. Some are programmable to perform multiple tasks with one touch of a button. If such a remote is purchased and programmed, make sure its use is easily understood.

### **Kitchen / Dining:**

Cooking was likely a central part of the lives of our elders. Appetite somewhat diminishes with aging and eating may become less enjoyable, but not doing so will have devastating health consequences. Since the ability to go out for food may also be restricted, continued kitchen use will be important. The following are just a few ways to make that possible.

Safety will always be a big priority. Make sure stoves don't have knobs that initiate a flow of gas when merely bumped. Induction cooktops are a great invention and worth investigating. Install smoke and carbon monoxide detectors and test them regularly.

As aging progresses, extra space may be needed in kitchens for ordinary tasks. If a mobility-assist device is in use, it may not be possible to approach a task from the same direction. Below are code recommended clearances for kitchen tasks and for using dining rooms. Meet or exceed these space requirements.

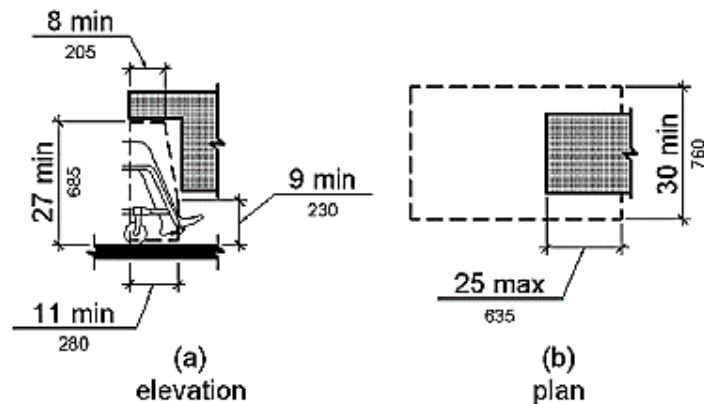

Required Knee Clearances

Operating space for appliances is a big part of adapting kitchens for aging-in-place. Doors needing opened, like oven and dishwasher doors, must have space to do so, even when the user is in a mobility assist device. Verify there is room to approach and operate each appliance. Dishwashers should still be next to sinks for ease of plumbing and for loading. There must be open work space on countertops next to appliances.

Kitchen / Dining Cabinets:

Existing kitchen cabinetry may not work well for the elderly. *Some base cabinets can be removeable to create knee space for wheelchair users.*

Countertops may need to be changed or adjusted. *Provide support in the walls for varied heights of counters and cabinets.* Adjustable height countertops with knee space below, work great when only one family member uses a mobility assist device. The top should be no more than 34” above the floor. Lower breakfast bars that are open below, also work well with wheelchairs. Rounded corners on countertops reduce contact injuries. *Make sure there is space beside each appliance to set dishes down.* Use low reflective materials for countertops to reduce glare. If new counters are being ordered, *specify a colorful edge banding to define countertop edges, especially if the counter and floor will be similar in appearance.*

The illustrations below denote counter heights for best use with wheelchairs.

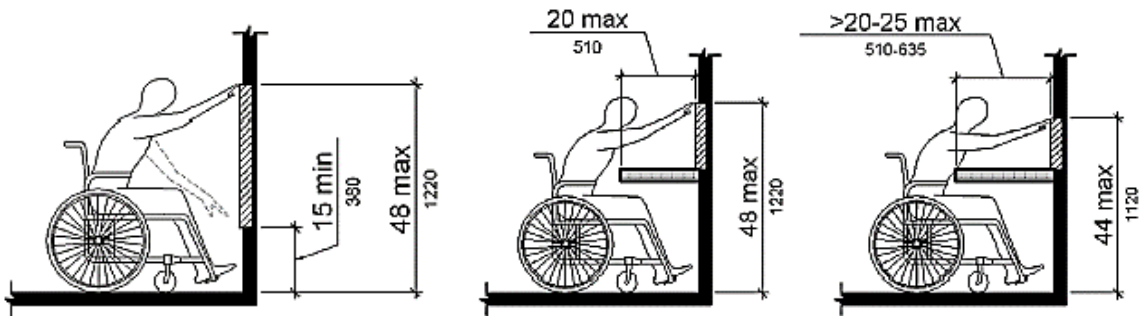

Unobstructed Forward Reach

Obstructed Forward Reach

Cabinet use may also require some scrutiny.

Whether cabinets will be used, changes with the difficulty of doing so. Replace base cabinets with drawer base cabinets. Lower upper cabinets to make them more reachable. *Consider open shelving for frequently used items. Ideally, these should be no lower than waist level and no higher than shoulder level. Pull down shelving works well for seniors. Base cabinets with pull-out drawers and / or Lazy Susan’s are easier to use than ones with shelves.* Pantries or pantry cabinets reduce storage of food in upper cabinets. Do not install any cabinets reached by leaning over potentially hot surfaces.

Changing cabinet accessories can make them easier to use. Soft closing cabinets are preferred. *Loop cabinet pulls work best for aged fingers. Round knobs and doors and drawers without hardware are difficult. Lighting mounted under upper cabinets supplements general overhead lighting.* Glass doors on cabinets, or door labels, helps residents determine contents at a glance. If dealing with dementia, lockable cabinets may be needed for some medications or foods to which a resident is sensitive.

Kitchen / Dining Appliances:

Besides establishing or maintaining work triangles, kitchen layouts must include consideration of space needed to approach appliances and task areas. Some example layouts below illustrate space needed to do so.

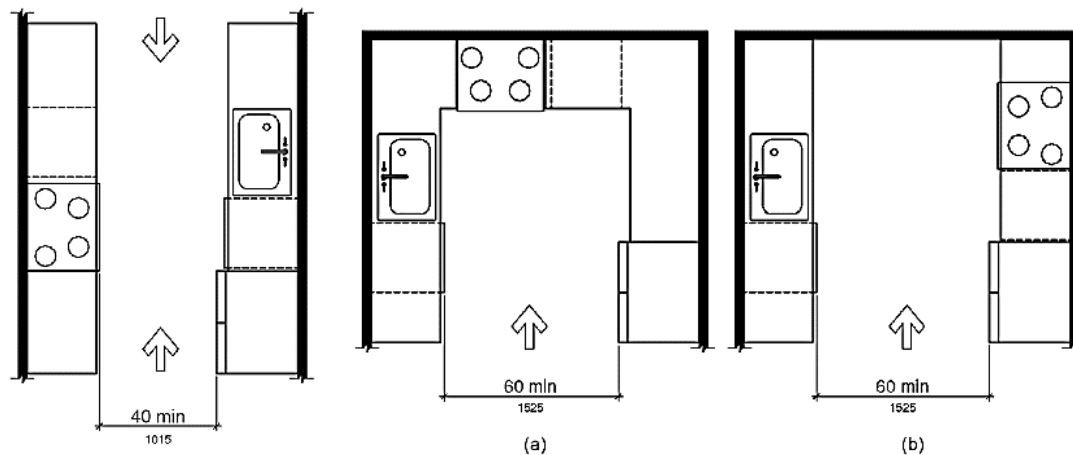

Kitchen Layouts

In addition to these, there are general guidelines for safe use of kitchens by the elderly. *All appliances should have easily understood controls.* Push button controls are better than knobs needing twisted. *There should be a clear space of 30" by 48" in front of each appliance, or a turn-around space with a 60" diameter.* Thoughts on specific appliances follow.

Floor space should be available beside dishwashers to easily load them. *Raise dishwashers if needed for easier access and use easy-to-read controls.* There are even drawer dishwashers that can be mounted under the counter, ideal for use whether standing or seated.

*Do not mount microwaves above stoves. It is far safer to have them on countertops, mounted in a wall or in lower cabinets.*

*To maximize access by users in wheelchairs or scooters, use side by side refrigerator / freezer combinations or a unit with the freezer drawer at the bottom.*

Stoves are the appliance most needing changed for safety. *When replacing these, avoid gas appliances. Electric or induction cooktops are much safer. If dementia is a concern, use a lockable cover or kill switch, with the switch hidden somewhere it is not obvious. A downdraft feature can draw heat away from the user. Lights should indicate when a surface is still hot. Side swing or wall ovens are the best choices for this appliance.* If using a wall mounted oven, place it at a height to minimize bending and lifting. Provide anti-tipping brackets on appliances, especially on stoves.

#### Kitchen / Dining Plumbing:

Kitchen sinks may also need to be modified for continued use. Sinks should be shallow enough that faucets can be reached from a sitting position. *Faucets should use lever style handles and pull-out spray faucets.* Faucets should have mixing valves incorporating anti-scald protection. Limit faucet rotation to prevent spills. Faucets with sensors eliminate the need to use hands. Pedal controls can also be used to make faucets hands-free. If knee space is created below for chair access, cover or wrap exposed piping to prevent burns.

#### **Bathrooms:**

A usable bathroom is critical for aging-in-place. There should be a full bath accessible on the main living level. As with kitchen use, space will be a critical component in this. If wider doors are needed to properly enter, consider a pocket door or use clear offset or expandable hinges. There should be a turnaround space inside the main bathroom, at least 30" by 48", or a circle with a minimum radius of 60". If a caregiver is needed to assist in bathing, make sure there is enough space in a shower for that. Water controls should be accessible to the caregiver.

The diagrams below show recommended space around bathroom fixtures. Most will not be attainable in retrofits, but they set goals for which we reach.

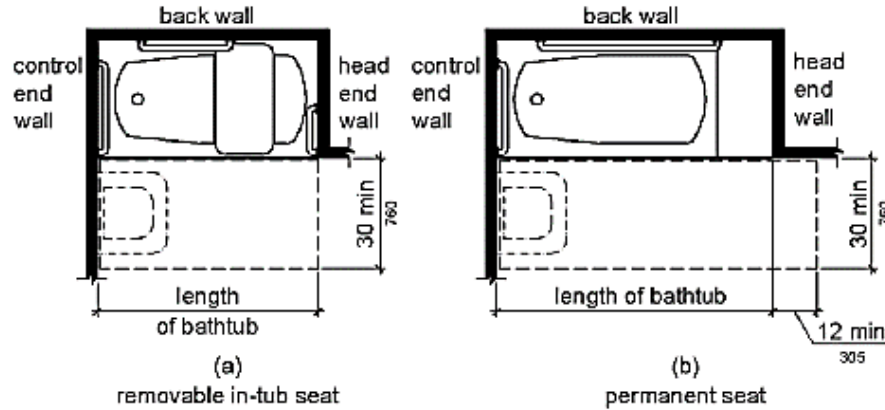

Clearances for Bathtubs

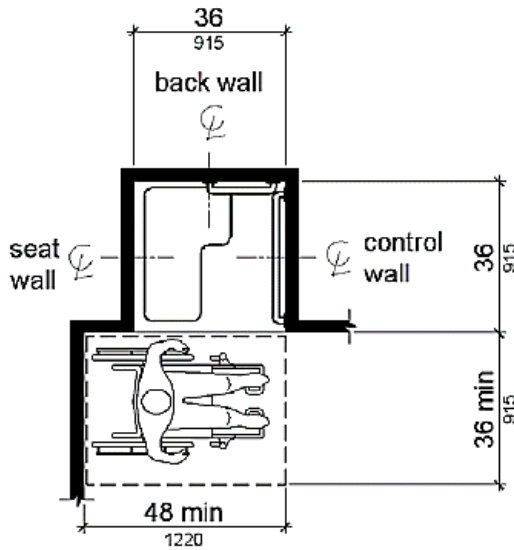

Note: inside finished dimensions measured at the center points of opposing sides

Transfer Shower Size / Clearance

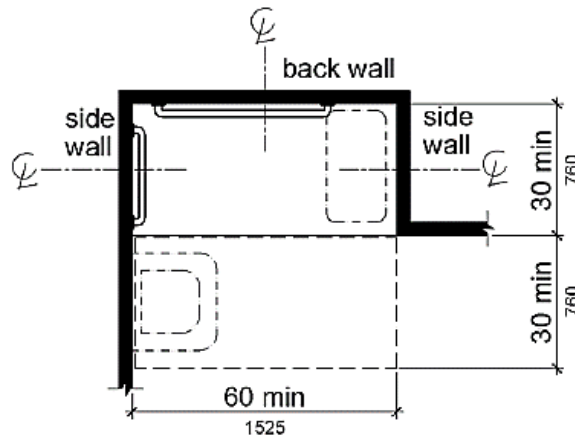

Note: inside finished dimensions measured at the center points of opposing sides

Standard Roll-in Shower Size / Clearance

There should be an accessible height toilet, or a standard toilet with a raised seat. The top of that seat should be between 17" and 19" from top of seat to the floor, or be height adjustable.

Existing lavatories will likely need replaced or modified for accessibility. If tall enough, a wall mounted sink with a removeable base cabinet can provide necessary knee space, by just removing the cabinet. Pedestal sinks allow easier chair access but may not provide enough room on top for personal items. Since

*pipes will be in proximity to knees, use a mixing valve with thermostat settings to prevent accidental scalding. The maximum allowable water temperature should be 120 degrees. If possible, install pressure balanced faucets. Faucets can also be pedal-controlled or have lever handles.*

Showers are a primary means of bathing for elder use and require special attention. *Stand-up showers need to be a minimum of 36" wide and are best with built-in antibacterial protection.* Use a hard enclosure with a curb free door, not a curtain providing no help to a falling resident. Don't install doors on tracks on top of tubs. They are a major obstacle to climb for someone exiting. *Showers should be without curbs or have only a low threshold, so wheelchairs can be rolled. There should be a fold-down seat in the shower or a standalone bath bench. Texture strips or non-skid rubber mat on tub or shower bottoms will prevent slipping.*

Tubs are problematic for the elderly. Some models allow entry at floor level, with a self-sealing door to be closed before filling the tub. But these are very expensive and not often purchased. *Lower height bathtubs are a compromise, easier to enter and exit. These units have the disadvantage of holding less water, but still requiring balance, coordination and strength to use.*

*Regardless of whether in a tub, shower or combination thereof, a handheld shower spray should be used with offset controls and at least a six-foot-long hose. That will help prevent overspray out on the floor outside the unit. Tub / shower controls should be offset from the center.*

#### Bathroom Cabinets:

*Cabinetry inside existing bathrooms will likely need changed. Provide backing inside walls for adjustable height countertops with removeable base cabinets to create knee space. If a wheelchair need be accommodated, standard vanity cabinets are not an option. Install a wall-hung sink so there will be knee space below it. The top of such a sink should be a maximum of 34" above the floor. If lower cabinets can still be used, base cabinets with pull-out drawers work better than cabinet doors with shelving behind them. If a vanity is long enough, one cabinet can be left out below to create a knee space for grooming. Where knee spaces have exposed pipes, wrap plumbing to prevent burns.*

Additional changes to bathrooms can help maximize use. Rounded countertops will minimize injuries. Use countertop materials that are not very reflective, to minimize glare. *A colored stripe on the edge of counters may be needed to distinguish counter edges from the floor below.* Should there be wall mounted cabinets, provide them with glass shelves so contents can be easily identified.

#### Bathroom Hardware:

Arthritic hands will appreciate further attention to details. Loop cabinet pulls work best for aging-in-place. Round knobs and doors and drawers without hardware are difficult to use. Bar pulls can catch on clothing and initiate falls. If dealing with dementia, lockable cabinets may be needed for some medications.

#### Bathroom Accessories:

Installing certain accessories in bathrooms provides additional measures of safety. This is especially true of adding grab bars. *If possible, install bars at the toilet and near tubs and showers. Provide backing inside walls for grab bars to which a resident can cling when slipping or stepping in or out of a bath or shower. These grab bars should support up to 300 pounds.* Grab bars in the shower and by the toilet should have backing behind them as well. Towel rods should never be used for support.

Seats should be available for use in showers and tubs. These can be fold-down versions, permanently built-in or just a portable stool. The best option for safety is a built-in shower seat. Some examples of seat configurations are shown below.

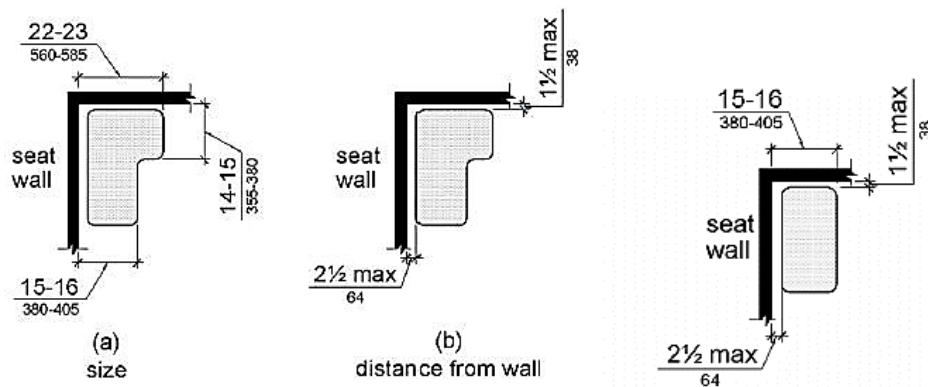

Shower Seat Examples

Some modifications are easy to accomplish. Mirrors should be hung at a height and be tall enough to accommodate someone sitting or standing. Installing mirrors that can be angled downward is one way to accomplish this. *Pick a dispenser model that makes it possible to restock toilet paper with one hand.* Place towel bars and shower robe hooks very close to exits from showers and tubs. Users should not have to stretch and risk falling off balance, to get a towel or robe. Have storage easily accessible in bathrooms for personal items and supplies for incontinence.

#### Bathroom Finishes:

As with any space where water will be present, options for finishes should be carefully considered. *Provide slip resistant flooring in areas where standing water can occur.* When considering slip resistance, using smaller tiles with more grout lines creates more slip resistance than using larger tiles. *Rugs commonly used as a warm place to set feet in bathrooms, can be tripping hazards. If used, they should have rubber backing or be secured down with double-sided tape.*

Selected materials should be easy to clean, preferably without creating hard to clean corners at intersections. Epoxy grout is the best choice for resisting the build-up of contamination.

Use tiles at the base of walls that present a clear color contrast to the flooring. This will help residents clearly identify the transition points of room boundaries.

#### Bathroom Power:

*Make sure there is enough light in bathrooms to perform needed tasks.* Lighted switches will help older residents easily locate the controls at night. *One light should be above the shower or tub.* Make sure mirrors are well lit on each side to eliminate shadows. Night lighting, or lights triggered by motion, also come in handy during middle of the night visits.

Placement and replacement of electrical outlets in bathrooms are dictated by safety concerns. Don't place outlets right next to sinks where they will be directly exposed to water. All outlets in proximity to wet locations should be GFI outlets. Make sure outlets above cabinetry can still be reached from wheelchairs.

Outlets can also be placed on the face of cabinetry but must not be located where spilled water can run over their face.

Other safety concerns may dictate additional electrical changes. Have an emergency call button or cord in bathroom locations, reachable from the most likely locations for falls. Heat lamps above the shower / tub are also appreciated by those who are sensitive to cold.

### **Bedrooms:**

As health deteriorates and mobility decreases, more and more time will be spent in bed. That sounds like an amazing opportunity, unless someone has no choice otherwise.

Space will again be an issue in this room. There may be real difficulties obtaining this, if a wheelchair must be used to access an existing bedroom. That will be discussed in other sections. The more cluttered the bedroom, the more difficult it will be to move from the bedroom to a nearby bathroom, or to the rest of the home. *There should be enough space in any bedroom to maneuver around the furniture, which at a minimum should be a bed and a dresser. At least one nightstand should also be able to be accommodated.* Glasses, false teeth, needed medications and remote-control devices should be within easy reach of the bed.

The diagrams below indicate clearances desired around a bed and in an adjacent bathroom.

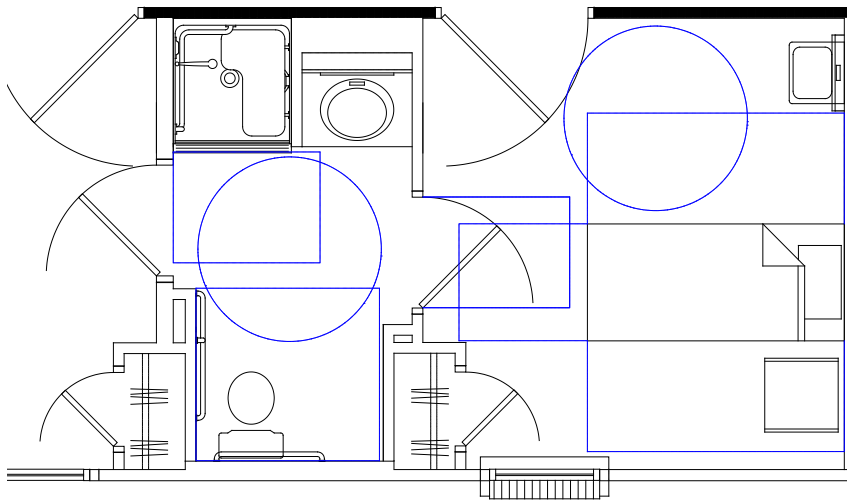

Layout of Bedroom and Adjacent Bath with Needed Clearances in Blue

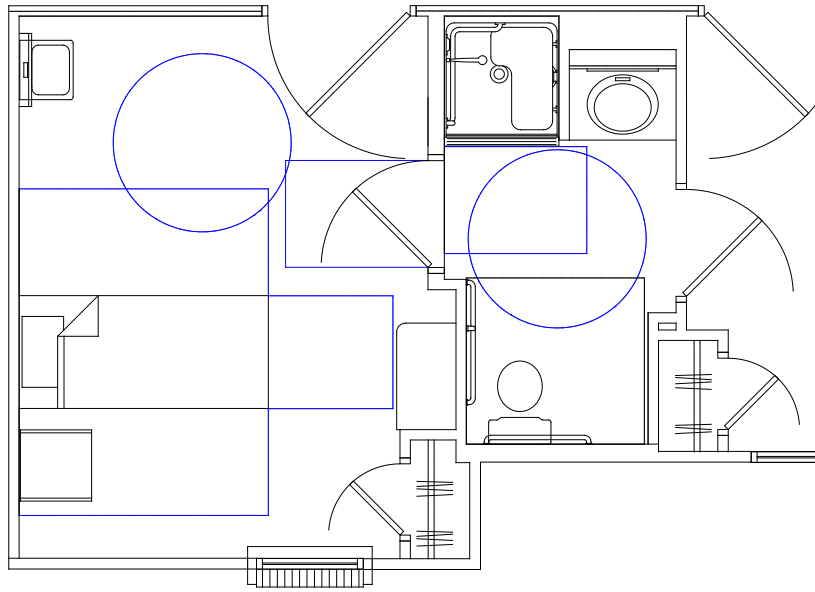

Layout of Bedroom and Adjacent Bath with Needed Clearances in Blue

Enough space should be in this room to accommodate a hospitable type bed, should one become necessary. If an existing bed will be used, *move the bed against one wall to prevent it sliding away while being sat upon or entered. If the height of the existing bed makes it difficult to use, raise it by using a thicker mattress or lower it with a thinner one as needed. Attach a handrail to a wall near the bed to support a resident when they first arise. This will give time for circulation and balance to increase before further movement.*

Power considerations for a bedroom are as follows. Two ways switches are handy for lights in bedrooms, one at the door coming in and the other next to the bed. There should be a clear line of sight or a clear path from the bed to a bathroom at a minimum. If there are no night lights to illuminate the path from bedroom to bathroom, a light switch should be near the bed to turn lights on. Phone jacks or charging stations should be next to the bed, so aging residents don't have to struggle out of bed to answer a ringing phone. The more items in the room that can be controlled with a remote device, the better. Universal, programmable devices for this can be purchased.

#### Bedroom Closets:

Existing closets may be difficult to retrofit, to meet the following needs. *Doors should be wide enough to present easy access to closets, even using a wheelchair. If a closet is a walk-in, it will also need enough clear floor space inside in which to turn such a wheelchair around.* Closets can be used both to hang clothes and store other household goods. Consider turning portions of closets into drawers to hold clothes and eliminate the need for dressers in the adjacent bedroom. *Closets should have adjustable rods and shelves. One or more clothes rods should be low enough to be accessed from a wheelchair. If possible, closets should have a light inside, with a protective cover on the light to prevent breakage.*

#### Bedroom Flooring:

Consider the following when choosing finishes for bedroom floors. Wood floors are easier to maintain dust free by users suffering from allergies, but this choice will often seem stark to residents used to softer flooring. And obviously, softer flooring is a safer choice for those prone to falls. Carpet can add a feeling

of warmth to the floor, but if used, it should have a low, tight pile that minimizes the possibility of tripping or stumbling. Heavy patterns on carpet can be interpreted as obstacles by aging eyes. One often used alternative to carpets is providing wood flooring, with area rugs beside beds. *Note that loose area rugs can be a real tripping hazard and if not secured to the floor, a slipping hazard. If used, they should have rubber backing or be secured down with double-sided tape.*

### **Laundry Room:**

Access to, and the use of a laundry facility in the home, will need to be accommodated. *Given increasing issues with balance and strength, a laundry room located near bedrooms will reduce the distance baskets need to be carried. A direct opening, even if only a chute between laundries and bedrooms, is even better.*

Door selection, and the space taken up by the swing of the door, are important in laundry spaces. If machines are in an alcove off a hallway or another room, bi-fold doors on a laundry closet will block part of the opening, even while open. If possible, barn doors are an option that does not result in partial blockage of laundry closet openings. *There should be turning radiuses inside actual laundry rooms and outside laundry closets opening to hallways. If a room is designated for use as a laundry area, the door must be wide enough to allow passage of mobility devices.*

Wheelchair use should be accommodated. *Seated users will find front load washers and dryers much easier to use than other models. It may be necessary to use a platform or a base from the manufacturer to raise them between 12" and 15" off the floor. Easily understood controls should be on the front face of appliances.*

As with any other space, built-in accessories can make a laundry area more functional and facilitate extended use. There should be lower shelving in or near laundry facilities, on which to store laundry supplies. A folding counter accessible from a seated position is needed as well. A rod accessible from a seated position should be available to air dry clothing. Fold-out ironing boards can be used in rooms with more limited floor space.

### **Garage or Carport:**

Until circumstances of health prohibit the continued use of personal vehicles, no one will willingly surrender their freedom to do so. Ways to safely access, enter and leave such vehicles will need to be planned.

*In inclement weather, it's important to have a covered carport or garage, or a place like a covered drop-off. If vehicles are stored inside, it's going to take more width than is normally allocated in garages and carports, for aging residents to get into and out of them. If an accessible van and car are parked side-by-side, there must be 5 feet between them, even in a garage, to permit access into the van.*

The illustration below delineates space requirements needed for access into and around a vehicle, even when stored in a private garage.

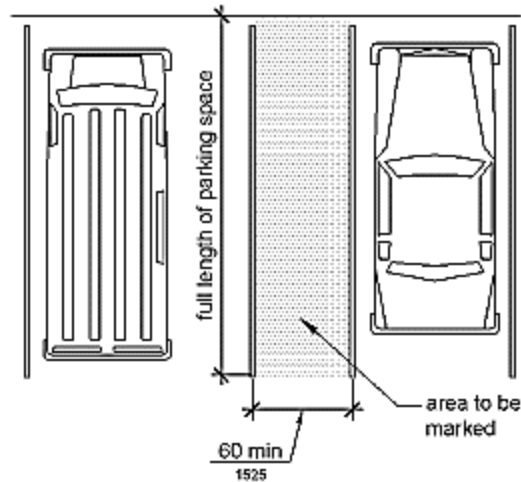

Car Parking Requirements

There may be additional changes needed to allow use of garages as aging-in-place occurs. *Raising garage door heights to eight feet instead of seven feet will provide needed clearance, if vans are needed. Some handicap transport vehicles require a nine-foot-high opening. If possible, make the entrance into the home at the same level as the garage or carport. If that is not possible in an existing home, build an accessible ramp to make up the difference in height. If there is absolutely no space for a ramp and steps must be left in place, there must be sturdy handrails installed on each side of those stairs.*

**Storage Areas:**

Certain storage areas, if able to be created in the home, can help mitigate issues in aging. Provide a closet where commonly used items like batteries, power cords, toilet paper, etc. can easily be stored and reached, even when seated. Provide a place for dedicated storage of mobility assist devices when not in use. Provide a closet with an adjustable height clothes rod to use for off-season storage. Make sure all such storage areas are wheelchair accessible.

**Hallways / Corridors:**

Changing hallways to increase accessibility will be very difficult to accomplish, but if possible, can also add many years to the ability to continue using a private residence. As can be seen from the illustrations below, and in the section on doors, it is one thing to travel down a hallway in a wheelchair and quite another to negotiate a turn.

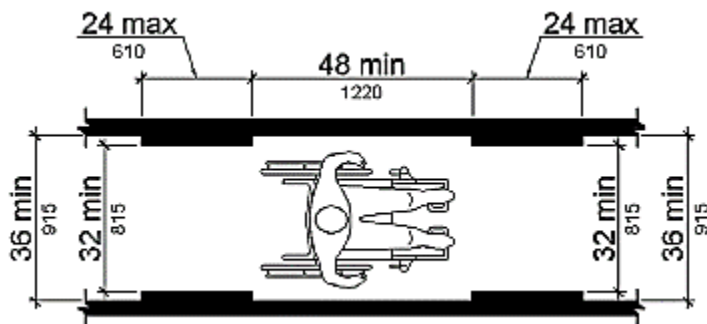

Clear Width of Accessible Route

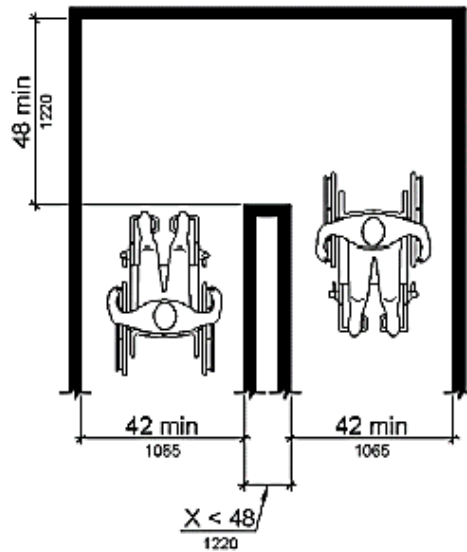

Clear Width Required at a Turn

*Recommendations are made in most manuals on accessibility, that hallways should be at least 3 feet wide and preferably wider. Most hallways in existing homes are already a minimum of 3 feet wide, so this requirement seems easy enough to meet. Turning in that hall width and entering a doorway to one side of the hall is nearly impossible. Since almost every bedroom and bathroom door in existing homes are entered sideways off a three-foot-wide hallway, it is easy to see a major problem arising.*

If a hallway absolutely needs to be widened to allow aging-in-place in a mobility assist device, keep this in mind. In almost every existing home, one wall defining a hallway will be a load-bearing wall and one will not. It is very expensive and may not be possible to relocate a wall carrying a truss or floor load above it. The other side of the hallway is easy to move, if there is a willingness to also remove and replace ceiling and floor finishes to either side of the wall. In the example included below, the simplest solution was to remove part of a closet to make a usable turn around space available. Then doors were widened, and swings altered to make the master bedroom more usable for a wheelchair, despite being slightly smaller. Note that these changes did not even provide a minimum 60" turn radius.

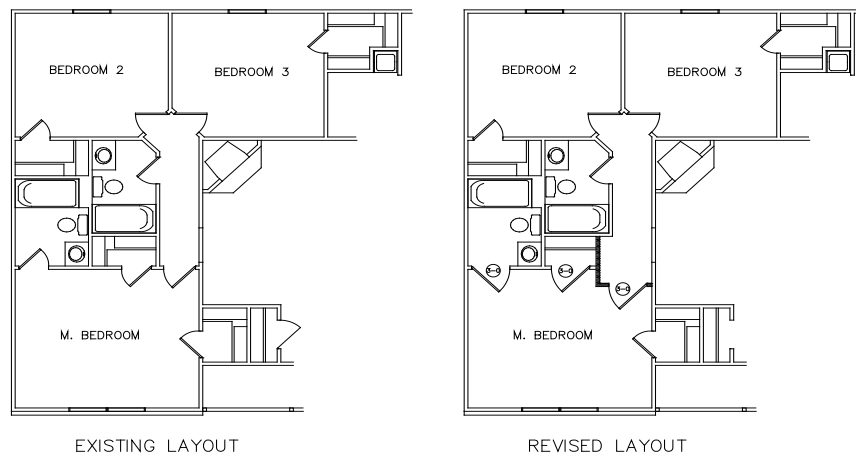

Alterations Made to Obtain Handicapped Accessibility

Ultimately, a hallway is a path from one function in the home to another. Pathways can involve halls, ramps, stairs or elevators, but each should be designed or modified to maximize safety. If wheelchairs or mobility assist devices will be needed, there should be no steps or steep inclines without options provided for an alternate route. If the path to be taken involves any length, a place or two in the route to stop, sit down and rest should be provided. Handrails on both sides of hallways give extra support when needed. *Regardless of length or needed accessories, all pathways should be well lit.*

**Stairs and Ramps:**

A pathway to enter a home, from a garage, a parking area or even from the street, may involve stairs or ramps. Illustrations below show desired clearances in some aspects of these two types of pathways.

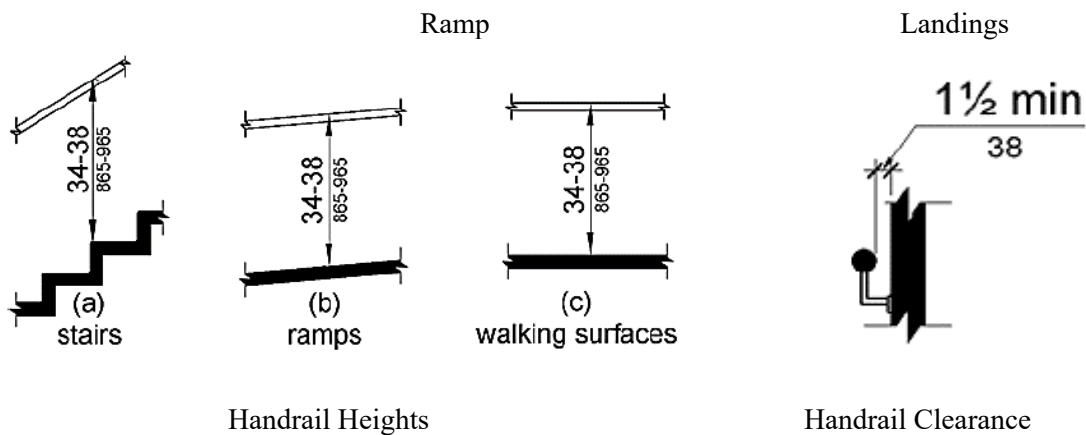
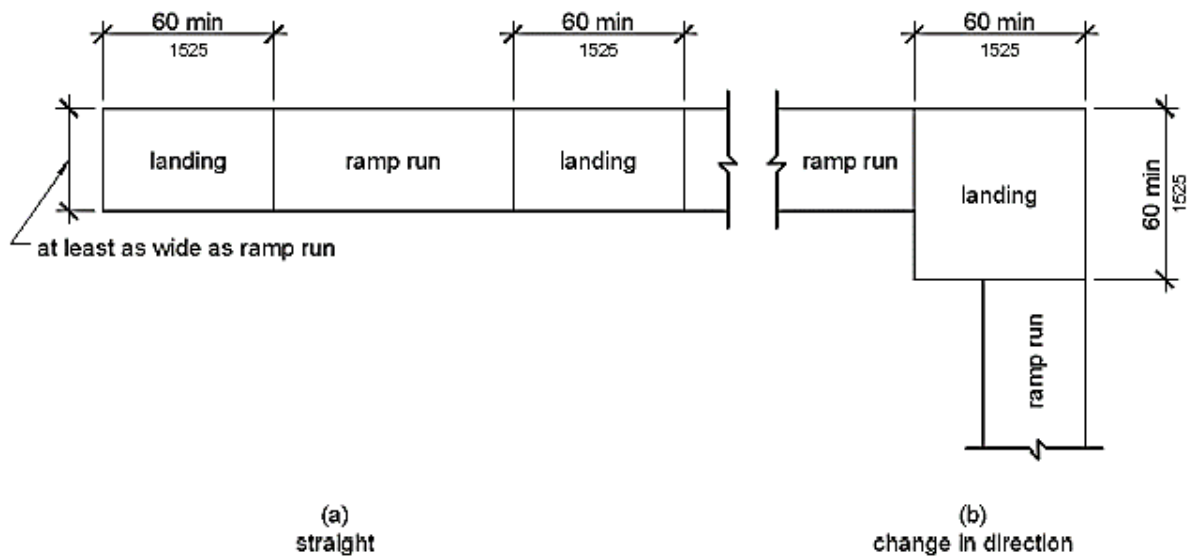

Stairs and ramps have some needs in common. *Both should have handrails on each side. These handrails should be 1 1/4" in diameter. Non-slip surfaces are a must on both. Stairs and ramps should be well lit. If level changes are minimal, and there is space to provide one, ramps are preferred over stairs.*

*When ramps are utilized, they should be no steeper than a 1" rise for each foot in length. The maximum rise for any single length of a ramp should be 30". Five-foot-wide landings are needed at entries and exits*

to ramps. *If in the open, raised curbs at least 2" high are needed on the sides of ramps to prevent wheels from slipping off.* If inside, long hallways are excellent places in which ramps can be easily added to transition between levels. But entry doors alongside ramps will need to be relocated, so they are not in the middle of a ramped hallway.

In many cases, due to space constraints, stairs will still be needed to accomplish changes in levels. This must be done, despite knowing stairs can be dangerous for people with deteriorating hips, knees, backs, vision, etc.

Measures can be taken to lessen potential harm. *Stair edges can be highlighted with contrasting colors or some other way to visually distinguish the edges of treads.* Stairs with shorter risers and fewer steps between landings are easier for the elderly to navigate. Interior stairs should have risers between 4" and 7" tall and treads should be between 11" and 14" deep. Stairs with intermediate landings that change direction can shorten the distance that will be fallen, should a slip occur. Provided landings should be the full width of a stair and at least five feet long.

Consider placing a call button near floor level at the bottom of stair runs, to call for aid in the event of an accident.

### **Additional Vertical Transportation:**

Vertical transportation is in no way considered a necessity. Other levels than the main floor of a home might simply become inaccessible, if stairs cannot be climbed and a lift cannot be installed. These can be closed off, used only as guest quarters and storage or accessed from outside the home and used as rentals. Usually the only way to regain such space for a handicapped resident is to install a chair lift or some form of an elevator.

If one is provided, an elevator should be easy to locate and easy to use. In most homes, full size elevators are not options, but rather a Limited Use elevator is installed. *Platform lifts use the least amount of space where there is no space for ramps, limited use or full-size elevators.* Most elevators, if their controls are large enough to be easily seen and used, have already been designed for use by the physically impaired. *If building a new home, even if not needed now, plan a couple closets to be located directly above one another. These should incorporate removeable floor framing so a chase can be created later for a lift or elevator, should one be needed in the future. This chase should be the minimum dimensions of the intended elevator.*

Chair lift products that can propel a seated person up and down an existing flight of stairs are available and getting better with each passing year.

Illustrations below indicate dimensions of some Limited Use Elevators, to give some idea of space that might be required on each level to be accessed.

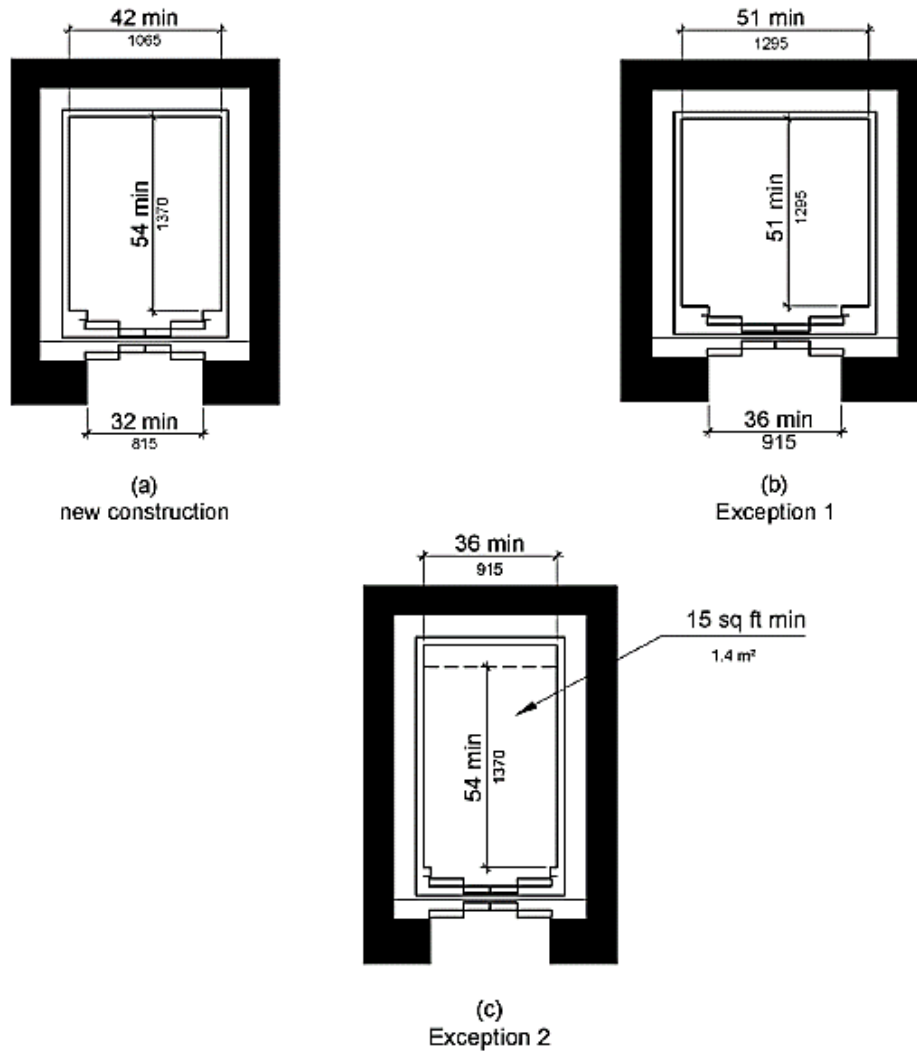

Space Requirements for Limited Use Elevators

**Finishes in General:**

‘Contrast’ is one operative word when it comes to choosing finishes for aging-in-place. *Floors and walls should be of contrasting colors, so it is easy to distinguish the different planes.* Contrasting colors for countertops, cabinets and flooring can give visual cues to those with poor eyesight looking downward, as to which surfaces are which.

The second operative word is ‘cleanability.’ Choose durable surfaces for floors, walls and countertops to make them easier to clean. Hard surface paints like epoxy or enamel are easier to clean than other choices. Curved bases and rounded transition points, where base materials meet walls and floors, are easier to clean than 90 degree corners.

**Flooring:**

Choices made regarding flooring are of special concern to aging residents. This is simply because falls are so dangerous to their future.

As is the case with bedrooms, durable, hard flooring materials like wood, vinyl and concrete are best used underfoot, where a tendency to shuffle can cause tripping and subsequent falls. The idea is to reduce situations where feet and heels can catch on a change in elevation of flooring, like the piling of a carpet. Also like in bedrooms, carpet is sometimes desired for warmth. If used, limit carpet to small areas and use only carpet with tight, short piles that are easy to clean. Use a firm pad below such carpet. The firmer the carpet and backing, the easier it to roll over and less likely it is to trip over. Many options for this type of flooring are available in commercial grade carpets. Area rugs with bound edges are sometimes considered, so they can be picked up and cleaned. But area rugs on hard surfaces can slip away and their edges, higher than surrounding flooring, still represent tripping hazards. If used, area rugs should have rubber backing and / or be secured down with double-sided tape.

Level changes present hazards as well, even level changes like transitions between hard floors and rugs or carpets. Recessed areas in concrete floors can be provided in new construction, to set area carpets down into, but this is not likely to happen in renovations. The best option is to create recessed areas with other types of raised flooring materials around the carpet, that will result in any carpet used, being flush with surrounding surfaces. *Transition strips between adjacent flooring types of different heights that do exist, will help prevent tripping. Difficulty in walking over such changes can also be overcome with the use of a cane. Diagrams below indicate suggested maximum height changes for safety.*

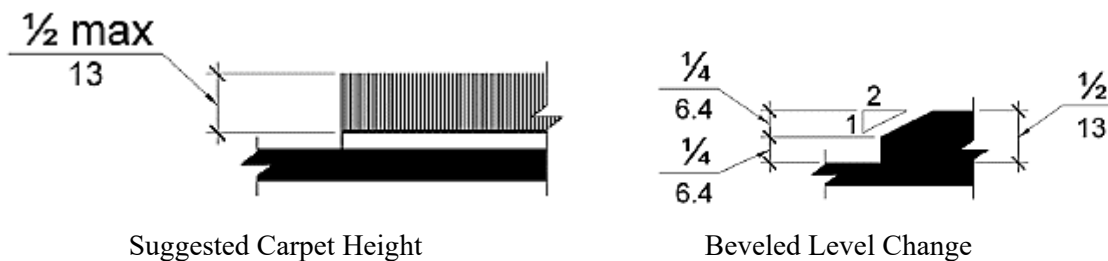

Slipping on flooring presents as great a danger as tripping over it. Get rid of any flooring that is slick, especially when wet. Use only non-skid flooring with a matte finish. If floors are to be polished, use a non-glare wax that is not slippery. Softer, more resilient flooring like cork, rubber or linoleum, is gentler on feet and can absorb some of the impact from falls. Using slippers with non-slip soles can create a measure of safety in the meantime.

Understanding problems created by flooring colors and patterns will also help minimize problems. *The color of flooring should be changed at edges where a level change is about to occur.* Darker colors with subtle patterns will somewhat hide stains. Avoid using flooring that has dark patches in a lighter field or dark lines that can be mistaken for holes or even large cracks. These can be confusing for someone with diminished vision, crossing the area. Even flooring patterns containing recognizable objects like flowers should be avoided. Residents with dementia may be confused enough to bend to try pick them up, potentially falling in the process. Bright colors with high contrast patterns can be confusing. Stick with understated, uniform patterns.

As spills and incontinence are to be anticipated, hard surfaces and carpet that can easily be cleaned will be good choices. Keep in mind that unsealed concrete will absorb liquids of any type quite readily.

The matrix below compares interior flooring materials based on care, hazards in use, and ease of mobility.

Material	Cost	Location	Ease of Care	Hazards			Ease of Mobility		
				Least Glare	Slip Resist	Trip Resist	Feet	Walker	Wheel chair
Vinyl Comp Tile	Low	Back of Home	High Maint	Least Glare	Med Slip Resist	High Trip Resist	Easy	Easy	Easy
Luxury Vinyl Tile	Mid	Common Rooms	Low Maint	Med Glare	Med Slip Resist	High Trip Resist	Easy	Medium	Medium
Sheet Vinyl	Mid	Fitness / Bathrooms	Low Maint	Med Glare	Med Slip Resist	High Trip Resist	Easy	Easy	Easy
Rubber	High	Fitness	Med Maint	Least Glare	High Slip Resist	High Trip Resist	Medium	Medium	Medium
Porcelain Ceramic Tile	Mid	Lobby Reception Bathroom Corridor	Med Maint	Med Glare	Med Slip Resist	Med Trip Resist	Medium	Hard	Medium
Carpet	Mid	Office Quiet area Corridor Living	Med Maint	Least Glare	High Slip Resist	Med Trip Resist	Hard	Hard	Hard
Wood	Mid	Lobby Dining	High Maint	Most Glare	Poor Slip Resist	Med Trip Resist	Medium	Medium	Medium

### Windows:

In a startling late-night development, I once tried to break into a home where an aged member of our church had locked herself out. Imagine my sense of triumph when I managed to work a stiff paper clip through the joining sashes of a single hung window and pulled open the lock holding it shut. Imagine my surprise, when the window still could not be opened. It turned out my elderly friend had driven nails through each side of each sash of every one of her windows, into the window jambs. With that discovery, we called a locksmith.

For any who are wondering, nailing your windows shut is a good way to ensure that if rescuers do need to enter your home for any reason, with no time to await a locksmith, your glass is going to get broken.

Better options for window security, in homes owned by the elderly, do exist. Drop down or drop in bars to limit opening operations can be effective and easily utilized security measures. But they may also conflict with local fire regulations. It's a good idea to check first before installing them.

Besides security concerns, there are other factors making windows user-friendly for aging-in-place. Keep in mind that different windows require different amounts of strength to operate. Sliders require less effort to open than single hung units. Crank out casements can be surprising difficult to operate, depending on the hardware used in their design. If windows close to the floor are also single-hung or double-hung windows, residents may find it difficult to stoop down and pull them up to allow in fresh air. While windows closer

to the floor allow better unobstructed views, they also increase the potential for falling through glass. For this reason, glazing within 18” of the floor should be of tempered glass. *Large windows to admit daylight will improve moods and offset energy bills, by making the use of supplemental lighting unnecessary during daylight hours. Lower windows down to accomplish this or use taller windows with higher head heights.*

Ease of use will play a large part in how often windows are used to allow in fresh air and cross ventilation. *Window hardware needs to be easy to operate.* Window locks should be easily operated, requiring minimal gripping or pinching. *Select windows with maintenance free exterior and interior finishes.*

### **Window Coverings:**

Window coverings obviously allow incoming levels of natural light to be adjusted by a resident. Blinds reduce views, block them out entirely, partially dampen sunlight or even redirect it up toward the ceiling to indirectly light a space. Shades, whether automatic or manual, can provide complete coverage from glare in various levels of opacity. Shades can be installed to pull from the bottom up or from the top down. Drapes are an older alternative to shades. They are also a bit more difficult to operate and bring cleanability issues with them. For any covering device, pull cords can be difficult for arthritic hands to operate. Circular chains are considerably easier to grip and manipulate.

### **Doors:**

Successful aging-in-place will always require access to any spaces needed to function independently. Very obviously, if an opening does not exist through which access can be accomplished, that space is no longer available for use to anyone using a wheelchair. For this reason, careful attention should be paid to needed access widths through openings and clearances around doorways.

#### Needed Clearance Varies by Door Type:

There are certain minimum widths needed to permit passage of a wheelchair. This is generally 32” if the wheelchair is approaching the opening straight on. *Because door widths and hinge openings use up available width, if a swinging door is used, it needs to be a minimum of 36” wide. It can also use offset door hinges. If that is not available in any opening, it will be necessary to eliminate the door, change the door type or install a new and wider door.*

All doors, regardless of type or location, occupy space when they are open. Open doors should not block further access down a hallway. Bi-fold doors opening into hallways take only half the width of a hallway than do regular swinging doors. Other door types provide more clearance through openings, when the door is open. Given the absence of a door swing to maneuver around, sliding doors provide more clearance than swinging doors. Barn doors and pocket doors allow for full use of the entire doorway width. Just as a side note, most barn doors don't completely seal an opening for purposes of sight, sound or smell. But if wall space exists for the track, they are easy to retrofit in existing homes.

Regardless of type, doors must remain easy to operate for aged hands. Unless properly maintained, most pocket doors can develop problems sliding in their tracks and in locking when closed. Pocket doors needing to be grasped while in the pocket and pulled back out, are difficult for aging residents to use. *Patio doors and screens should be easy to lock. No door should require no more than five pounds of force to open.*

The illustrations below denote clear widths required at different types of doors, when approached from different directions. Almost no existing home can provide all these clearances, but they are worth trying to obtain.

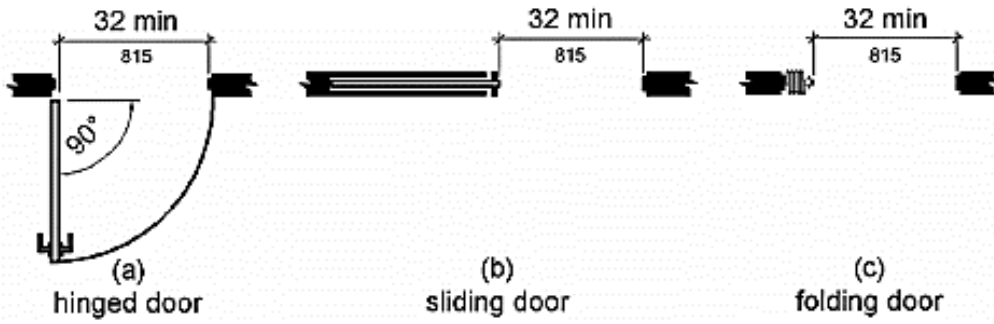

Clear Width Required at Doorways

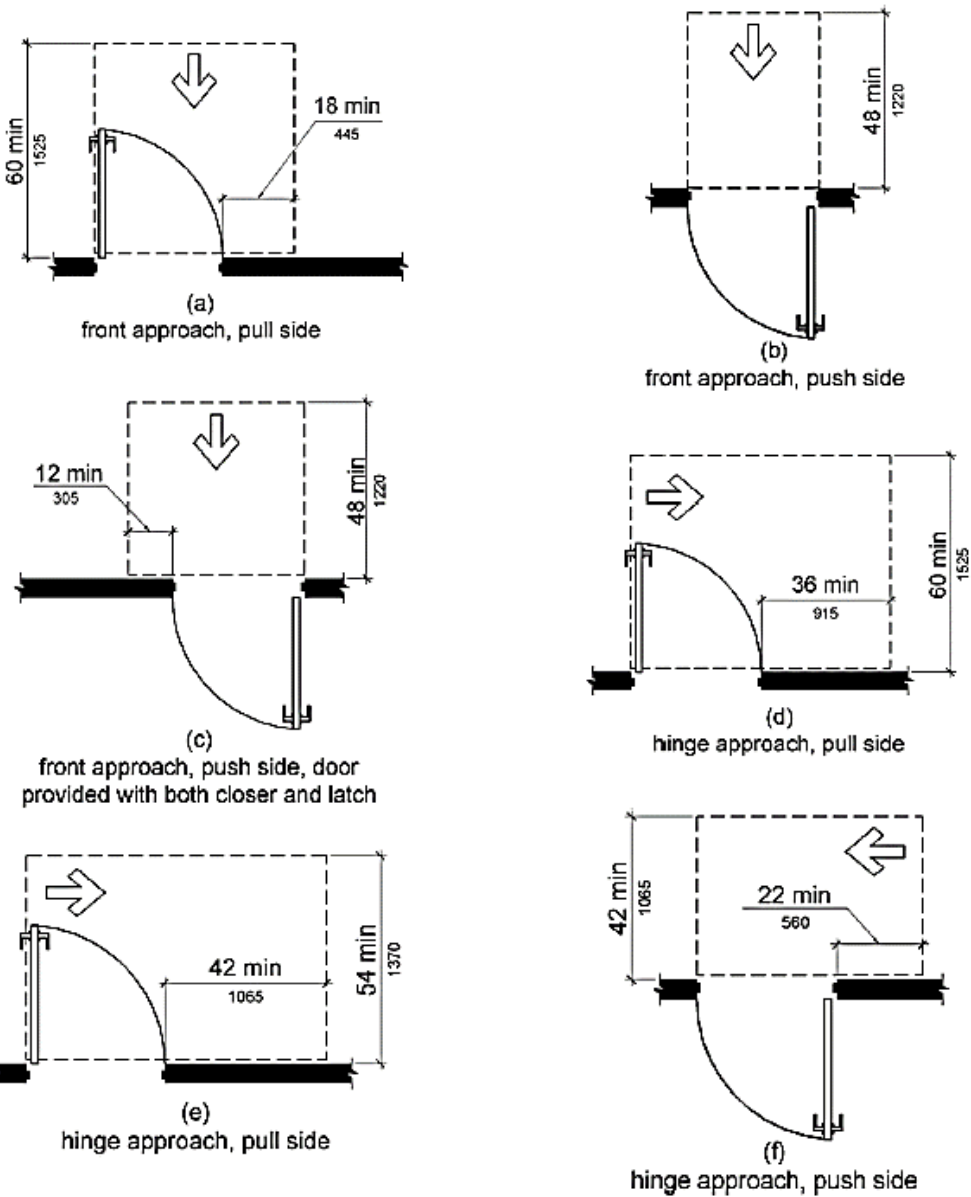

Maneuvering Clearances at Swinging Doors

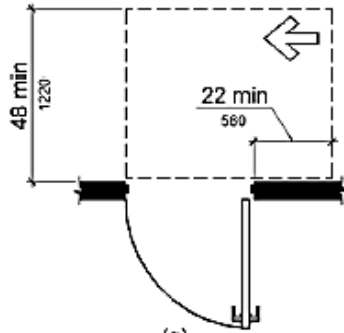

(g) hinge approach, push side, door provided with both closer and latch

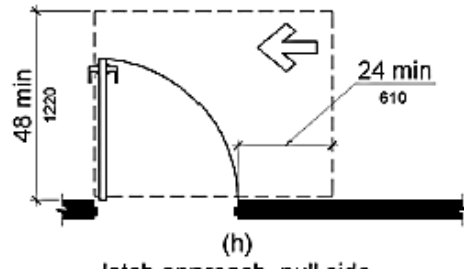

(h) latch approach, pull side

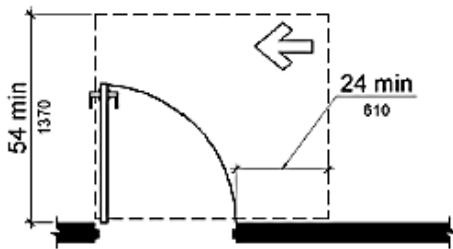

(i) latch approach, pull side, door provided with closer

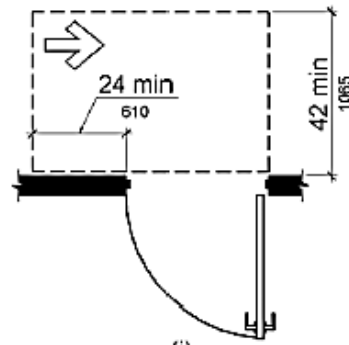

(j) latch approach, push side

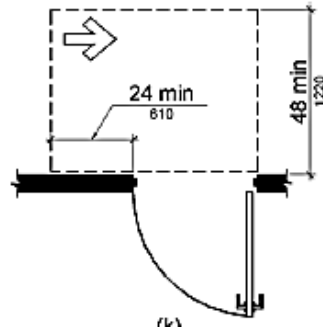

(k) latch approach, push side, door provided with closer

Additional Maneuvering Clearances at Swinging Doors

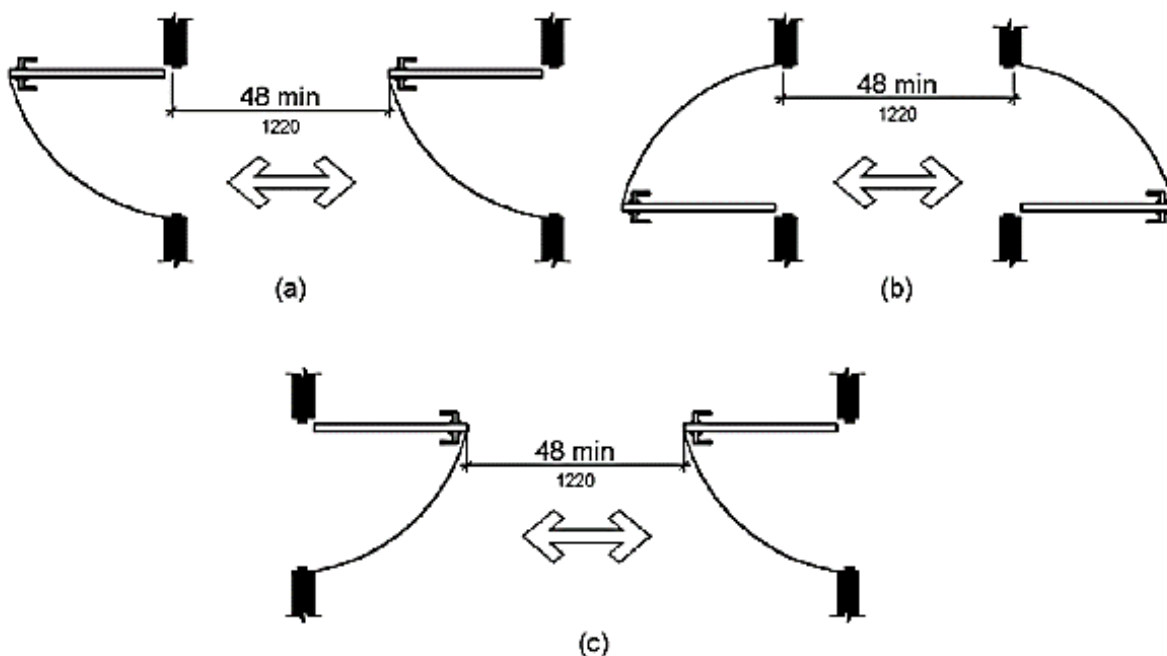

Maneuvering Clearances at Doors in Series

Hands-Free Entry:

Doors that are easy to operate will be used, while those which are not easy are better called ‘barriers.’ Doors that are automatically activated from a pressure pad or motion sensor, or that operate from a push plate, make entry while carrying packages much easier. They are also a lot more expensive than standard entry doors and seem less secure. But in buildings with multiple tenants, they are an asset. Easily operated double swinging doors, entering areas like laundry rooms, are useful when carrying baskets or using mobility assist devices.

Door Hardware:

While I have other issues creeping in with age, arthritis has thankfully not yet been an issue. But for a large part of the population, this is not true. This crippling condition makes the use of some door hardware difficult. *For this reason, and to compensate for loss of strength, door knobs should be changed out to handles. Lever handles are the easiest hardware to grip and turn.* Use of door hardware should not require pinching, a tight grip or unusual strength to turn. Doors that can be pushed open work well. Large loop pulls are good for barn doors.

Level changes from one side of a doorway to the other should be minimized or non-existent. Make sure all flooring transitions between rooms defined by doorways, have transition strips in place to help prevent tripping. *Thresholds that represent tripping hazards can be replaced with no-step or compressible rubber thresholds for safety and easier access for wheelchairs.*

The swing of a door will also need consideration when planning to age in place. Arrange doors to swing into rooms so access space leading to them is not compromised by the opening of the door. The exception to this is bathrooms. Bathroom doors should always be mounted to swing outward, since someone fallen inside will prevent an in-swinging door from being opened to help them. If a door will have a lock, it is best

to have that door swing outward so hinges can be accessed and dismantled, in the event of an emergency and a non-responsive resident inside the room.

If able to be installed without compromising safety, glazing inserted in doors can help residents with wayfinding issues, determine the use of a room before entering, as well as giving caregivers an unobtrusive glimpse inside.

### **Furnishings:**

Continuing to use a home may require some changes in furnishings. Usually this will involve finding replacements which are smaller. Clearance must be first obtained and then maintained around furniture, so mobility assist devices can be used.

Some furniture is simply no longer usable as aging occurs and should be replaced for no other reason than that. Chairs and other seating lower than 18” from the floor will be difficult to rise from. Bar stools are not very useful to the elderly either. If a seat goes back too far, the surface is too low to the ground to rise from easily or so soft the user sinks down in it, that couch or chair won’t work well for anyone with back, knee, hip or arm strength issues. *Provide sturdy chairs with armrests so users can depend on them for support while rising.*

The ongoing human desire to change our environment by rearranging furniture can still be somewhat accommodated. Lightweight furniture, so long as it is still sturdy, is easier to rearrange if a change is desired. If furniture has wheels under it to assist in movement, they should only be on the front corners and not the back. Otherwise, furniture can roll backwards when users sit down, leading to bad falls. If furnishings will be moved often, select flooring that won’t be scratched while doing so.

Furniture should also be selected to be physically friendly to users. Padded arms are a good idea for those who bruise easily. They should extend all the way to the front of the seating. If existing furniture to be retained doesn’t have them, add firm foam pads to chair and sofa seats. If there are issues of incontinence, hard surfaces or waterproofed surfaces are easier to clean than those which are absorbent. Fabric should be easy to clean. Furniture designed with openings where seats meet backs is also easier to clean when liquid gets spilled on it. Liquid won’t collect in crevices that do not exist.

### **Acoustics:**

Hearing diminishes as aging occurs, especially in the high and low ends of the frequency spectrum. Some sounds can even become painful to eardrums less elastic than before. Unwanted noise and echoes will tend to muddy the sounds residents are seeking to comprehend. Such hearing issues are very frustrating and those suffering from them, tend to isolate themselves.

Devices to assist in hearing are the best solution to this, but design choices in the home can also help somewhat. Since sound travels in a straight line, partitions can be used to block unwanted noise. Sound absorbent furniture, drapes and finishes can be used to absorb noise, reduce muddying echoes and increase clarity. Small seating areas encourage people into proximity, so conversation becomes easier.

## **ALARMS AND ALERTS**

To obtain a needed helping hand from time to time, it helps to let others know we need help.

Electronic devices can do this. *It’s a good idea to obtain a personal emergency alert system. A flashing porch light or 911 switch is another option to call for help. Direct wired alert systems can call for help*

*from relatives, and / or police, fire and EMS services, at the touch of a button. Intercoms should be installed so residents can communicate with outside visitors from the bedroom, kitchen or living areas.*

Emergencies coming from outside the home may require preparation, limited mobility makes a hasty exit difficult. Use alarm devices with both visual and audible cues, sensitive to heat, smoke and CO<sub>2</sub>, to give users time to respond. Potable water and medicines needing it, should be stored in a small refrigerator connected to a small emergency generator. That generator should also be sized to power alarm systems, the HVAC system and a few emergency lights and outlets. Enough non-perishable food should be on hand for a few days.

### **Emerging Technologies:**

New technologies can be incorporated into home care to enhance safety and create a better environment.

Some gadgets are designed for personal daily safety verification for those who live alone. Remote caregivers can monitor and engage with residents via tablets and avatars. Artificially intelligent ‘pets’ look just like real ones, but need no grooming, food or waste disposal and cannot be neglected. They do help minimize feelings of isolation. Humanoid robots are being developed to assist with household chores and socialization.

Automatic medication dispensers help prevent accidental overdoses or omissions in taking medicine. They can be set on countertops or alternately be mounted on wall shelves, on walls or in niches. GPS based systems track dementia patients via bracelet or key chain tags, without restricting their movement. The system monitors them as soon as they leave and also alerts caregivers, so they can begin monitoring the wanderer. Live streaming video cameras can help loved ones monitor elders from a distance.

### **Other Sensor Based Technologies:**

A myriad of other sensors can protect the health and safety of the aged, many by tracking movement. Motions sensors let caregivers know when a patient is up and moving. Door monitors track and record every entry and exit. If motion stops, some can signal a fall and call for help. Wrist trackers monitor steps to ascertain levels of exercise. Voice activated wrist bands can give a wandering patient directions on how to return home. *Any alert devices signaling for help should include GPS positioning, otherwise help may arrive at a residence while the device wearer is elsewhere.*

Sensors can track daily activity. Wireless, wearable sensors allow family members to stay connected. Information is constantly being sent to detect early signs of trouble, like a change in the number of trips to a bathroom. Pattern changes alert caregivers to personally verify all is well. Sensors track eating habits by registering openings of a pantry or refrigerator, with a lack of use indicating loss of interest in eating. Smart home technology verifies doors are locked at night, windows secured, appliances are turned off and so forth. Home safety sensors monitor unattended stoves and shut them off, if too hot or left on too long. Water sensors detect flooding. Temperature sensors monitor and regulate water temperatures to prevent scalding and air temperature to adjust HVAC unit thermostats.

Other sensors relay health information, with some tracking the opening of, or failure to open, a medicine cabinet door at a predetermined time. Voice activation wristbands remind residents it is time to take medications, if sensors detect they fail to do so. Bathroom sensors record how often a toilet is flushed and how long a resident is in a bathroom. Sensors can even detect a fall happening and deploy wearable air bags to minimize injuries. Under pillows, they detect and record sleep patterns, including when a user rises and lies back down. Some even detect REM patterns. Robotic devices monitor health and allow doctors to remotely complete medical examinations with aging residents at home.

## Review Questions

e. c

### HVAC SYSTEM CONCERNS

Decreased circulation increases sensitivity to temperature changes and air movement.

HVAC systems should be adapted with such users in mind and allow individual control by users. *Make sure all bedrooms have an air return, introduce fresh air into the home with an intake on the system and use CO2 detectors to maintain safe air quality.* Place supply and return vents halfway up walls, where they can be more easily adjusted than when at floor or ceiling level. Avoid installing systems with air movement strong enough to create drafts. If possible, locate possibly noisy air handlers, by or over, bathrooms or closets and not close to sleeping or living areas. Likewise, locate outside condensing units away from operable windows and from outside gathering spaces. *HVAC systems should be designed so it is very easy to change filters, even from a seated position.*

System controls should be easily understood by aging users. *Large, easy to read thermostats should be in a well-lit area, at a comfortable height. Thermostats are available that accept wireless commands, voice activation or even pre-programming, so residents won't need to be making constant changes.* Home automation systems can combine HVAC controls, lighting and security into one system, but may be beyond comprehension for some.

Residents on limited incomes value ways to lower ongoing utility bills. *Energy efficient units will often be gas-fired furnaces with air-conditioning units joined to them. Seal ductwork with mastic. Seal the house with barriers to unwanted air infiltration. Verify that exterior walls are properly insulated and remedy any which are not. If windows are being replaced, install energy efficient models with Low-E glass.* Protect ductwork from debris during renovations, so dust does not accumulate to be blown back out later.

Climate control in individual spaces can be realized without altering the climate for the entire residence. Variable speed ceiling fans increase comfort and mix air that has stratified. Make sure bathroom exhaust fans can quickly exhaust humid air and steam, quietly enough that they will not just be left off. Switch exhaust fans to operate with the lights or even an occupancy sensor. Radiant ceiling panels in bathing and dressing areas can be controlled by switches to provide immediate warmth when needed, with timers installed to turn them back off.

### ELECTRICAL CONCERNS

#### **General Lighting Concerns:**

Electrical issues primarily involve ensuring adequate lighting and enough safely placed outlets to minimize undue effort to plug in. *Simple steps are raising electrical outlets and lowering switches to increase usability. Another is to place and somewhat secure, electrical cords and phone cords along wall bases, away from foot traffic.*

*Fading eyesight may require adding lighting.* Inadequate lighting makes navigation dangerous and household tasks difficult to complete. Use general lighting at one level to keep down glare, while placing fixtures with higher light levels at task locations. Extra outlets for portable lamps helps get light where needed. Touch control lamps are easy to control without fine motor skills. Illuminate steps, ramps and flooring level changes to help eliminate falls.

Added lighting can be controlled in intensity, glare and color. *Replacing traditional bulbs with LED lamps can free up capacity on existing circuits to accommodate additional fixtures.* Added light fixtures should also not be hung so low that residents must duck to avoid them. *LED bulbs can be purchased in a color rendering index close to 100.* Full spectrum bulbs simulate the appearance of daylight. *To avoid glare, bounce some lights off ceilings and walls to provide indirect lighting. Use automatic motion sensing lights in areas like hallways, kitchens and bathrooms to ensure they are lit when in use.*

### **Lighting Control Types:**

Besides adding lights, some attention should be paid to how they are switched. *This may sound simple, but light switches should be next to the entrance of the space, so no one crosses a dark space to turn on lights. Switches and environmental controls should be between 36" and 48" above the floor. There should be a clear space of 30" by 48" in front of switches and controls.*

*The switch type will also determine how, and even if, lights are used. They should not require fine motor skills to operate. Small push buttons and slides are more difficult than simple toggle switches, large buttons and rocker switches. Illuminated light switches prevent a search in the dark for controls.* Dimming switches allow easy changes of lighting levels. Occupancy sensors to turn on lights upon entry, eliminate the need to free up a hand for use. Programmable illumination changing lighting scenarios at the touch of a button is ideal, but expensive.

A few additional changes may also prove useful. *Lighting fixtures in crucial spots should contain at least two bulbs. That way, bulbs need not be immediately changed if one fails. Audible and visual light systems should be triggered by doorbells, smoke, fire or CO2 detectors.*

In a bit of reverse reasoning, darkness can help deter dementia sufferers from wandering out of entryways. Darkened doorways are less inviting. This seems counterintuitive to needing adequate light when entering, but levels can be controlled by having brighter entry lights turned on by motion sensors.

### **Outlets:**

Outlets should be plentiful and probably closer than the code mandated spacing of 12 feet. *Cords should not be stretched across open areas as tripping hazards.* Place outlets and phone jacks in easy reach, even from wheelchairs. These can be on the front of cabinets, islands or side walls. Higher outlets are easier to access than those near the floor. Do not locate outlets near sources of water, unless they are on GFI circuits.

*Homes should be also wired for security and for computers.*

## **ADDITIONAL THOUGHTS**

### **Cost:**

Some upgrades recommended in this work cost little or nothing. Some, like upgrading to LED fixtures and bulbs, pay back more over a few years than they initially cost. For information on what many of the recommended upgrades cost, the AARP has published a guide entitled 'HomeFit Guide.'

There are numerous U.S. agencies offering assistance to make dwellings accessible for low-to-moderate income residents. In many cases, qualifications for these programs include:

- The occupant is physically disabled or has difficulty leading a normal life because of aging

- The unit under consideration is a permanent dwelling unit
- The total household income is below a stated threshold.

Weatherization Assistance programs also assist with energy-related upgrades. Priority is usually given to the aged and disabled. Utility companies are a good source of information.

Upgrading an existing home can be financially daunting. That is when prioritizing needed changes becomes critical. Renovations must be ranked in priority by cost, impact on the user and which changes are the most critical to the user's well-being. Renovations to kitchens and bathrooms seem to find their way to the top of such lists. Aging-in-place costs are sometimes best afforded when spread over time. Renovations may also need to be in stages, if the home must remain occupied during renovations.

### **Additional Obstacles:**

Besides opposition from the aging resident, and difficulties in funding needed improvements, there are at least three other parameters affecting needed changes.

### What's Behind This Wall:

Often, we won't know what we will deal with until we remove finishes on wall faces. Therefore, costs tend to creep up in renovation projects. What we intend may involve relocating plumbing or wiring, adding needed blocking or performing unforeseen alterations just to meet current codes. If lead paint, lead piping or asbestos is encountered, it will need to be removed.

### Cabinetry:

It is very unusual that existing cabinets will meet ADA recommendations for access, knee space, etc. While it is inexpensive to replace cabinet hardware for ease of use, removing the old and installing new cabinets will become costly.

### Footprint:

Working inside the footprint of existing buildings can be frustrating. It often becomes necessary to take space from one room for another. In the best cases, a bedroom will be available that can be sacrificed to make more room elsewhere. Unused dining rooms are often cannibalized to obtain additional needed space.

Walls can sometimes be eliminated to create more open space. When moving or removing walls, it will be very important to consider wiring and plumbing inside, as well as whether the wall is a primary structural component providing bearing. While it is possible to remove portions of bearing walls, it is neither easy nor inexpensive.

## **CONCLUSION**

People only rarely desire to move from their home due to aging. If they can at all manage to do so, those with homes where they raised families will want to stay for as long as humanly possible.

Since inevitable consequences of aging will otherwise force them out, it will be up to us to determine the level of effort we will exert to honor their wish to remain. Make no mistake about it. If not originally designed to be user friendly to the elderly, it will take ongoing time and expense to make changes needed to a home to accommodate them till their inevitable departure. Perhaps as much effort as it took them to adapt their homes for our arrival.

My hope is that this writing will help clarify, when and where our assistance can do the most good.

### Review Question Answers

1. If life is to be lived as fully as before, public transportation will become important when \_\_\_\_\_.
  - a. The cost of driving outweighs the benefits; Incorrect
  - b. The ability to park at typical destinations has become prohibitively expensive; Incorrect
  - c. **The task of driving has become impossible; Correct. If driving has become impossible, then a safe place to walk or having access to public transportation will become important to get to necessary basic services**
  - d. The physical condition of deteriorating roads results in too many repairs to residents' cars; Incorrect
2. \_\_\_\_\_ are used to eliminate a need for possibly painful step downs and step ups.
  - a. **Curb cuts; Correct. Safe walking routes should share some common characteristics. Curb cuts are in place to eliminate painful step downs and step ups.**
  - b. Mobility-assist devices like Segways; Incorrect
  - c. Paving materials graded absolutely flat; Incorrect
  - d. Small, lightweight personal ramps; Incorrect
3. Exterior obstacles that can prove to be hazardous to canes, walkers and mobility-assist devices are \_\_\_\_\_.
  - a. Thorn bushes; Incorrect
  - b. Curb cuts outside of the path of travel; Incorrect
  - c. **Grates with openings; Correct. No grates with openings along the way should present a hazard to canes, walkers, or even mobility-assist devices with thin wheels.**
  - d. Sloped pavement; Incorrect
4. The flared sides of a curb cut should have a maximum \_\_\_\_\_ slope.
  - a. **1:10; Correct. From the image of Curb Cuts for Ramps from Parking, flared sides have a 1:10 max slope.**
  - b. 1:12; Incorrect
  - c. 1:4; Incorrect
  - d. 1:8; Incorrect
5. Outdoor gathering areas should not be placed on \_\_\_\_\_.
  - a. Concrete with broom finishes; Incorrect
  - b. Plazas with flowering bushes; Incorrect
  - c. Surfaces known to retain heat; Incorrect
  - d. **Sloped surfaces; Correct. Proper furnishings in an outdoor space can entice residents out into fresh air, just don't create such spaces on sloped surfaces.**
6. Raised planters in gardens should not \_\_\_\_\_.
  - a. **Be too wide to reach across with a wheelchair; Correct. Raised planters in gardens should not be too wide to reach across with a wheelchair. Recesses under planters allow better access for wheelchairs.**
  - b. Contain plants that cross pollinate; Incorrect
  - c. Be made from base materials which rot; Incorrect
  - d. Be cost prohibitive to construct; Incorrect

7. As a flooring surface, pavers are considered to have \_\_\_\_\_ and \_\_\_\_\_.
- High maintenance, high glare; Incorrect
  - Medium glare, high trip resistance; Incorrect
  - Low maintenance, low trip resistance; Correct. According to the chart, pavers are considered to have low maintenance and low trip resistance.**
  - Medium maintenance, medium glare; Incorrect
8. \_\_\_\_\_ is an important criterion for choosing exterior building materials as aging occurs.
- Low levels of reflectivity; Incorrect
  - Low maintenance; Correct. Exterior materials are best if they are low maintenance, like brick or vinyl siding.**
  - Resistance to insect infestation; Incorrect
  - Colors complimentary to the neighborhood; Incorrect
9. \_\_\_\_\_ is a side benefit of opening and freeing up space.
- Clear lines of sight; Correct. A side benefit of freeing up space is creating clearer lines of sight.**
  - Space in which to place more furniture; Incorrect
  - Creation of an echo chamber; Incorrect
  - An ability to utilize a pull-out sofa; Incorrect
10. If possible, all necessary spaces in a home where aging-in-place can occur should \_\_\_\_\_.
- Be in a clear line of sight; Incorrect
  - Contain space for a hospital bed; Incorrect
  - Be available on one single level; Correct. If possible, all necessary spaces in a home should be available on one single level, with no steps between them. Even when on the same level, smooth transitions should be made between flooring of different types.**
  - Contain at least one phone jack; Incorrect
11. There should always be \_\_\_\_\_ on counters next to appliances.
- Open work space; Correct. Make sure there is space beside each appliance to set dishes down.**
  - Racks for commonly used dishes; Incorrect
  - Backdraft exhaust hoods; Incorrect
  - Medication dispensers; Incorrect
12. \_\_\_\_\_ is the item in kitchens most often needing to be replaced for reasons of safety.
- The flooring; Incorrect
  - The stove; Correct. Stoves are the appliances most needing to be changed for safety. When replacing these, avoid gas appliances. Electric or induction cooktops are much safer.**
  - The water mixing valve; Incorrect
  - The gas shut-off valve; Incorrect
13. \_\_\_\_\_ should be provided in any space where standing water can occur.
- Water absorptive flooring; Incorrect
  - A floor drain; Incorrect
  - Epoxy grout in joints; Incorrect
  - Slip resistant flooring; Correct. As with any space where water will be present, options for finishes should be carefully considered. Provide slip resistant flooring in areas where standing water can occur.**