



Architects

# Aging in Place

Course Number: AIAPDH242

4 LU|HSW

---

PO Box 449 Pewaukee, WI 53072 (888) 564-9098

[arch-support@edcet.com](mailto:arch-support@edcet.com)

# ANSWER SHEET

First Name: \_\_\_\_\_ Last Name: \_\_\_\_\_ Date: \_\_\_\_\_

Address: \_\_\_\_\_ City: \_\_\_\_\_ State: \_\_\_\_\_ ZIP: \_\_\_\_\_

Phone: \_\_\_\_\_ Email: \_\_\_\_\_

AIA #: \_\_\_\_\_

\*\* See instructions on the cover page to submit your exams and pay for your course.

## Aging in Place Final Exam

- |  |   |   |   |   |
|--|---|---|---|---|
| 1. <input type="radio"/> A <input type="radio"/> B <input type="radio"/> C <input type="radio"/> D | 7. <input type="radio"/> A <input type="radio"/> B <input type="radio"/> C <input type="radio"/> D  | 13. <input type="radio"/> A <input type="radio"/> B <input type="radio"/> C <input type="radio"/> D | 19. <input type="radio"/> A <input type="radio"/> B <input type="radio"/> C <input type="radio"/> D | 25. <input type="radio"/> A <input type="radio"/> B <input type="radio"/> C <input type="radio"/> D |
| 2. <input type="radio"/> A <input type="radio"/> B <input type="radio"/> C <input type="radio"/> D | 8. <input type="radio"/> A <input type="radio"/> B <input type="radio"/> C <input type="radio"/> D  | 14. <input type="radio"/> A <input type="radio"/> B <input type="radio"/> C <input type="radio"/> D | 20. <input type="radio"/> A <input type="radio"/> B <input type="radio"/> C <input type="radio"/> D | 26. <input type="radio"/> A <input type="radio"/> B <input type="radio"/> C <input type="radio"/> D |
| 3. <input type="radio"/> A <input type="radio"/> B <input type="radio"/> C <input type="radio"/> D | 9. <input type="radio"/> A <input type="radio"/> B <input type="radio"/> C <input type="radio"/> D  | 15. <input type="radio"/> A <input type="radio"/> B <input type="radio"/> C <input type="radio"/> D | 21. <input type="radio"/> A <input type="radio"/> B <input type="radio"/> C <input type="radio"/> D | 27. <input type="radio"/> A <input type="radio"/> B <input type="radio"/> C <input type="radio"/> D |
| 4. <input type="radio"/> A <input type="radio"/> B <input type="radio"/> C <input type="radio"/> D | 10. <input type="radio"/> A <input type="radio"/> B <input type="radio"/> C <input type="radio"/> D | 16. <input type="radio"/> A <input type="radio"/> B <input type="radio"/> C <input type="radio"/> D | 22. <input type="radio"/> A <input type="radio"/> B <input type="radio"/> C <input type="radio"/> D | 28. <input type="radio"/> A <input type="radio"/> B <input type="radio"/> C <input type="radio"/> D |
| 5. <input type="radio"/> A <input type="radio"/> B <input type="radio"/> C <input type="radio"/> D | 11. <input type="radio"/> A <input type="radio"/> B <input type="radio"/> C <input type="radio"/> D | 17. <input type="radio"/> A <input type="radio"/> B <input type="radio"/> C <input type="radio"/> D | 23. <input type="radio"/> A <input type="radio"/> B <input type="radio"/> C <input type="radio"/> D | 29. <input type="radio"/> A <input type="radio"/> B <input type="radio"/> C <input type="radio"/> D |
| 6. <input type="radio"/> A <input type="radio"/> B <input type="radio"/> C <input type="radio"/> D | 12. <input type="radio"/> A <input type="radio"/> B <input type="radio"/> C <input type="radio"/> D | 18. <input type="radio"/> A <input type="radio"/> B <input type="radio"/> C <input type="radio"/> D | 24. <input type="radio"/> A <input type="radio"/> B <input type="radio"/> C <input type="radio"/> D | 30. <input type="radio"/> A <input type="radio"/> B <input type="radio"/> C <input type="radio"/> D |

# CONTINUING EDUCATION

## for Architects

### Aging In Place: Eliminating Traps

**4 LU/HSW Hours    AIAPDH242**

#### COURSE DESCRIPTION:

In millions of homes across our country, and in the homes of people we love, existing residences are slowly but surely becoming prisons for their occupants. This happens as the aging process inevitably removes our ability to successfully navigate stairs and perform daily tasks required to live and survive independently. Societal options exist to move from private residences into congregate living facilities, where oversight and care are offered at various levels for those facing challenges. But few are interested in thus surrendering their independence. We prefer to just age-in-place.

It is possible to remain at home as physical and / or mental deterioration makes doing so more challenging. Given the amount of research that preceded establishing design standards to accommodate the handicapped, new structures can be designed which are far more user friendly to the elderly. Changes to existing homes can also be made in incremental steps as needs arise, just not as efficiently as doing so from scratch.

The knowledge and technology to enable our elders to stay at home are well established. All that is lacking are finances to do so, the time to do so, the will to do so and wide-spread dissemination of knowledge on how to do so.

The last of those issues is addressed in this work.

#### LEARNING OBJECTIVES:

- 1: A thorough understanding of physical changes that can be made in common residential structures, to make aging-in-place less physically challenging and less dangerous.
- 2: Knowledge of navigational challenges faced by the elderly outside the home, and how these can be mitigated through better design.
- 3: How to make changes in typical lighting strategies to improve living conditions for an aging population.
- 4: The proper design of exterior amenities to facilitate an increased enjoyment of nature by an aging population.
- 5: How different choices in finishes reduce or increase dangers in interior and exterior environments, typically encountered while aging-in-place.
- 6: Design choices that make common areas in multi-family housing more user friendly and safer for the aged.
- 7: Changes in normal cabinet layouts to make them easier for use by the handicapped.

## Aging In Place – Final Exam

- Limited mobility can result in \_\_\_\_\_ and \_\_\_\_\_.**
  - Failure to make health appointments, avoiding grocery shopping
  - A sedentary lifestyle, no continued interest in golf
  - Avoidance of visitors, loss of interest in family meals
  - Increased fixation on herbal supplements, replacement of a primary physician
- \_\_\_\_\_ is one of the expected phases of the aged coming to terms with a need for change.**
  - Despair
  - Eagerness to move to the next phase in life
  - A reasonable budget incorporating costs for renovations
  - Pondering
- If life is to be lived as fully as before, public transportation will become important when \_\_\_\_\_.**
  - The cost of driving outweighs the benefits
  - The ability to park at typical destinations has become prohibitively expensive
  - The task of driving has become impossible
  - The physical condition of deteriorating roads results in too many repairs to residents' cars
- How wide do sidewalks need to be before two wheelchairs can pass one another?**
  - 3 feet
  - 4 feet
  - 5 feet
  - 6 feet
- Using outside lighting focused specifically where needed effectively creates \_\_\_\_\_.**
  - Task lighting
  - Universal illumination
  - High contrast areas
  - Lower utility expenses
- Outdoor gathering areas should not be placed on \_\_\_\_\_.**
  - Concrete with broom finishes
  - Plazas with flowering bushes
  - Surfaces known to retain heat
  - Sloped surfaces
- Plants that \_\_\_\_\_ should be located well away from points of entry.**
  - Produce poisonous berries
  - Attract bees
  - Have thorns
  - Stay compact as they grow
- Raised planters in gardens should not \_\_\_\_\_.**
  - Be too wide to reach across with a wheelchair
  - Contain plants that cross pollinate
  - Be made from base materials which rot
  - Be cost prohibitive to construct
- Large maps posted outdoors are considered as a component of \_\_\_\_\_.**
  - Establishing neighborhood boundaries
  - Wayfinding
  - Marking political districts
  - Locating available real estate
- A cat box \_\_\_\_\_ makes changing kitty litter easier for the elderly**
  - With an attached scoop
  - With a lid to control pet access
  - Already inside a trash container
  - On a raised platform
- If possible, \_\_\_\_\_ should be eliminated leading to entries of homes.**
  - Doors containing keyed access
  - Wind chimes
  - Steps
  - Parking spaces
- Color, large text and large graphics are all considered useful for \_\_\_\_\_.**
  - Establishing interior decorating themes
  - Warning intruders
  - Flooring surfaces
  - Interior wayfinding
- In an age of junk mail, \_\_\_\_\_ are a useful addition to mail rooms.**
  - Recycling bins
  - Shelves for sorting
  - Receptacles for packages
  - Armed guards
- Appliances in common laundry areas should be grouped by \_\_\_\_\_.**
  - Function
  - Process
  - Shape
  - Height
- A separate area should be provided for part of the general population to \_\_\_\_\_ in comfort.**
  - Jog in loose clothing
  - Dance
  - Smoke
  - Practice yoga

16. An area considered minimal for turning around in a wheelchair has \_\_\_\_\_.
- Hard surfaces for flooring
  - A clear five-foot radius
  - Grab bars to assist in rotation
  - No raised areas within it
17. \_\_\_\_\_ is a side benefit of opening and freeing up space.
- Clear lines of sight
  - Space in which to place more furniture
  - Creation of an echo chamber
  - An ability to utilize a pull-out sofa
18. Thresholds at entries to homes should be \_\_\_\_\_ if possible.
- Flush
  - Made only of synthetics
  - Plastic
  - Water repellent
19. \_\_\_\_\_ make it possible to receive small deliveries without opening the front door.
- Dual height peepholes
  - Pre-paid delivery options
  - Staff on duty
  - Locked drop boxes
20. Frequently used items should be on shelving, no lower than \_\_\_\_\_ and no higher than \_\_\_\_\_.
- Lap height, head height
  - 24", 57.5"
  - Counter height, eye level
  - Waist level, shoulder level
21. The primary means of bathing for the elderly is \_\_\_\_\_.
- Sponge bathing
  - Entry level tub with a sealing door
  - In a shower
  - With assistance from an aide
22. The best cabinet hardware for use with arthritic hands is \_\_\_\_\_.
- Loop cabinet pulls
  - Round knobs
  - Drawers with no pulls
  - Bar pulls
23. Any place where they are in proximity to water, power outlets should be \_\_\_\_\_.
- At least 48" above the floor and 12" above a counter
  - On a GFI circuit
  - Well lit and easily located at night
  - Connected to an audible alarm
24. The minimum clear width needed in a residential hallway is \_\_\_\_\_.
- 48"
  - 32"
  - 36"
  - 39" if chair is motorized
25. The best wall to modify when creating wider hallways is one that \_\_\_\_\_.
- Is not load bearing
  - Has the fewest doors to replace
  - Has the fewest outlets on it
  - Is the furthest from the HVAC grilles
26. \_\_\_\_\_ is the minimum recommended length of landings at the ends of ramp slopes.
- 48"
  - Twice the ramp width
  - 60"
  - One and one half the ramp width
27. Drop down or drop in bars to limit opening operations of windows can conflict with \_\_\_\_\_.
- Fresh air intake
  - The use of tempered glass
  - The normal operation of locking windows
  - Local fire regulations
28. Approaching an opening straight on, \_\_\_\_\_ inches of clear opening is needed for wheelchair passage.
- 34
  - 36
  - 32
  - 31.5
29. It is a good idea to provide our elders with \_\_\_\_\_.
- Personal protection devices such as mace
  - Lessons in self-defense
  - Personal emergency alert systems
  - Maps showing clear directions home
30. \_\_\_\_\_ should be included on any alert devices used to signal for help.
- An extra battery for emergency use
  - A small flashing light
  - GPS positioning
  - Personal identification of the user

16. An area considered minimal for turning around in a wheelchair has \_\_\_\_\_.
- Hard surfaces for flooring
  - A clear five- foot radius
  - Grab bars to assist in rotation
  - No raised areas within it
17. \_\_\_\_\_ is a side benefit of opening and freeing up space.
- Clear lines of sight
  - Space in which to place more furniture
  - Creation of an echo chamber
  - An ability to utilize a pull-out sofa
18. Thresholds at entries to homes should be \_\_\_\_\_ if possible.
- Flush
  - Made only of synthetics
  - Plastic
  - Water repellant
19. \_\_\_\_\_ make it possible to receive small deliveries without opening the front door.
- Dual height peepholes
  - Pre-paid delivery options
  - Staff on duty
  - Locked drop boxes
20. Frequently used items should be on shelving, no lower than \_\_\_\_\_ and no higher than \_\_\_\_\_.
- Lap height, head height
  - 24", 57.5"
  - Counter height, eye level
  - Waist level, shoulder level
21. The primary means of bathing for the elderly is \_\_\_\_\_.
- Sponge bathing
  - Entry level tub with a sealing door
  - In a shower
  - With assistance from an aide
22. The best cabinet hardware for use with arthritic hands is \_\_\_\_\_.
- Loop cabinet pulls
  - Round knobs
  - Drawers with no pulls
  - Bar pulls
23. Any place where they are in proximity to water, power outlets should be \_\_\_\_\_.
- At least 48" above the floor and 12" above a counter
  - On a GFI circuit
  - Well lit and easily located at night
  - Connected to an audible alarm
24. The minimum clear width needed in a residential hallway is \_\_\_\_\_.
- 48"
  - 32"
  - 36"
  - 39" if chair is motorized
25. The best wall to modify when creating wider hallways is one that \_\_\_\_\_.
- Is not load bearing
  - Has the fewest doors to replace
  - Has the fewest outlets on it
  - Is the furthest from the HVAC grilles
26. \_\_\_\_\_ is the minimum recommended length of landings at the ends of ramp slopes.
- 48"
  - Twice the ramp width
  - 60"
  - One and one half the ramp width
27. Drop down or drop in bars to limit opening operations of windows can conflict with \_\_\_\_\_.
- Fresh air intake
  - The use of tempered glass
  - The normal operation of locking windows
  - Local fire regulations
28. Approaching an opening straight on, \_\_\_\_\_ inches of clear opening is needed for wheelchair passage.
- 34
  - 36
  - 32
  - 31.5
29. It is a good idea to provide our elders with \_\_\_\_\_.
- Personal protection devices such as mace
  - Lessons in self-defense
  - Personal emergency alert systems
  - Maps showing clear directions home
30. \_\_\_\_\_ should be included on any alert devices used to signal for help.
- An extra battery for emergency use
  - A small flashing light
  - GPS positioning
  - Personal identification of the user

# AGING IN PLACE: ELIMINATING TRAPS

## INTRODUCTION

I'll never forget the sick feeling in my stomach the first time the realization came to me. My once very active mother was making every excuse in the world not to leave the house in which I had grown up. She would not even allow me to take her to places I knew she loved. Her reasons were totally out of character and implausible. What was going on?

I will take you down the same train of thought where my thoughts flew. A year before, she had slipped on ice taking trash out from a back deck. Falling on the steps, she had broken one of her kneecaps. Given her advanced age, it was slow to heal. In the process, favoring one leg had put undue stress on the opposite side hip, which had begun to severely deteriorate. Now, though it seemed her knee had mended, she would not leave the home. And the suddenly obvious answer flashed into my mind.

My mother was afraid of her steps. Literally. The memory of the intense pain from the fall, coupled with the weakness in her hip, left her afraid and unsure of her ability to successfully climb down the front or back steps. Pain, and the fear of more pain, had made her a prisoner in her slightly elevated home.

Without saying anything, I drove to a nearby home improvement store. There I bought all the components I would need. Once back at her home, I spent the remaining hours of daylight installing sturdy railings leading down from her front porch to the walk below, and easy to grip handrails down from the back deck to the back yard.

Suddenly, my mother was once again free. But the year she spent in captivity was burned into my mind. My fault. My stupidity. I had no clue, because I had never known that kind of failure. And she was too proud to admit she was afraid or to ask for help.

I write this because my mother is not remotely an isolated case. There are millions of homes in our country where aging parents and other occupants face steps needed to exit from their homes. These are steps they no longer have confidence or strength to negotiate. They also face life with a bewildering array of technology with which they have never felt comfortable. Bathrooms have become dangerous places. Their own second floors and basements are no longer even accessible to them. They must sometimes grope their way through a fog of confusion just to accomplish daily tasks that were once mundane and second nature. All the while they remain silent, because they don't want to "be a burden" and ask for help.

Some problems they face cannot be helped. But many can, with the simple installation of equipment and hardware, or a few modest changes in routine. This writing is to

familiarize others with problems faced by our aging population and possibly ourselves, along with suggestions on how to mitigate these issues in our residences.

Because someone needs to remove the invisible bars.

## THE SCOPE OF THIS WORK

Every design or building issue dealing with the disabled or handicapped cannot be dealt with here.

Massive laws have been passed for the purpose of guiding design decisions for buildings intended for use by the disabled. Many of these focus on commercial buildings financed with taxpayer funds, institutional projects where users regularly come when facing health challenges, and multi-family housing of various types, possibly used for occupancy by the elderly.

Where published guidelines for public facilities cross building types, I will touch on them. Since pictures are worth more than words, where possible, I will include graphic illustrations of guidelines from the United States Access Board. Understanding the intent of such rules can at least open a glimpse into similar issues also faced in less public settings.

My focus here, however, will be on private residences. Millions of private homes are becoming more difficult to use as we age. Aging-in-place simply refers to the desire to stay in a familiar home as long as possible in life. According to the Center for Disease Control, it is "ability to live in one's own home and community safely, independently and comfortably, regardless of age, income or ability level." The easiest way to do that is to adapt the living facilities to changes in physical capabilities anticipated to arise. Otherwise, our beloved homes can slowly become prisons. And according to the AARP, over ninety percent of polled seniors want to stay home as they age. This obviously creates challenges for their children.

My intention with this course is to look at what can be done to make it possible to stay in our homes for as long as possible, despite the debilitating effects of advancing age. I wish to demystify what is needed to age-in-place, rather than in an institutional setting. And to hopefully do so, while not driving our children crazy with concern for us.

## PROBLEMS TO BE EXPECTED WITH AGING

We have a long history of aging, pretty much since the beginning of time. It is no longer difficult to predict what will happen in our lives and bodies as we add to our years.

Balance will become a significant issue. This problem can arise from a loss of physical strength, effects of different medications, cognitive and visual impairments. Without thinking through a strategy to prevent or at least minimize falls, an issue with balance can become a significant health

hazard. It's a really good idea to periodically determine if loved ones (or you) can safely do these:

- Climb up and down stairs with confidence
- Stand and sit down again on chairs, beds, toilets, etc.
- Get into, bathe and safely exit bathtubs and showers
- Drive and return from destinations, from a standpoint of both physical and cognitive capability
- Bend down and pick up items from the floor or lower shelves
- Easily carry items like grocery bags and laundry baskets
- Successfully use public transportation
- Keep the home and property clean
- Properly use all appliances
- Manage personal health

A consequence of deciding to stay at home, whether alone or not, is the strong possibility of home accidents. Depending on the severity of the accident and whether injuries occur, if someone falls, they may not be able to get back on their feet. Cognitive issues like dementia can lead them away, but not necessarily back home. Extended periods of solitude, especially around holidays and in periods of inclement weather, can foster feelings of depression. In the presence of confusion and absence of assistance, medication use can turn dangerous when ignored, taken in excess or inadvertently combined with other medicine. Limited mobility leads to other issues like avoiding grocery shopping or failure to make scheduled health appointments. There are also various health conditions like strokes or Parkinson's disease where the victims can simply no longer function alone.

The trick lies in making such assessments, without letting the person you love realize that you are thinking about making changes in their lives. Regardless of the peace-of-mind such changes may bring to you.

Even if your loved one will allow you to make changes, it's a very good idea to ease into them gradually. Prioritize the changes you (and they) feel will be beneficial and set a time frame to implement them. Discuss options and let the resident choose which ones will best meet their needs. Then accomplish agreed upon tasks in portions. Give those you love a chance to adapt to a few changes, before the next set is implemented.

If all that sounds like it will be easy, it won't.

## EXPECT RESISTANCE

### Don't Expect Gratitude:

Sometimes we just do what we have to do, regardless of the resistance faced. But don't expect aging loved ones to be grateful when we suggest or implement changes in their lives. Excuse me while I slip into my increasingly familiar role of an aging adult for a moment.

No one likes to change, not even us. We have set routines, set ways to do things, habits we cannot break if we tried, and even ways we've developed to do things based on many, many years of experience learning to get it right. Regardless of whether another way seems like a better choice to you, if we haven't decided on the necessity of change ourselves, it will most likely be nothing doing.

No one likes to admit they can improve or be improved, not even us. If we felt like there was a better way to accomplish something, we would already be doing it that way. What we generally don't care for, is someone younger than we are, telling us how much better they can make our lives. Especially when they are our children.

We don't really intend that anyone should decide for us, which of our possessions we will need to eliminate in order to declutter. What we own, we own for a reason. We'd rather take chances with falling than give that priceless item away. Store it in another place for a while? That's ridiculous. Why pay for storage when we can just keep storing it here?

No one likes role reversals, not even us. When we have been in charge our whole adult lives, we don't expect to have anyone dictate anything to us. We are the decision makers and problem solvers in our relationships. We have years of experience and hard-earned wisdom on our side. If we want your advice, we will ask for it.

No one likes admitting they need help, not even us. We have spent lifetimes helping others who need it. We have little interest in feeling helpless, tired, weak or damaged. Because in our minds, we are still strong, twenty-year-old problem solvers. To admit otherwise, will be to acknowledge the coming end of our time. Do we need help?

No, but thank you anyway.

### Graduated Change

The best proven approach on how to get aging loved ones to let others help, is to implement changes in phases. Really! These are based on stages and correspond with phases of the aging slowly coming to terms with the idea that, somewhere along the line, agility has been traded for wisdom.

## Phase 1 – Fairly Unaware:

At this point, while others may see problems developing, the resident does not. There is no motivation for them to live any differently than before. They won't discuss the issue, seek out information or acknowledge any need. At this point, there is no point in attempting to implement any changes.

## Phase 2 – Pondering:

The resident is becoming aware that maybe, just maybe, problems are surfacing that it might be possible to counter. Maybe something should change. This realization is often triggered by a bad event, like a fall with injuries. Now the resident is at least open to discussing options and specific solutions to the things they now perceive to be issues.

## Phase 3 – Implementing:

At this point, residents are ready to make changes and modifications. If changes are implemented gradually, resistance to them will be lessened. No more changes than are absolutely required should be made. It's not a bad idea to discuss beforehand, what trigger events should precipitate which changes. Everyone should be aware that sometimes, necessary changes in one space may involve taking room from one that is adjacent.

## Phase 4 – Maintenance:

Residents are beginning to even make changes in their behavior. Whatever will be necessary to maintain their status quo and remain at home. They realize a worsening of their situation might make that impossible. At this point, they will accept almost any changes that hold out hope. This is usually a point no one wants to reach. Winning probably wasn't worth it.

## review questions...

- 1. Illustrated guidelines for handicapped access to public facilities were published by the \_\_\_\_\_.**
  - a. National Handicapped Institute
  - b. Center for Disease Control
  - c. National Council for Aging-in-Place
  - d. United States Access Board
- 2. \_\_\_\_\_ is not one of the tests used to identify issues with balance.**
  - a. Easily carry items like grocery bags and laundry baskets
  - b. Successfully walk along the edge of a curb
  - c. Properly use all appliances
  - d. Climb up and down stairs with confidence
- 3. When suggesting changes be made for aged loved ones, don't expect to encounter \_\_\_\_\_.**
  - a. Gratitude
  - b. An offer to pay for them
  - c. Regulatory resistance
  - d. Schedules with room in them

## POTENTIAL CHANGES AHEAD

Now you've been warned, how difficult and thankless your new role might be. Nonetheless, the whole experience of an aging population occupying a living environment will be examined here. We will systematically explore areas where concerns arise in navigating our environments as we age. This will be followed by known standards, the intent behind their development and possible solutions to the problem being discussed.

*Items in italics that are underlined are basic starting points for modifications most likely to be needed.*

*Those items which are only italicized represent the next tier of changes also useful for aging-in-place.*

Those items in normal print are good ideas for various reasons, but a bit lower on priority lists created by limited time and expense.

## OUTSIDE THE HOME

Unless they don't intend to participate in life anymore, residents will sometimes need to leave their homes.

### Public Transportation:

If driving has become impossible, then access to, and an understanding of, public transportation will become important if life is to be lived as fully as before. Public transportation has the potential to be reliable, predictable transportation for aging residents to get to necessary basic services, when they are too far away to walk.

Basic services needing to be accessed can include, but not be limited to; health and wellness locations like community recreation centers and parks, medical facilities and pharmacies, social and spiritual opportunities like libraries, worship, community services and educational opportunities, as well as healthy food options like grocery stores, farmers markets, restaurants and community gardens.

Walking is the oldest method of accessing needed services outside the home. It is still a reliable method and one that brings side benefits for health if done safely and often. If residents are willing to do so, the shortest walking distance with safe and accessible walking routes should be scouted out ahead of time.

When walking is not possible due to climate conditions, or simply no longer feasible, options exist to utilize various types of public transportation. It should be easy to access these services. Wayfinding signage should be located along normal walking routes, identifying transit hubs. Make sure transit hubs are clearly identified, exactly as they are marked on available transit maps. Make sure any caregivers are familiar with public transit routes, schedules and hubs.

Public transportation stops should be welcoming places, well-lit and offering a climate-protected place to rest while waiting. If they do not fit that description, it never hurts to ask your city to upgrade public transportation stops. See if they will include a bench, a structure for shelter or shade, a clock and a place to post schedules and maps.

Utilizing cabs and ride-share services is another means to access needed services. Help residents locate a convenient place close to their home to enter taxis and shuttles. This will preferably be a spot that is safe and has no curb. Even better if there happens to be covered seating adjacent to that pickup area.

### Pick a Walking Route:

Evaluation of any walking route should include checking each step along the way. Are curb cuts in place on a chosen route to eliminate possibly painful step downs and step ups? If not, is a different route an option without adding excessive additional length? Are slopes in the route easily navigated? Steep slopes are painful to hips and knees. Is there comfortable separation or landscape barriers between the walk and fast-moving traffic? Is the path one the city maintains as snow and ice free? Are there any grates with openings along the way that could present a hazard to canes, walkers or even mobility-assist devices with thin wheels?

I mention grates because of a personal experience. Wheels from an older ten-speed bicycle are pretty much the same width as those on wheelchairs. Crossing a grate transverse to the directions of the slots presents few problems. Encountering one at night, while riding parallel to the direction of the slots, makes for an abrupt stop and road rash. The same danger exists when crossing them with wheelchairs or similar devices. The grate openings also present a tripping hazard for canes. Crossing such manhole covers is probably best avoided.

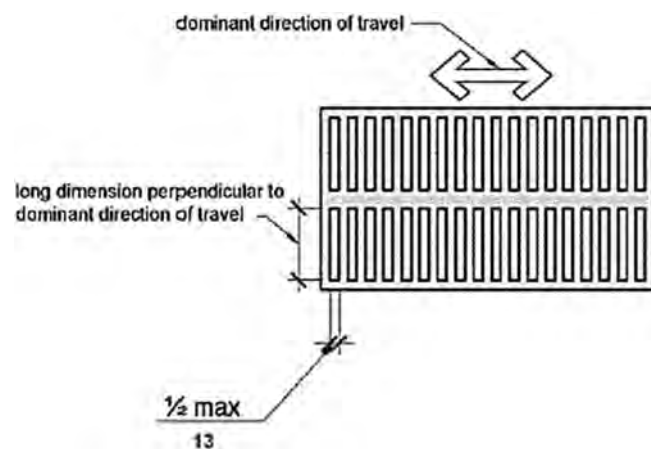

*Grate Openings with Potential Harm*

Walking paths should be safe to traverse. Paved surfaces should have slip resistance designed in, with preferably at least a stiff broom finish. Paths should be slightly sloped to one side so water falling on them will drain away. Walking surfaces should be free of defects and easy to navigate. Sidewalk cracks or broken concrete can be deadly. Transitions between paving materials should be smooth. Pathways leading into a building or transit hub shelter should be at the same plane as the floor. Crossing areas should be easy to negotiate. It's not a good idea if other potentially incompatible uses of the walkway, such as use by bicyclists, exist.

Walking paths should be easy to navigate. Simple routes between home and destination are the easiest to follow and least likely to be forgotten. The entire path should always be well lit. Gravel pathways are a poor choice, as they are difficult to walk through and impossible to roll through. Sidewalks should connect along the whole route. No detours into streets, or walking in streets, should be necessary.

The width of sidewalks controls the traffic on them, especially when wheelchairs are involved.

- 3 Feet: Single user
- 4 Feet: Two people can walk side by side
- 5 Feet: Two wheelchairs can pass
- 6 Feet: Two wheelchairs can travel together

If possible, choose a walking route where the need to navigate steps can be absolutely avoided. But if stairs are in the route, they must have handrails. They should also have rounded edges instead of metal grate surfaces that easily create injuries in falls. Slip-resistant strips in contrasting colors on the edge of each stair tread is a bonus. It is always a good idea to provide weather protection for exterior stairs, if you have that capability. Exterior stairs should have risers no greater than six inches tall and treads no less than twelve inches deep.

Walking routes should be user friendly. If intersections must be crossed, are there crosswalks? Better yet, can walk signals be triggered on demand? Acknowledging that not everyone follows traffic laws, these are nonetheless welcome measures of safety for pedestrians. If the route is of any length, are there resting places available along the way? No matter the path taken, routes should all be wheelchair accessible in terms of width, surface and slope. If a ramp must be navigated along the way, it should have handrails, especially when a fall to a lower surface or landscaping is possible. A brightly colored strip should be at the edge of any surface beside a change in plane. This will alert walkers and wheelchair users to any potential change in plane. Similar changes in color can be used to designate roadways from walkways, with yet another color used for crosswalks.

Regardless of how it is accomplished, people should have a way to get outside and reconnect to the outdoors. This

can be done in either public or private outdoor spaces. Just the ability to escape from a house that can quickly become confining, alleviates feelings of helplessness. Besides, daily access to fresh air and sunshine are welcome additions to a health regimen.

## Outdoor Car Parking

Parking for older residents should be near their homes, the closer the better. Ideally this will be attached to the home, either under a carport or in a garage. But in older established homes, it may likely be street parking. In multi-family housing or congregate living facilities, parking lots will be used. In any event, curb cuts and sloped surfaces like the one shown below are desirable to eliminate the need to step up and over level changes like curbs.

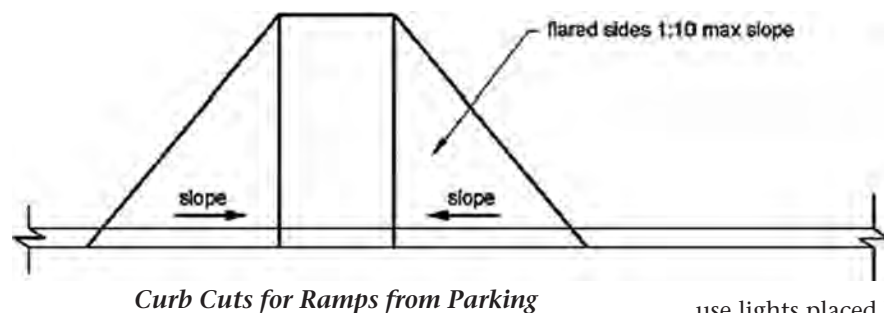

If a resident will be using public transportation like ride share services, taxis or busses, pull-up spaces are needed. These can be designed into congregate living and multi-family complexes. Some are just created by default, as when a bus or taxi pulls up alongside a curb cut and blocks traffic while passengers are loading.

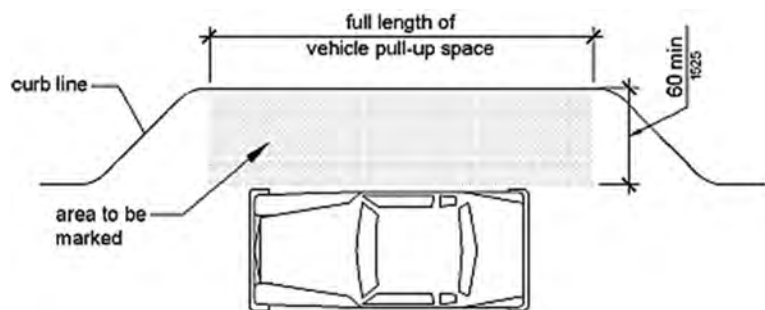

*Passenger Loading Zone*

Provided parking spaces should have plenty of space and few obstacles. When these are provided and a resident must pull into covered spaces past columns and perhaps defining walls, hanging lightweight obstacles like tennis balls, touching the windshield at the right time, provide a good cue to determine when to stop.

Regardless of whatever other entries are being accessed, parking spaces should allow easy admission to a front entry

on the main floor, preferably without navigating steps. The path from a parking area to the front door should always be paved. This sounds obvious, but residents should not have to walk significant distances in a parking lot or street to get to an access point allowing them to avoid a raised curb. If the front entry to the residence is raised higher than the parking area and walk, a sloped walk or ramp will be needed for access to the higher level. Pavement leading from parking to entry should be maintained free of cracks and settling.

## Site Lighting:

Fading eyesight is a problem suffered by a vast population. Many accidents experienced by the elderly could have been prevented by adequate lighting in areas they needed to traverse. Guidelines are readily available to establish proper light levels for various tasks, to ensure it is neither too bright nor too dim. Dim lighting making it hard to define obstacles and bright lighting creates glare. Both are undesirable.

One very effective strategy is to focus light specifically where it is needed, effectively creating task lighting outdoors. When possible, use lights placed lower and closer to the task instead of more powerful lights mounted above. Use shielded lights to direct the illumination down to the surface without creating glare in other directions. Lighting experts will also use step-down lighting levels between areas needing more and less illumination. This is because contrast between areas of low light and areas of intense light will make it difficult for eyes to adjust quickly enough. Be aware that elements in various lamp types render color differently and choose light sources / lamps that provide good color rendition. Rather than a continuous use of power, use motion activated lights in areas not often used at night, like dumpsters, walking paths, etc.

Adequate lighting is also a component of wayfinding. Lighted pathways can function as a navigation tool to direct residents back to their homes. Few people like wandering off on darker pathways, especially at night. When signage or numbers are used to identify buildings, light up that identification to keep it highly visible.

Provide lights along steps, ramps or any other change in height. Finding these level changes sight unseen, is almost always a bad surprise. In a similar vein, make sure the transition from a sidewalk to an entry is lit well enough that the entry will not be bypassed.

## Site Furnishings:

If done well and with forethought, furnishings in an outdoor space can redefine it as just another living area, enticing residents out into fresh air. When outdoor gathering areas are being designed, just don't place them

on sloped surfaces. Wheelchairs are hard to stop or start when gravity is in play. And a space large enough to accommodate a wheelchair should be at one end or the other of exterior seating. Besides wheelchair spaces, site furnishings should create places where walkers or talkers may sit, rest and catch their breath. Shade trees, canopies or shelters are used to create shade to protect those sitting from the sun, sunburn, wind or precipitation.

The ability to reconfigure any space, include outdoor gathering areas, increases the usability of that area. Moveable seating that is still heavy enough to resist scooting away from users is ideal to allow flexibility of use. Armrests on such seating are valuable to assist in rising or sitting. Seating should also have backs when possible. For easy use by the aged, seat heights for chairs should be between seventeen and nineteen inches high, with a seat depth of no more than twenty-four inches.

Other amenities can increase the attraction of outdoor spaces. If the tops of low walls enclosing planting areas are at seat height and wide enough, they can also be used for additional seating. If tables are used, they should be between twenty-eight and thirty-four inches tall with a minimum of twenty-seven inches of space below them for knees. There should be a clear floor space beside them to allow a wheelchair to approach. The outdoor space will remain far more enticing if waste receptacles are provided near outdoor seating areas.

### Landscaping:

Careful landscaping of a site is a means to create beauty. Unfortunately, it can also accidentally create hazards for the aging.

After landscaping is finished, it will still be necessary to move through a site. On a sliding scale from poor to good, pea gravel is the worst surface for mobility, followed by grass, pavers as an average surface and finally, rough concrete as the best option. Provide hard, slip-resistant surfaces on which to navigate through the outdoors. Grass and gravel are tripping hazards and difficult for mobility assist devices. Walks made from materials like flagstone are beautiful, but natural paving materials are not always uniform in size. Make sure uneven surfaces don't create tripping hazards. When using any pavers, small gaps are easier to navigate than large gaps between them. When creating them, mark the edges of walks or ramps with a contrasting color.

Some landscape materials are more user friendly than others. Avoid using metal landscape bed edging, as this is hard to see and can cut the unwary. Use bulkier materials instead. Exposed tree roots in walkway areas will obviously be a tripping hazard, but cutting and removing them will likely kill the tree. It's best just to reroute pathways so roots are not exposed or disturbed. Though it interrupts views and landscaping, fencing around property, especially in the rear of the home, can help easily disoriented users maintain a sense of privacy and stay inside safe boundaries.

Plants used should be chosen for what they will add to the user experience. Shade trees along a walkway are a welcome relief on hot days. Unless allergies come into play, flowers are always delightful. Shrubs in front of a home help soften the transition between building and land, but don't plant shrubs in such a way that they obscure sight of an entry. That can create unease that an intruder may be hiding behind them. Don't plant shrubs that grow aggressively and will need constant pruning to maintain a clean appearance. Choose plants that change color to help track seasons, smell good, don't contain or emit known allergens, are not poisonous, don't drop seed pods on walk surfaces, don't attract pooping birds and don't attract unwanted pests, animals or insects. Running away from a stinging insect isn't much of an option for aging resident, and a rapidly escalating heart rate isn't welcome either. Any plants attracting bees should be located well away from points of entry.

### Gardens:

If gardening has been a part of someone's life, suddenly not being able to do so can create a real sense of loss. But gardens present multiple dangers from maneuvering on loose soil (not even possible if a mobility assist device is needed) to issues caused by repetitive kneeling, bending and standing back up. The following elements added to garden areas can eliminate some of these risks.

Raised beds at various heights allow planting, weeding and harvesting without excessive bending. Pathways between beds can even be paved and wide enough to allow a wheelchair to turn toward the planter. Recesses under planters that are higher than knees, allow better access for those in wheelchairs. Such raised planters should not be so wide as to limit the ability to reach from a wheelchair to the other side.

If planned for ahead of time, gardening can remain enjoyable well into the aging process. If the expense is not an issue, greenhouses can enable gardening all year long. A water source and a hose for watering plants should be nearby. One possible setup is the placement of a drip hose system above planters that waters everything below when the water is turned on. Tools should be near the garden area, so obtaining and returning them is easy. A seat or bench very close to the plants, is useful for resting. Even better would be a resting spot that incorporates some method for being shaded from the sun while doing so. Given the potential for falls, weariness to set in and problems arising from heat, it is a good idea to make sure gardeners have a device on them to call for help, should that become necessary.

### Private Exterior Spaces:

Since access to public outdoor spaces might be difficult for aging owners of single-family homes, let's briefly discuss getting decked in private.

An important contributor to overall well-being is use of

an outdoor space where contact can be made with nature. Getting on and off patios and decks can be problematic as disabilities occur and problems increase. To begin with, to reduce risk of water seeping inside, existing decks and patios are often constructed one or two steps down from living levels, making them impossible for the physically impaired to use. If a deck cannot be constructed on top an existing lower patio, to create a new surface up near floor level, then a ramp down must be constructed to obtain access to that area. If a deck is constructed to bring the outside surface nearly to level, the edges of that deck will be high enough above the existing grade to constitute a hazard. Edge protection or railings should also be provided to prevent falls, even if the height difference is not enough to trigger a railing requirement by code.

Changes in levels is the problem to overcome. Ideally, interior and exterior surfaces would be at the same level, but this is very hard to accomplish. Accomplishing it would still lead to other moisture penetration issues, like melting snow alongside a sliding door flowing inside. If wheelchair access is important, a decent drop from the top of a threshold to an outside surface is best kept to a maximum of 1/2". Standard doors and French doors use a lower threshold than sliding doors. The latter often uses a threshold that is several inches high, which must then be climbed over by users. Tracks for sliding glass doors can be recessed down into floors, but this creates additional problems and pockets where water will reside, so it is rarely done. Small ramps are possible inside and outside a threshold to help transition over one with a mobility assist device.

While stepping over a threshold, or down onto a deck surface, it is easy to slip or trip. Surfaces of outdoor spaces should be non-slip, even when wet. If the surface material does not have this as a natural characteristic, coatings can be added to provide it. This type of treatment should also be applied to exterior stair treads. Whether on stairs or the deck, outdoor surfaces should be self-draining to prevent accumulation of ice. Uneven surfaces or those containing raised edges will present a problem when using canes. The matrix below compares exterior deck and patio surface materials based on care, hazards in use, and ease of mobility.

The use of outdoor spaces by the aged is often predicated on how safe it feels to do so. Decks set outside the exterior plane or face of homes are felt to be less user-friendly than porches and alcoves recessed into the mass of the building. There is something comforting about partial enclosure. When even a slightly raised surface has no railings or obstacles around the perimeter, those open edges off which a wheelchair or walker can roll make users uneasy. Perhaps this why, sometimes a view is offered in lieu of a deck. A railing across a balcony door, even with no balcony outside, will offer similar views as a balcony and give the impression of access to an outside space.

Material	Cost	Ease of Care	Hazards			Ease of Mobility		
			Least Glare	Slip Resist	Trip Resist	Feet	Walker	Wheel chair
Synthetic Decking	Mid	Med Maint	High Glare	Low Slip Resist	Low Trip Resist	Hard	Hard	Hard
Wood	Mid	High Maint	Med Glare	Med Slip Resist	Low Trip Resist	Medium	Hard	Hard
Pavers	Low	Low Maint	Least Glare	Med Slip Resist	Low Trip Resist	Medium	Hard	Medium
Concrete with a broom finish	High	Low Maint	High Glare	Med Slip Resist	High Trip Resist	Easy	Easy	Easy
Traffic Coating	Mid	Med Maint	Med Glare	Med Slip Resist	High Trip Resist	Hard	Medium	Easy

## Exterior Wayfinding:

A not so true story (I think) is told of an elderly gentleman, sitting and sobbing on a park bench. A sympathetic policeman stops to ask him what is wrong.

“I can’t go home.”

“But why? Mortgage issues? Rent problems?”

“No! I own my house outright. And it’s a beautiful comfortable home.”

The policeman frowns

“Okay? Did you get into an argument with your wife?”

“No. She still looks like the beautiful twenty-four-year-old I married forty years ago. Still as loving as ever. Still a great cook.”

Now the policeman is getting irritated.

“Well it sounds like you have every reason to go home. What’s the problem?”

“I have no idea where I live.”

No matter how many amenities you have in your home or reasons to go there, if you can’t find your way out and back home, you will quickly learn not to leave it.

This is a true story. I have a sister who once lived in a neighborhood comprised of many homes built after WW2. They were all very similar in appearance. One evening, while her husband was at work, a very drunk neighbor quietly eased in her front door, laid down on her couch and promptly went to sleep. Even without alcohol involved, correctly identifying a residence from many others that look similar, can be difficult for those with any memory issues.

Exterior identification or wayfinding markers are welcome additions to neighborhoods. Large maps posted outdoors, showing the neighborhood and nearby points of interest, are an amenity enjoyed by many. The signs used should have large text, few words, symbols and color coding. If they are used outdoors, light the signs up to be visible at night. In lieu of signage, recognizable and consistent landscape features can be used to help identify locations and features.

## Building Exterior:

What is chosen for exterior cladding materials becomes important, because many maintenance activities traditionally associated with home ownership will become increasingly difficult or impossible as aging occurs. With new homes, material choices are easy. Changes to existing homes are difficult, but if they can be done, the following criteria should be considered. *Exterior materials are best if they are low maintenance, requiring little ongoing effort to keep looking good. Examples include brick and vinyl siding.*

*Plants and shrubs around the home should also require little maintenance to keep looking good. They should be slow growing and remain compact.*

## Accommodating Pets:

Companionship of an animal, especially if that has been a constant in previous years, is an excellent way to overcome feelings of loneliness or isolation. But pet ownership does create its own set of concerns, when mobility and strength become limited.

Accessories are a key part of making pet ownership easier. *Automatic pet feeders are a great feature.* A lightweight, easy to use vacuum can be purchased to easily remove shed hair. A cat box on a raised platform or shelf makes changing kitty litter much easier. A waste receptacle with wheels or castors near a litter box is helpful as well. A raised utility tub is useful to bathe pets without stooping. A secure place to tether animals in place while bathing them can also be provided.

Be aware that when walking a large dog, if the animal decides to leave the vicinity in a hurry, despite an aged owner holding the other end of the leash, someone will get hurt. Better to have a dog run built so the animal has access to some freedom, grass and the outdoors. If an animal can be trained to go to the bathroom on a concrete portion of such a run, a hose can periodically wash the mess left behind, off onto nearby ground. A dog door leading directly into such a run is very welcome on days of inclement weather.

## Outside the Entry:

The area directly outside the main entry, for various reasons, seems to be a prime place for accidents to happen. These can be minimized by making some of the following changes. *If possible, eliminate steps leading to entries. There should be at least one handicapped accessible path into the home, involving no level changes. Keep approaches to the building free from debris, loose building materials, rocks and clutter. The entire pathway from a car to the front entry should be well lit. Secure handrails should be on each side of any steps. Paving near a residence can have radiant or hot water heating systems installed to easily melt ice that accumulates on it.*

Other changes center more on process of entering. *A minimum thirty-six-inch-wide entry door will provide the necessary thirty-two inches of clear passage through the entry. A motion sensor light should trigger when the resident approaches and be aimed to adequately light up the entry lock. The doorbell should be in an obvious accessible location.*

## review questions...

4. \_\_\_\_\_ are used to eliminate a need for possibly painful step downs and step ups.
  - a. Curb cuts
  - b. Mobility-assist devices like Segways
  - c. Paving materials graded absolutely flat
  - d. Small, lightweight personal ramps
5. Exterior obstacles that can prove to be hazardous to canes, walkers and mobility-assist devices are \_\_\_\_\_.
  - a. Thorn bushes
  - b. Curb cuts
  - c. Grates with openings
  - d. Sloped pavement
6. The flared sides of a curb cut should have a maximum \_\_\_\_\_ slope.
  - a. 1:10
  - b. 1:12
  - c. 1:4
  - d. 1:8
7. \_\_\_\_\_ is an exterior surface considered to be the worst for mobility.
  - a. Pea gravel
  - b. Concrete with a stiff broom finish
  - c. Cinder block with minor gaps between
  - d. Permeable paving
8. To permit wheelchair access, a drop from the top of a threshold to an outside surface is best kept to a maximum of \_\_\_\_\_.
  - a. 1 /4"
  - b. 7 /8"
  - c. 3 /4"
  - d. 1 /2"
9. As a flooring surface, pavers are considered to have \_\_\_\_\_ and \_\_\_\_\_.
  - a. High maintenance, high glare
  - b. Medium glare, high trip resistance
  - c. Low maintenance, low trip resistance
  - d. Medium maintenance, medium glare
10. \_\_\_\_\_ is an important criterion for choosing exterior building materials as aging occurs.
  - a. Low levels of reflectivity
  - b. Low maintenance
  - c. Resistance to insect infestation
  - d. Colors complimentary to the neighborhood

## COMMON AREAS IN MULTI-FAMILY

While living units in multi-family settings are not the primary focus of this course, they do need to be discussed, since they provide housing for many who no longer feel comfortable living alone. Layout changes are not generally possible in individual units in these buildings. But the common areas can be changed by managers. These are typically spaces for security purposes, restrooms, exercise functions, wellness needs, shared spaces for social activities, fellowship or recreational opportunities, offices for building management and services such as trash collection, mailrooms, laundry, coffee areas, libraries and kitchen / dining areas. These are all connected with horizontal travel spaces like corridors and vertical transportation like elevators, acting as streets through the community.

We will briefly examine these shared spaces, one function at a time.

### Circulation – Lobby:

A lobby should provide a core function of building security, allowing residents inside but preventing unwanted visitors from entering. This can involve intercom systems where residents buzz in expected visitors after being contacted. It can also involve keyless entry by means of proximity readers that detect authorized entry cards. Understand that every type and level of security creates its own problems for forgetful residents. But as these buildings often house a vulnerable population, some security will still be needed. That may even require a staffed front desk.

A lobby should accommodate a visitor / resident waiting and visitation area. This would be a place where residents can even conduct business with visitors without inviting them into their living spaces. Comfortable seating and tables should be in the space, with plenty of room available for maneuvering around them. Lobbies should have clusters of seating to facilitate small group gatherings and social interaction. They should have comfortable seating on which to wait, with a good line of sight to both a front desk or front office area and any outside transportation pick-up area. The front doors should be in sight and offer a clear view of approaching visitors. Having other public gathering spaces, like coffee area or lounges, encourages social interaction between residents.

The lobby should be a prominent place to obtain information. Bulletin boards can be used to post info on sales items, local events, needs of residents and so forth. Public transportation schedules and numbers to call for information can be posted here, as well as maps of surrounding areas to be used for quick reference before leaving.

Lobbies should have non-slip flooring that will not catch at heels or inhibit motion-assist devices. A grate over a recessed drain, or a walk-off mat in the front entryway, will help keep moisture from shoes off lobby floors during inclement weather. This will also reduce wear and tear on that flooring.

## Interior Wayfinding:

In many buildings, it's easy enough to get lost by just failing to pay attention or encountering any form of distraction. Dimming eyesight and fading memory will make navigation to a desired location even more difficult, especially in large buildings with many spaces that appear somewhat alike. There are ways to make successful navigation a bit more probable.

Use consistent surface treatments for similar rooms or spaces with similar functions. These will provide visual and tactile clues as to what type of space a resident is entering. Color, large text and graphics can make finding destinations a bit easier. In a multi-floor building, having public spaces on each level themed in a different color can be very helpful in instantly determining on which level you exited an elevator. Distinctive furniture in the lobby off each elevator opening also provides visual clues as to which floor has been accessed.

Signage is always helpful. Large colored graphics and signage can be even more helpful at access points to each level and entrance. Graphic icons can be used to identify common community rooms and services. Make sure there is plenty of lighting to properly illuminate wayfinding clues.

## Mail Rooms:

In most multi-tenant buildings, there will be some central place, usually near the lobby, where residents come to pick up mail that has been delivered to them. The mail area should be very visible from management offices and from the waiting area. As there will be peak times when residents come for letters, there should be plenty of room to maneuver inside such a mail pickup space.

Mailrooms will function best if hardware and equipment in them is designed with aged users in mind. All mailboxes should be easily accessed from wheelchairs. There should be shelves to set mail and packages upon. Locks and hardware on individual mailboxes should be easy to operate. Parcels needing to be mailed out should be able to be placed in a secure bin to await pickup by delivery services. Finally, in an age where residents are inundated with unwanted mailings, a recycle bin in the mailroom area is a handy place to dispose of junk mail before transporting desired letters back to a living unit.

## Administration Offices:

Spaces for building administrators or support staff are often needed in multi-tenant buildings. If they are used, administration offices should have a clear view of the front entry and have excellent visibility of the lobby. This can be accomplished with windows or even half walls open to other common areas, like mailrooms, elevators and dining areas. Signage should clearly identify the office area to both residents and visitors. Finally, seating should be provided near offices for residents or potential residents, waiting to meet with staff.

## Common Restrooms:

If residents in a multi-unit structure are expected to interact with each other in gatherings, a necessary amenity will be common restroom facilities. Those suffering from incontinence will avoid public gatherings and other opportunities for socialization, if quick access to toilet facilities is not an option. Common restrooms should be as close as possible to other amenities used as gathering spaces, to reduce time needed to get to them.

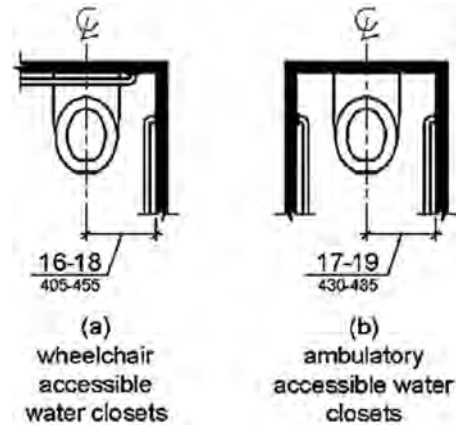

Water Closet Locations

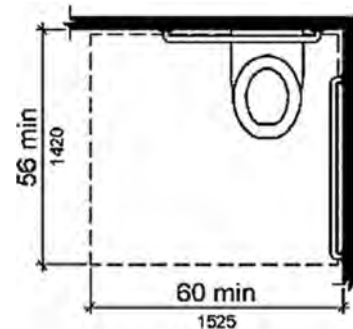

Needed Clearance at Water Closets

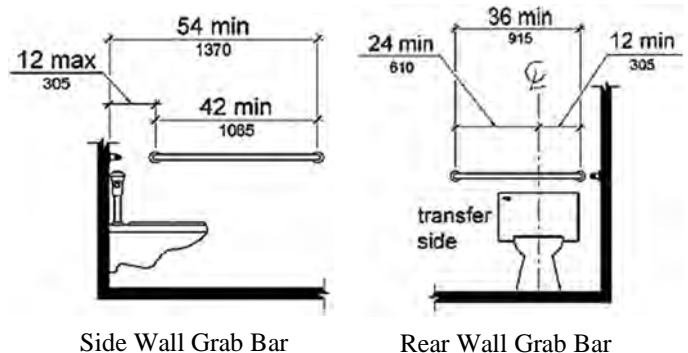

Side Wall Grab Bar

Rear Wall Grab Bar

It goes almost without saying, that restrooms for common use in buildings intended to serve the elderly, should be designed in full compliance with guidelines for handicapped use provided by the ADA. The diagrams above give a good indication of needed floor space and preferred locations of support bars placed in toilet facilities to facilitate use by the handicapped. Making several accessible, single use, unisex restrooms is often a better and more private use of space than traditional restrooms for each gender containing multiple stalls. When installing such toilet rooms, doors should be designed to swing out. This is so staff or a family member can get inside the room to help, if a user has fallen while inside. In any event, call buttons for help should also be provided inside restrooms.

### Storage Areas:

In dealing with gatherings of an aging population, there will always be items that will have been left in private rooms that residents wish they had remembered to bring with them before arriving. A common storage space will go far to eliminate the need for residents to make multiple trips back and forth to their private spaces for small things. A storage closet near the lobby can be used to store often needed items like mobility assist devices, power cords, evacuation chairs, phone chargers, etc.

On a larger scale, there will also be a need in multi-tenant buildings for longer term storage. Residents will periodically need to eliminate belongings to reduce clutter and open more floor space for maneuverability. There will be possessions carrying deep significance for the owners and they will not willingly, permanently relinquish those items. Even knowing they will likely never get to use them again, they will want them stored nearby, just in case. If storage spaces / units are provided in a common facility, on-site or nearby, that are accessible only to residents, locks and hardware should be easily understood and easily gripped. Carts, dollies or some other method of transporting goods from storage unit to living unit should be provided for use on a temporary basis.

Even a place to store seasonal decorations will be valuable to an aging population.

### Common Dining:

Eating together in a shared meal must be the absolute oldest form of communion and bonding. In multi-tenant buildings, this community function can be met in spaces ranging from full kitchens and dining rooms created for provided meals or community potlucks, to small cafes and coffee house type spaces. With nearby storage and built-in flexibility (and staff to rearrange furnishings) these can be multi-functional spaces also usable for anything from movies to crafts, card games and other social activities. When not used for eating, classes can also be conducted in these spaces for subjects like nutrition and healthier cooking. As with any other space where mobility assist devices may be used, there should be plenty of space around furniture that has been set up.

### Laundry Facilities:

Because it becomes a good place to visit with friends, another heavily used area is a community laundry room. This space should be provided in a convenient location. The entrance should be capable of being opened without the use of hands. Given that water and soap will be present in abundance, non-slip flooring is important in this room.

Machines should be arranged in a laundry for the aged, somewhat differently than those found in commercial facilities. Machines should be easily accessed without bending over. If machines are front loading, they should be raised off the floor on a platform. Machines should not be clustered by function, but rather grouped by process. They should be placed in a linear fashion by task, with a wash tub, followed by a washing machine, followed by a dryer, then by a folding table or counter and rods on which to hang warm clothes to minimize wrinkles. It should be very convenient to move clothes down the line in the process. Rods for hanging clothes should also be low enough to be accessible from wheelchairs.

Accessories should be in such rooms that are useful to the elderly. Wheeled laundry carts, incorporating storage below and a rod above, should be available to transport laundry to and from residents' rooms. Countertops for folding clothes should be at different heights to accommodate working while standing, seated or while seated in a wheelchair. These counters are best located at twenty-eight and thirty-four inches above the floor. The work should be capable of being done in a seated or standing position. Since the generation being referenced still believes in using them, pull-out ironing boards housing community irons can also be provided in this room. For all jobs, there should be task lighting over work areas, located so shadows are not cast on the work being done.

A large component of using such a space is the potential for socialization. Either in the laundry room or better yet, in an adjacent space, there should be comfortable seating and entertainment in the form of television or reading materials. That way, residents can pass time waiting on clothes and visiting with others. This is a good place to house shelves for a book exchange. Laundries are also excellent places in which to place bulletin boards for posting event information.

### Community Room:

Loneliness is an ailment far too common in an aging group. If a space to do so is provided, participating in community activities can ease feelings of loneliness and isolation.

A centrally located space can be created to house activities as diverse as watching movies or sporting events, organized discussions, playing cards, doing crafts, attending classes or just engaging in mixers or social events like dances. The key to actively utilizing such a space is making it as flexible as possible for as many uses as possible. This will likely

entail storage space adjacent to the community room, and staff to rearrange furniture as necessary. Furniture in the meeting area should be placed in such a way to provide either privacy or a choice to join small groups.

With any such space, successful use of it will depend on it being designed to be useful. There should be a lot of visibility into this space, possibly with large windows between it and hallways. Ample natural light and artificial light should be provided for users. There should be plenty of room to accommodate mobility assistance devices. Separate temperature control for this space is probably a necessity. If not already done elsewhere, this is another excellent place to house a community library.

### Fitness Center:

Exercise is by far the best and most recommended preventive measure to slow down, and sometimes reverse, deterioration of bones, tendons and muscle tissue. Common rooms for moderate exercise will be used, partly to fight deterioration, but also because needed exercise is much easier to do when meeting others to whom you make yourself accountable. But ... given tendencies toward inadvertent injuries of joints and muscles, equipment within, and recommended exercises in an area set aside for fitness, should be designed and chosen by a professional.

Walking the long way to destinations in corridors or limited climbing of stairs (if residents have the capability) are also excellent ways to obtain exercise.

### Smoking Area:

There still exists a generation that was taught that smoking cigarettes was cool and just not informed of their addictive nature until it was too late. They will be present in multi-tenant buildings and still needing to indulge that habit. Provide a separate area for their use, with no return air to the main system and a direct exhaust to the exterior. Provide entertainment and comfortable seating inside the space. That way, those who smoke can do so in comfort, without their smoke disturbing others with breathing issues.

## review questions...

11. \_\_\_\_\_ and \_\_\_\_\_ both act as streets through multi-family communities.
  - a. Laundries, ATM machines
  - b. Corridors, elevators
  - c. Concrete pavers, gravel paths
  - d. Lobbies, dining areas
  
12. Which of the following is not true of a lobby?
  - a. It's a good place to post transportation schedules
  - b. They should utilize non-slip flooring
  - c. Plants used in them should require minimal watering
  - d. They should permit small group gatherings
  
13. Which of the following is not true of common restrooms?
  - a. A lack of them discourages the incontinent from attending public gatherings
  - b. Several unisex bathrooms are preferred over those with multiple stalls
  - c. They should be in full compliance with ADA guidelines
  - d. They should contain long term storage for supplies like toilet paper
  
14. Items like mobility assist devices, power cords, evacuation chairs, phone chargers, etc. should be available for use in a closet near the \_\_\_\_\_.
  - a. Lobby
  - b. Common dining areas
  - c. Waiting area off a laundry
  - d. Staff offices
  
15. One common space used to slow down bone deterioration is \_\_\_\_\_.
  - a. A common dining area with available meals
  - b. A covered front entry open to breezes
  - c. A fitness center for moderate exercise
  - d. A home theater with well-padded seating

## INSIDE AN INDIVIDUAL HOME

While preceding subjects dealt with overall concepts applicable to exterior concerns and congregate living facilities, the remainder of this course will deal with changes inside individual homes. This is because for most of our aging population, inside their existing homes is where changes will need to be made, if they have any hope of aging-in-place.

### In General:

To better be used for aging in place, will be creating needed space in a building that is already full of a lifetime of treasures. But this will be a necessary first step. Declutter the house and try to eliminate anything no longer necessary. This will free up needed space for circulation. Remove trip hazards from paths to be taken. In the long run, any headway gained will be worth it for aging loved ones irritated at changes occurring in their lives. Easy ways to accomplish tasks like clothes washing or cooking, and practical solutions to challenges faced in bathrooms, can foster feelings of continued independence for residents aging-in-place. A second component of freeing up needed space is this. If help will be needed for certain tasks like bathing or cooking, make sure there is enough space to accommodate both the resident and an aide.

Space is the operative word in adapting a home to aging-in-place. Open plans allow for flexible use when mobility assist devices are needed. There should be multiple spaces with enough clearances in which a resident can turn around, if confined to a chair. *At a minimum, there should be a five foot by five foot turning area in the living area, kitchen, a bedroom and a bathroom. If it can be created, there should also be a 5 foot by five foot turning area at the end of a hallway. Better yet, can an extra wide hallway can be created without dead ends requiring a turn-around in tight spaces?* A side benefit of opening and freeing up space is the creation of more clear lines of sight. These allow caregivers and residents to stay in visual contact, often a source of comfort to both. An open line of sight to the exterior can also be a source of comfort to the homebound.

The following illustrations give an indication of the amounts of space that are necessary to properly navigate in a wheelchair. This needed space is the same, regardless of whether a wheelchair is being used in a public setting or in a private home.

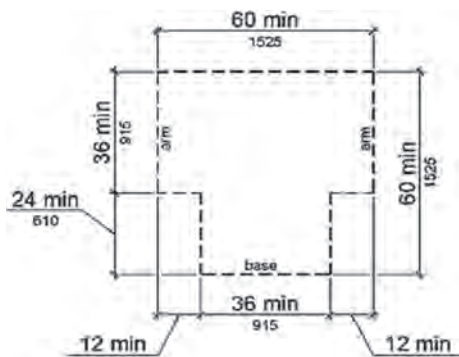

Clearances for a "T"-shaped Wheelchair Turn

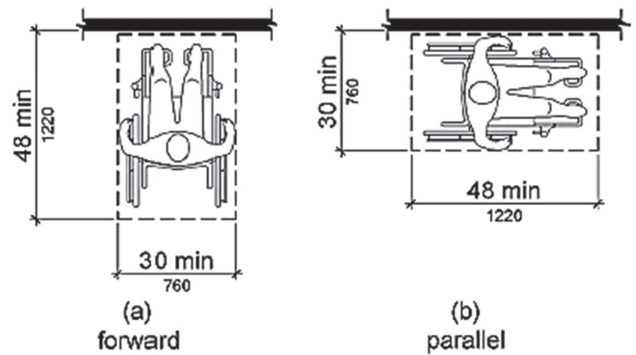

Clear Floor Spaces Needed for Maneuvering

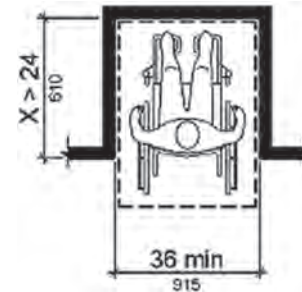

Forward Approach

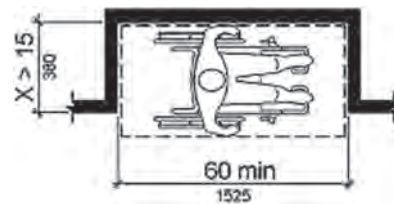

Parallel Approach

Clear Floor Spaces Needed for Maneuvering in Alcoves

Trying to make an existing home with multiple levels, totally available for use while aging-in-place, may prove to be impossible. Deteriorating knees, hips and backs may simply not safely permit climbing steps. *If possible, all necessary spaces in a home should be made available on one single level, with no steps between them.* Even when they are on the same level, smooth transitions should be possible between flooring of different types and thicknesses. Don't allow tripping hazards to remain. *If renovating with new finishes, when selecting them, try to choose finishes which result in easy-to-clean surfaces.* If possible, use low-emission finish materials in renovations, that will not emit gasses into the internal atmosphere as they continue to dry. Interior traffic flow and choices of finishes will have a large impact on how long an aging resident can safely remain in their own home.

Sometimes, it will be very helpful to minimize the amount of movement an aging resident will need to perform in daily functions. *If lines of sight are not in place, both video phones and intercom systems can make it easy to communicate between spaces without moving from one position.* Multiple phone jacks and multiple phone extensions will reduce

how far a resident must travel to answer a call. A *central vacuum system is a welcome alternative to dragging a stand-alone vacuum from space to space.*

Sooner or later, if an aging loved one wishes to remain in place in their home, they will accept that some level of compromise will be needed in how they were accustomed to living. Don't overlook the idea that a space used for one function in the past, can have that function changed to accommodate new life requirements. Living rooms can become bedrooms as easily as bedrooms can become studies, once a door is removed. Repurpose available space as needed, not based on past or traditional use.

Storage will be needed to accommodate aging-in-place. Places to store mobility assist devices out of the way until they are needed is a nice touch. Storage should be available in numerous locations and duplicate items can be made available to minimize memory issues. In this way, residents won't need to traverse much distance to get to another pair of glasses, keys, etc., should they be unable to locate the last ones they had.

### Flexible Spaces:

Sometimes, due to an inability of residents to navigate level changes, otherwise inaccessible space becomes freed up for other uses. *If a caregiver will be needed, can a separate apartment be created for that purpose and /or rented out for secondary income until needed? This is an especially pertinent question if previously accessible living space is on a second or lower level. If a little more space on a main level is available than is currently needed, designate a flexible space that can be used as a playroom for visiting children, an office, or if combined with a bathroom and kitchenette, used as a small apartment for a parent to age-in- place.*

### Foyer / Entry:

The transition between the exterior and interior of a private home is often the place most hazardous to the aging. But it doesn't need to be fraught with potential missteps. Wayfinding signage can be located inside a house entry that guides residents to the nearest transit stops. Posting copies of public transportation schedules and maps near the front door can aid in memory and in planning excursions. When looking for home, the address of the building should be in large text outside the entry. Upon arrival, a navigable surface should be provided from the pick-up area or parking area to the front entry. In multi-tenant buildings with internal corridors, level changes should not be a problem between the entry, hallway and the units either.

The passage up to a front entry should be an easy one. Paving outside should be even with or only slightly lower than flooring on the inside of the entry. Otherwise, sloped paving or a ramp may become necessary. *Thresholds at entries to the home should be flush if possible, but at most, have a drop of one-half inch to the exterior and one quarter inch to the interior. Lobbies or foyers should have devices like shelves*

*inside and out for packages, making it possible to free up hands to open the door.*

Visibility should be excellent at entryways. The door should be clearly lit at night, with light placed so the entering resident does not create shadows on the card reader or keyhole. In buildings with interior corridors, adequate lighting should be inside the hallway with readily identifiable entry doors to each unit. In either instance, a light switch for the interior of the home should be available immediately upon entering. Those seeking entry should be protected from the weather while doing so. Since fatigue is a contributing factor to falls, a bench or other means of sitting should be provided outside the front entry. Once past the door, a bench or other means of sitting should also be provided inside the front entry. A closet should be nearby where a coat can be hung. A bench to sit on and remove wet boots, and a place to drop off a wet umbrella in a foyer, will both prevent water being carried inside onto other flooring surfaces. A closet is important so removed items are not left on the floor to become tripping hazards.

The introduction of moisture into a foyer is almost certain. *For this reason, entry surfaces inside the foyer and outside an entry, should be slip-resistant.* Walk-off mats, inside and out, can be useful in reducing tracked-in moisture.

Because of their vulnerability, security is often on the mind of the aging. An audible and visual cue should alert residents when visitors or deliveries are at the door. *It should always be possible for residents to determine the identity of a visitor, without first opening the door. Dual height peepholes make this possible for standing residents or those using mobility assisted devices. Viewing panels do this as well but can create issues with security.* Regardless of whether they can be seen or not, it should be possible to communicate with visitors without first opening the door. A locked drop box that goes through the wall can be used for small deliveries such as medicine, without requiring the front door be opened to a stranger.

Hardware used to open a front entry should be easy to use. *Entry doors should have push or lever style hardware.* Lever hardware is even available that can be operated by a card reader for easy access. *If a traditional key will be used, have the lock be a contrasting color from the door, so the keyhole location is easy to discern.*

### Living Room:

The name of this room is a clue that residents will want to spend a lot of time in it, if they can. This room should have enough space to house different furniture arrangements, while still maintaining clearance around furniture to maneuver, even with mobility assist devices. If there is shelving, some should be accessible from wheelchair height. If doors are provided in front of shelving, glass in them will make it easier for forgetful residents to determine what is inside.

Choosing proper flooring will do much to enhance the usability of this space. Changes in flooring color can alert residents with poor eyesight, that they are transitioning to another space or room. It will be tempting to let carpet remain or use rugs to add a feeling of warmth. Unless they are taped to the floor or have rubber backing, area rugs may wind up being tripping hazards.

There is a built-in problem with large overstuffed furniture, that even healthy and fit users find problematic. If the seats are too deep or too low, getting in and out of a seat quickly presents a challenge. One answer to this is to eliminate as many reasons as possible to need to rise quickly. Universal remotes can be obtained with large icons that can control heating/cooling, lighting, television, security and even answer the phone. Some are programmable to perform multiple tasks with one touch of a button, to fit a different desired scenario. If such a remote is purchased and programmed, make sure its use is easily understood.

### Kitchen / Dining:

Perhaps not so much with recent generations, but cooking was a central part of the lives of our elders. Appetite somewhat diminishes with aging and eating may become less enjoyable, but not doing so will have devastating health consequences. Since the ability to leave and pick up food can also become restricted, continued easy use of a kitchen will be very important. The following are just a few considerations to make that possible.

Safety will always be a big priority in kitchen use. Make sure stoves don't have knobs that turn easily to initiate a flow of gas, when knobs are merely bumped. Induction cooktops are a great invention and worth investigating. Install smoke and carbon monoxide detectors and test them regularly.

As aging progresses, extra space may be needed in kitchens to perform ordinary tasks. If a mobility-assist device is in use, it may not be possible to approach a task location from the same direction as before. As shown below, there are code recommended clearances for kitchen tasks and in dining rooms. Meet or exceed these space requirements.

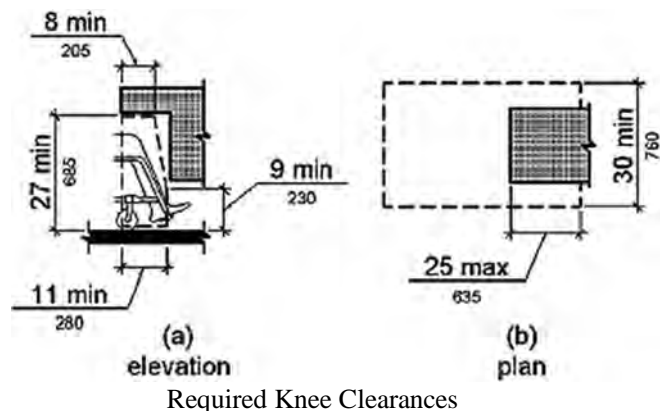

Operating space to properly use appliances is a big part of adapting kitchens to facilitate aging-in-place. It is important that doors needing to be opened, like oven and dishwasher doors, have space to do so, even when the user is in a mobility assist device. Verify there is room to approach and operate each appliance. Dishwashers should still be next to sinks for ease of plumbing and for loading. Make sure there is open work space on countertops next to appliances.

### Kitchen / Dining Cabinets:

Some thought will need to go into cabinet and countertop use. Most existing kitchens will not work well for the elderly. *Some base cabinets may need to be removable to create knee space for wheelchair users.*

Countertops may need to be changed or adjusted. *Provide support in the walls for varied heights of counters and cabinets.* Adjustable height countertops with knee space below, work great when one family member uses a mobility assist device. The top of such a work space should be no more than thirty-four inches above the floor. Lower breakfast bars that are open below, also work very well with wheelchairs. Rounded corners on countertops reduce injuries from contact. *Make sure there is space beside each appliance to set dishes down.* Use low reflective materials for countertops to reduce glare. If new counters are being ordered, *specify a colorful edge banding to define the edges of countertops, especially if the countertop and floor will be similar in color or shade.*

The following illustrations designate counter heights that are best for use with wheelchairs.

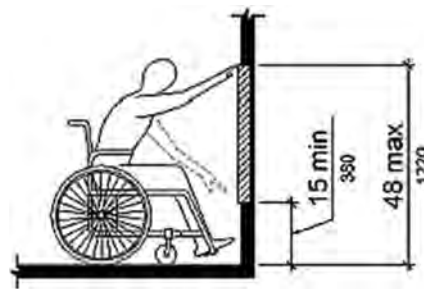

Unobstructed Forward Reach

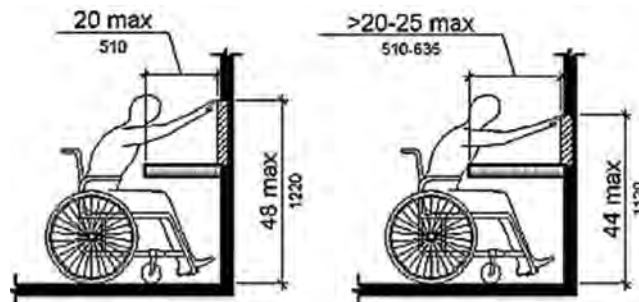

Obstructed Forward Reach

Cabinet use may also require some scrutiny. Some thoughts follow that may be useful to assess the same.

How cabinets are used, changes as the difficulty of doing so increases. Consider replacing base cabinets with drawer base cabinets. Consider lowering upper cabinets to make it easier to reach them. Consider leaving some shelving open for frequently used items. Ideally, such items should be kept no lower than waist level and no higher than shoulder level. Pull down shelving works well for seniors. Base cabinets with pull-out drawers and / or Lazy Susan's are much easier to use than ones with shelves. Pantries or pantry cabinets help eliminate the need to store food in upper cabinets. Do not install cabinets at all that must be reached by leaning over potentially hot surfaces.

Changing cabinet accessories can also make them easier to use. Soft closing cabinets are preferred by aging residents. Loop cabinet pulls are easiest for aged fingers to engage. Round knobs and doors and drawers without hardware are difficult to use. Lighting mounted under upper cabinets works well as task lighting to supplement general overhead lighting. Glass doors on cabinets, or labels on doors, help residents determine what is in them at a glance. If dealing with dementia, lockable cabinets may be needed for some medications or foods to which a resident is sensitive.

### Kitchen / Dining Appliances:

Besides establishing or maintaining work triangles, kitchen layouts for aging-in-place must include consideration of the space needed to approach appliances and task areas. Some example layouts below illustrate space needed to properly do so.

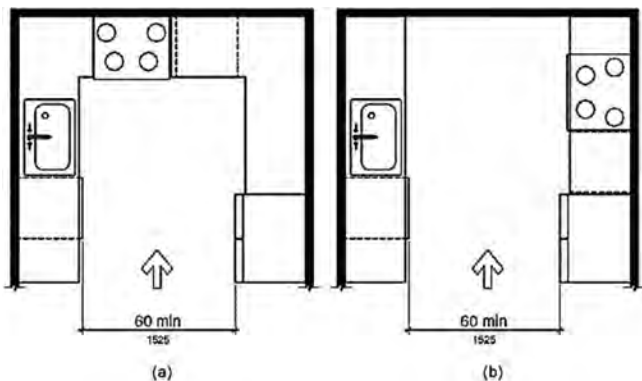
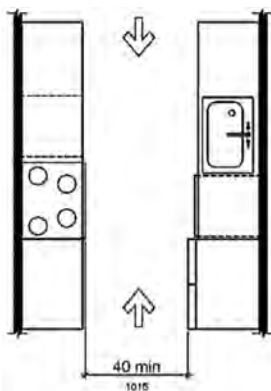

Kitchen Layouts

In addition to these, there are general guidelines for safe use of kitchens by the elderly. To begin with, all appliances should have easily understood controls. Push button controls are better than knobs needing to be twisted. There should be a clear space of thirty inches by forty-eight inches in front of each appliance, or an area in which to turn with a sixty-inch diameter. Thoughts on specific appliances follow.

Floor space should be available beside dishwashers to properly and easily load them. Raise dishwashers if needed for easier access and use ones with easy to read controls. There are even drawer dishwashers available that can be mounted under the counter, which are ideal for use whether standing or seated.

Do not mount microwaves above stoves. It is far safer to have them on countertops, mounted in a wall or in lower cabinets, especially when a resident uses a mobility assist device.

To maximize access by users in wheelchairs or scooters, side by side refrigerator / freezer combinations are a great choice. If these are not an option, a unit with the freezer drawer at the bottom is also quite usable.

Stoves are the appliance most frequently needing changed for purposes of safety. If replacing a stove or oven is an option, avoid gas appliances. Electric or better yet, induction cooktops, are much safer. If dementia is a concern, a lockable cover or kill switch can be installed, with the switch hidden somewhere it is not obvious. A downdraft feature can be incorporated to draw heat away from the user. Lights should indicate when a surface is still hot. Side swing or a wall oven are the best choices for this appliance. If using a wall mounted oven, place it at a height to minimize bending and lifting. Provide anti-tipping brackets on appliances, especially on stoves.

### Kitchen / Dining Plumbing:

Kitchen sinks may also need to be modified for continued use as residents age. Sinks should be shallow enough from front to back, that faucets can be reached from a sitting position. Faucets should use lever style handles and pull-out spray faucets. Faucets should have mixing valves incorporating anti-scald protection. Limit faucet rotation to prevent spills. Faucets with sensors can eliminate the need to use hands. Pedal controls can also be installed to make the use of faucets hands-free. If knee space is created below to allow chair access, cover or wrap any exposed piping capable of being touched, to prevent burns.

### Bathrooms:

A bathroom that works well for the elderly is a critical element in making it possible to age in place. There should be a full bath accessible on the main living level of the residence. As with kitchen use, space will be a critical component in making this possible. If wider doors are needed to properly access this room, consider a pocket door, or even the use of clear offset or expandable hinges. There should be a turnaround space inside the main bathroom, at least thirty inches by forty-eight inches, or a circle with a minimum radius of sixty inches.

If a caregiver is needed to assist in bathing, make sure there is enough space in a shower to permit that. Water controls should be accessible to the caregiver.

The diagrams below show recommended space around bathroom fixtures. Most will not be attainable in retrofits, but they set goals for which we can reach.

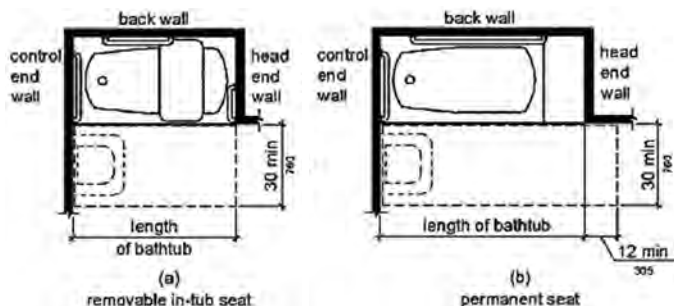

Clearances for Bathtubs

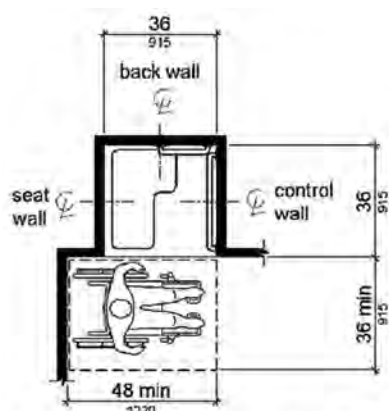

Note: inside finished dimensions measured at the center points of opposing sides

Transfer Shower Size / Clearance

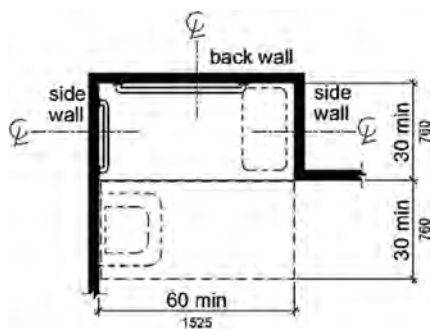

Note: inside finished dimensions measured at the center points of opposing sides

Standard Roll-in Shower Size / Clearance

In such bathrooms, there should be an accessible height toilet or a standard toilet with a raised seat. *The top of that seat should be between seventeen and nineteen inches from the seat to the floor or be height adjustable.*

Existing lavatories will most likely need replaced or modified to become more accessible. A wall mounted sink with a removeable base cabinet can be used to provide necessary knee space, by just removing the cabinet. Pedestal sinks allow easier access to chairs but will most likely not provide enough room on top for personal items. *Since pipes will be in proximity to knees, use a mixing valve with thermostat settings to prevent accidental scalding. The maximum allowable water temperature should be 120 degrees. If possible, install pressure balanced faucets. Faucets can also be pedal-controlled or have lever handles.*

As a primary means of bathing, showers for elderly use require special attention. *Stand-up showers need to be a minimum of thirty-six inches wide and are best with built-in antibacterial protection. Use a hard enclosure with a curb free door, not a curtain that will provide no help to a falling resident. Doors on tracks should not be installed on top of tubs, as they will be a major obstacle to climb for someone exiting the tub. Showers should be without curbs or at the most, have only a low threshold. This way, wheelchairs or seats can be rolled into them. There should be a fold-down seat in the shower or a standalone bath bench. Texture strips or non-skid rubber mats, added to the bottom of tubs and showers, will prevent slipping.*

Tubs are difficult for the elderly to use. Some models are available allowing entry at floor level, with a self-sealing door that can be closed before filling the tub. But these are very expensive and not often able to be purchased. *Lower height bathtubs are a compromise, as they are easier to enter and exit. These units have the disadvantage of holding less water, and still require balance, coordination and strength to use.*

*Regardless of whether in a tub, shower or combination thereof, a handheld shower spray should be used with offset controls and at least a six-foot-long hose. That will help prevent spray making it out on the floor outside the unit. Tub/shower controls should be offset from the center.*

### Bathroom Cabinets:

*Cabinetry inside existing bathrooms will likely need to be changed. Provide backing inside walls for adjustable or varying height countertops, with removeable base cabinets for when knee space is needed. If a wheelchair need be accommodated, standard vanity cabinets are not an option. Install a wall-hung sink so there will be knee space below it. The top of such a sink should be a maximum of thirty-four inches above the floor. If lower cabinets can still be used, base cabinets with pull-out drawers work better than cabinet doors with shelving behind them. If a vanity is long enough, one cabinet can be left out below to create a knee space for grooming. Where knee spaces have access to pipes, wrap plumbing to prevent burns.*

Additional changes to bathrooms can help maximize use. Rounded countertops will minimize injuries. Use countertop materials that are not very reflective, to minimize glare. *A colored stripe on the edge of counters may be needed to distinguish counter edges from the floor below.* Should there be wall mounted cabinets, provide them with glass shelves so contents are easily identified.

### Bathroom Hardware:

Aging and especially arthritic hands will appreciate further attention to details. Loop cabinet pulls work best for aging-in-place. Round knobs and doors and drawers without hardware are difficult to use. Bar pulls can catch on clothing and initiate falls. If dealing with dementia, lockable cabinets may be needed for some medications.

### Bathroom Accessories:

Installing certain accessories in bathrooms provides additional measures of safety. This is especially true of adding grab bars. *If possible, install bars at the toilet and near tubs and showers.* Provide backing inside walls for grab bars to which a resident can cling when slipping or stepping in or out of a bath or shower. These grab bars should support up to three hundred pounds. Grab bars in the shower and by the toilet should have backing behind them as well. Towel rods should never be used for support.

Seats should be available for use in showers and tubs. These can be fold-down versions, permanently built-in or just a portable stool. The best option for safety is a built-in shower seat. Some examples of seat configurations are shown below.

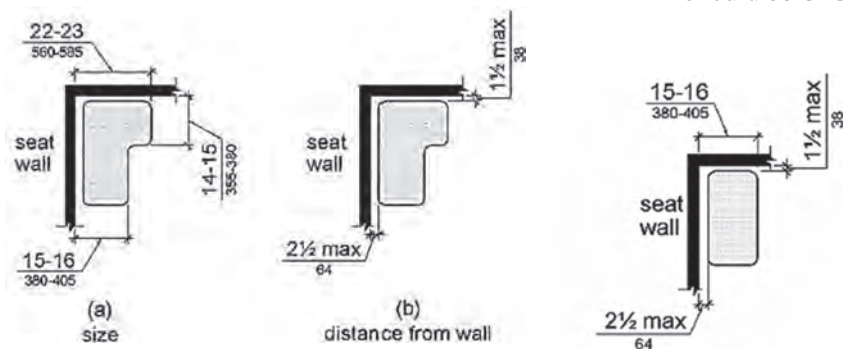

Shower Seat Examples

Some modifications are easy to accomplish. Mirrors should be hung at a height and be tall enough to accommodate someone sitting or standing. Installing mirrors that can be angled downward is one way to accomplish this. *Pick a dispenser model that makes it possible to restock toilet paper with one hand.* Place towel bars and shower robe hooks very close to exits from showers and tubs. Users should not have to stretch and risk falling off balance, to get a towel or robe. Have storage easily accessible in bathrooms for personal items and supplies for incontinence.

### Bathroom Finishes:

As with any space where water will be present, options for finishes should be carefully considered. *Provide slip resistant flooring in areas where standing water can occur.* When considering slip resistance, using smaller tiles with more grout lines creates more slip resistance than using larger tiles. *Rugs commonly used as a warm place to set feet in bathrooms, can be tripping hazards. If used, they should have rubber backing or be secured down with double-sided tape.*

Selected materials should be easy to clean, preferably without creating hard to clean corners at intersections. Epoxy grout is the best choice for resisting the build-up of contamination.

Use tiles at the base of walls that present a clear color contrast to the flooring. This will help residents clearly identify the transition points of room boundaries.

### Bathroom Power:

*Make sure there is enough light in bathrooms to perform needed tasks.* Lighted switches will help older residents easily locate the controls at night. *One light should be above the shower or tub.* Make sure mirrors are well lit on each side to eliminate shadows. Night lighting, or lights triggered by motion, also come in handy during middle of the night visits.

Placement and replacement of electrical outlets in bathrooms are dictated by safety concerns. Don't place outlets right next to sinks where they will be directly exposed to water. All outlets in proximity to wet locations should be GFCI outlets. Make sure outlets above cabinetry can still be reached from wheelchairs.

Outlets can also be placed on the face of cabinetry but must not be located where spilled water can run over their face.

Other safety concerns may dictate additional electrical changes. Have an emergency call button or cord in bathroom locations, reachable from the most likely locations for falls. Heat lamps above the shower / tub are also appreciated by those who are sensitive to cold.

### Bedrooms:

As health deteriorates and mobility decreases, more and more time will be spent in bed. That sounds like an amazing opportunity, unless someone has no choice otherwise.

Space will again be an issue in this room. There may be real difficulties obtaining this in existing homes, if a wheelchair must be used to access an existing bedroom. That will be discussed in other sections. The more cluttered the bedroom, the more difficult it will be to move from the bedroom to a nearby bathroom, or to the rest of the home. *There should be enough space in any bedroom to maneuver around the furniture,*

which at a minimum should be a bed and a dresser. At least one nightstand should also be able to be accommodated. Glasses, false teeth, needed medications and remote-control devices should be within easy reach of the bed.

The diagrams below indicate some clearances desired around a bed and in an adjacent bathroom.

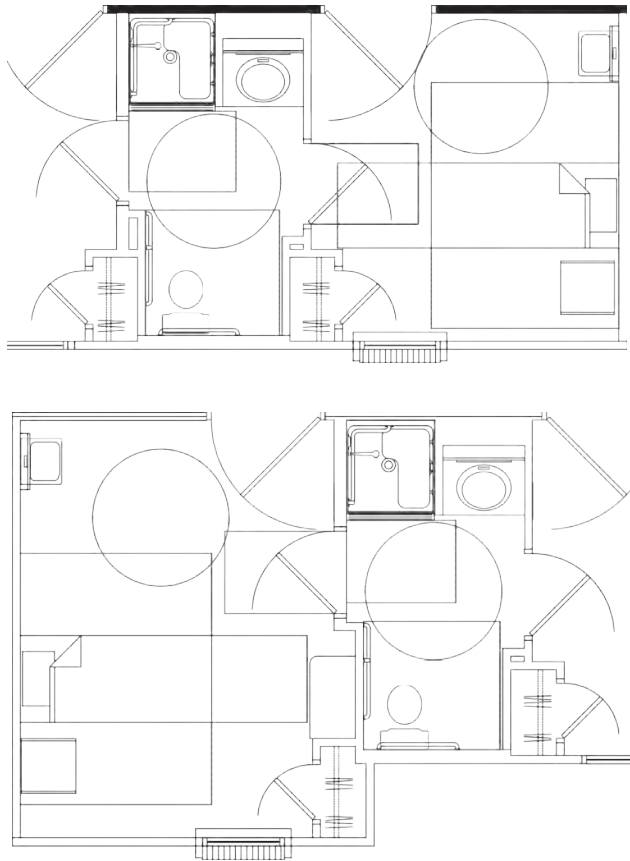

Layout of Bedroom and Adjacent Bath with Needed Clearances

Enough space should be in this room to accommodate a hospitable type bed, should one become necessary. If an existing bed will be used, *move the bed against one wall to prevent it sliding away while being sat upon or entered. If the height of the existing bed makes it difficult to use, raise it by using a thicker mattress or lower it with a thinner one as needed. Attach a handrail to a wall near the bed to support a resident when they first arise. This will give time for circulation and balance to increase before further movement.*

Power considerations for a bedroom are as follows. Two ways switches are handy for lights in bedrooms, one at the door coming in and the other next to the bed. There should be a clear line of sight or a clear path from the bed to a bathroom at a minimum. If there are no night lights to illuminate the path from bedroom to bathroom, a light switch should be near the bed to turn lights on. Phone jacks or charging stations should be next to the bed, so aging residents don't have to struggle out of bed to answer a ringing phone. The more items in the room that can

be controlled with a remote device, the better. Universal, programmable devices for this can be purchased.

### Bedroom Closets:

Existing closets may be difficult to retrofit, if the following needs cannot easily be accommodated. *Doors should be wide enough to present easy access to closets, even using a wheelchair. If a closet is a walk-in, it will also need enough clear floor space inside in which to turn such a wheelchair around.* Closets can be used both to hang clothes and store other household goods. Consider turning portions of closets into drawers to hold clothes and eliminate the need for dressers in the adjacent bedroom. *Closets should have adjustable rods and shelves. One or more clothes rods should be low enough to be accessed from a wheelchair. If possible, closets should have a light inside, with a protective cover on the light to prevent breakage.*

### Bedroom Flooring:

Consider the following when choosing finishes for bedroom floors. Wood floors are easier to maintain dust free by users suffering from allergies, but this choice will often seem stark to residents used to softer flooring. And obviously, softer flooring is a safer choice for those prone to falls. Carpet can add a feeling of warmth to the floor, but if used, it should have a low, tight pile that minimizes the possibility of tripping or stumbling. Heavy patterns on carpet can be interpreted as obstacles by aging eyes. One often used alternative to carpets is providing wood flooring, but also area rugs beside beds. *Note that loose area rugs can be a real tripping hazard and if not secured to the floor, a slipping hazard. If used, they should have rubber backing or be secured down with double-sided tape.*

### Laundry Room:

Access to, and the use of a laundry facility in the home, will need to be accommodated. *Given increasing issues with balance and strength, a laundry room located near bedrooms will reduce the distance baskets will need to be carried. A direct opening, even if only a chute between laundries and bedrooms, is even better.*

Door selection, and the space taken up by the swing of the door, are important in laundry spaces. If machines are in an alcove off a hallway or another room, bi-fold doors on a laundry closet will block part of the opening, even while open. If possible, barn doors are an option that does not result in partial blockage of laundry closet openings. *There should be turning radiuses inside actual laundry rooms and outside laundry closets opening to hallways. If a room is designated for use as a laundry area, the door must be wide enough to allow passage of mobility devices.*

Wheelchair use should be accommodated. *Seated users will find front load washers and dryers much easier to use than other models. It may be necessary to use a platform or a base from the manufacturer to raise them between twelve and fifteen inches off the floor. Easily understood controls should be on the front face of appliances.*

As with any other space, built-in accessories can make a laundry area more functional and facilitate extended use. There should be lower shelving in or near laundry facilities, on which to store laundry supplies. A folding counter accessible from a seated position is needed as well. A rod accessible from a seated position should be available to air dry clothing. Fold-out ironing boards can be used in rooms with more limited floor space.

### Garage or Carport:

Until circumstances of health prohibit the continued use of personal vehicles, no one will willingly surrender their freedom to do so. Ways to safely access, enter and leave such vehicles will need to be planned.

*In inclement weather, it's important to have a covered carport or garage, or a place to board like a covered drop-off. If vehicles are stored inside, it's going to take more width than is normally allocated in garages and carports, for aging residents to get into and out of them. If an accessible van and car are parked side-by-side, there must be five feet between them, even in a garage, to permit access into the van.*

The illustration below delineates space requirements needed for access into and around a vehicle, even when it is stored in a private garage.

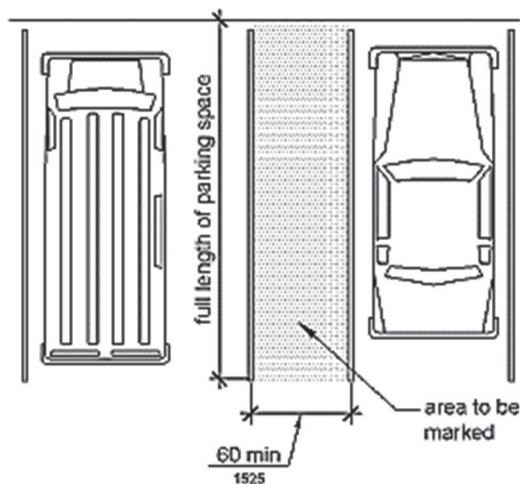

Car Parking Requirements

There will be additional changes possibly necessary to allow use of garages as aging-in-place occurs. *Raising garage door heights to eight feet instead of seven feet will provide needed clearance, if vans are needed. Some handicapped transport vehicles require a nine-foot-high opening. If possible, make the entrance into the home at the same level as the garage or carport. If that is not possible in an existing home, build an accessible ramp to make up the difference in height. If there is absolutely no space for a ramp and steps must be left in place to access a residence from the garage, there must be sturdy handrails installed on each side of those stairs.*

### Storage Areas:

Certain storage areas, if able to be created in the home, can help mitigate issues in aging. Provide a closet where commonly used items like batteries, power cords, toilet paper, etc. can easily be stored and reached, even when seated. Provide a place for dedicated storage of mobility assist devices when not in use. Provide a closet with an adjustable height clothes rod to use for off-season storage. Make sure all such storage areas are wheelchair accessible.

### Hallways / Corridors:

Changing hallways to increase accessibility will be very difficult to accomplish, but if possible, can also add many years to the ability to continue using a private residence. As can be seen from the illustrations below, and in the section on doors, it is one thing to travel down a hallway in a wheelchair and quite another to negotiate a turn.

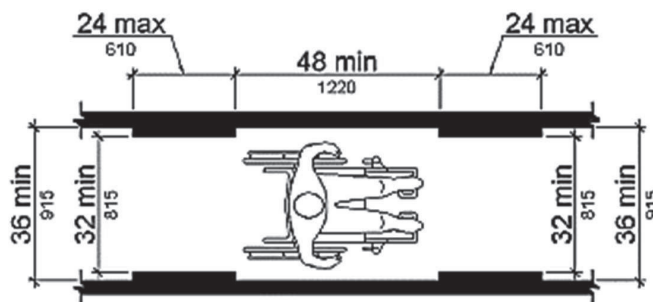

Clear Width of Accessible Route

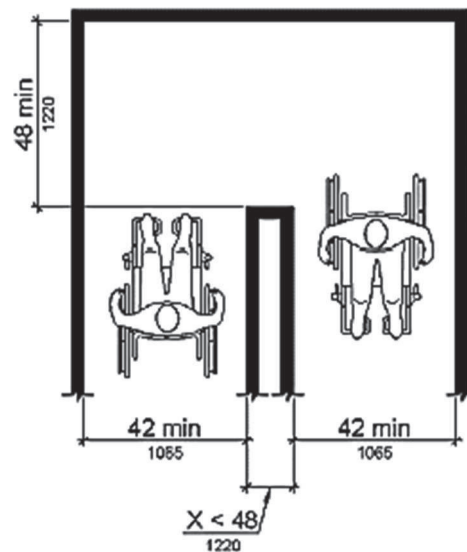

Clear Width Required at a Turn

*Recommendations are made in most manuals on accessibility, that hallways should be at least three feet wide and preferably wider. Most hallways in existing homes are already a minimum of three feet wide, so this requirement seems easy enough to meet. Turning in that hall width and entering a doorway to one side of the hall is nearly impossible. Since almost every bedroom and bathroom*

door in existing homes are entered sideways off a three-foot-wide hallway, it is easy to see a major problem arising.

If a hallway absolutely needs to be widened to allow aging-in-place in a mobility assist device, keep this in mind. In almost every existing home, one wall defining a hallway will be a load-bearing wall and one will not. It is very expensive and may not be possible to relocate a wall carrying a truss or floor load above it. The other side of the hallway is easy to move, if there is a willingness to also remove and replace ceiling and floor finishes to either side of the wall needing relocated. In the example included below, the simplest solution was to remove part of a closet to make a usable turn around space available. Then doors were widened, and the swings altered to make the master bedroom usable for a wheelchair, despite being slightly smaller. Note that these changes did not even provide a minimum 60 inch turn radius.

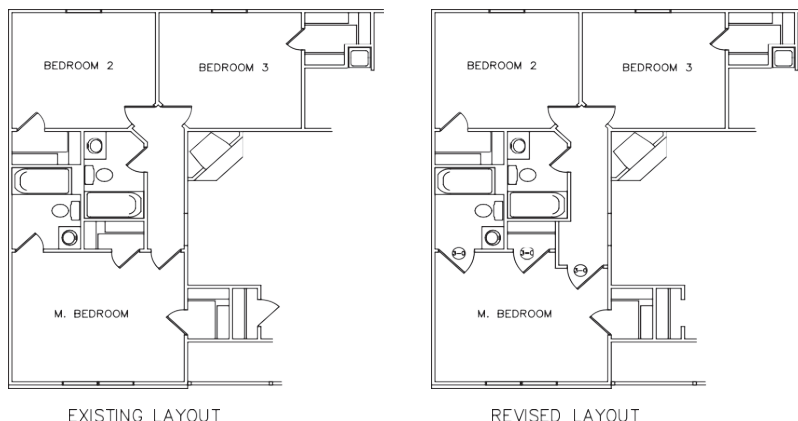

Alterations Made to Obtain Handicapped Accessibility

Ultimately, a hallway is a path from one function in the home to another. Pathways can involve halls, ramps, stairs or elevators, but each should be designed or modified to maximize safety. If wheelchairs or mobility assist devices will be needed, there should be no steps or steep inclines without options provided for an alternate route. If the path to be taken involves any length, a place or two in the route to stop, sit down and rest should be provided. Handrails on both sides of hallways give extra support when needed. *Regardless of length or needed accessories, all pathways should be well lit.*

### Stairs and Ramps:

A pathway to enter a home, from a garage, a parking area or even from the street, may involve stairs and ramps. Illustrations below show desired clearances in some aspects of these two types of pathways.

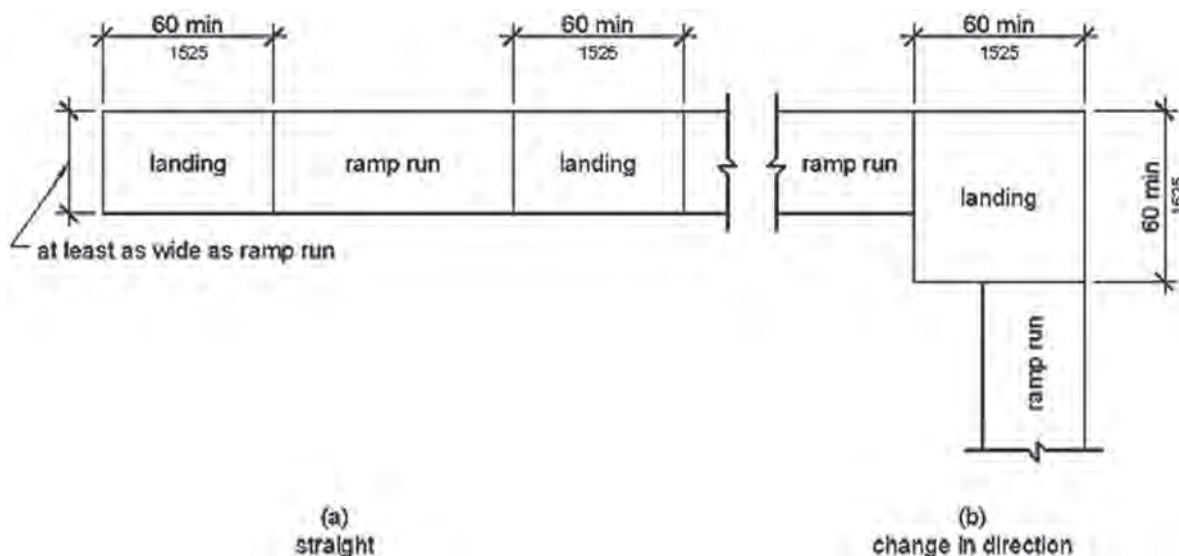

Ramp

Landings

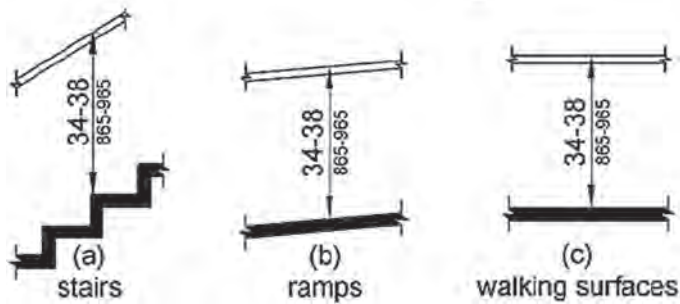

Handrail Heights

Stairs and ramps have some needs in common. *Both should have handrails on each side. These handrails should be one and one quarter inches in diameter. Non-slip surfaces are a must on both. Stairs and ramps should be well lit. If level changes are minimal, and there is space to provide one, ramps are preferred over stairs.*

*When ramps are utilized, they should be no steeper than a one-inch rise for each foot in length. The maximum rise for any single length of a ramp should be thirty inches. Five-foot-wide landings are needed at entries and exits to ramps. If in the open, raised curbs at least two inches high are needed on the sides of ramps to prevent wheels from slipping off. If inside, long hallways are excellent places in which ramps can be easily added to transition between levels. But entry doors alongside ramps will need to be relocated, so they are not in the middle of a ramped hallway.*

In many cases, due to space constraints, stairs will still be needed to accomplish changes in levels. This must be done, despite knowing stairs can be dangerous for people with deteriorating hips, knees, backs, vision, etc.

Measures can be taken to lessen potential harm. *Stair edges can be highlighted with contrasting colors or some other way to visually distinguish the edges of treads.* Stairs with shorter risers and fewer steps between landings are easier for the elderly to navigate. Interior stairs should have risers between four and seven inches tall and treads should be between eleven and fourteen inches deep. Stairs with intermediate landings that change direction can shorten the distance that will be fallen, should a slip occur. Provided landings should be the full width of a stair and at least five feet long.

Consider placing a call button near floor level at the bottom of stair runs, to call for aid in the event of an accident.

### Additional Vertical Transportation:

Vertical transportation is in no way considered a necessity. Other levels than the main floor of a home might simply become inaccessible, if stairs cannot be climbed and a lift cannot be installed. These can be closed off, used only as guest quarters and storage, or accessed from outside the

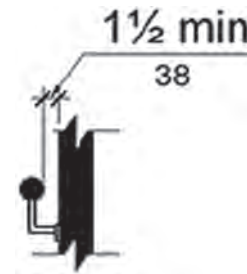

Handrail Clearance

home and used as rentals. Usually the only way to regain that space for a handicapped resident is to install a chair lift or some form of an elevator.

If one is provided, an elevator should be easy to locate and easy to use. In most homes, full size elevators are not options, but rather a Limited Use elevator is installed. *Platform lifts use the least amount of space where there is no space for ramps, limited use or full-size elevators.* Most elevators, if their controls are large enough to be easily seen and used, have already been designed for use by the physically impaired. *If building a new home, even if not needed now, plan a couple closets to be located directly above one another. These should incorporate removeable floor framing so a chase can be created later for a lift or elevator, should one be needed in the future. These should be the minimum dimensions of the intended elevator.*

Chair lift products that can propel a seated person up and down an existing flight of stairs are available and getting better with each passing year.

Illustrations below indicate dimensions of some Limited Use Elevators, to give some idea of space that might be required on each level to be accessed.

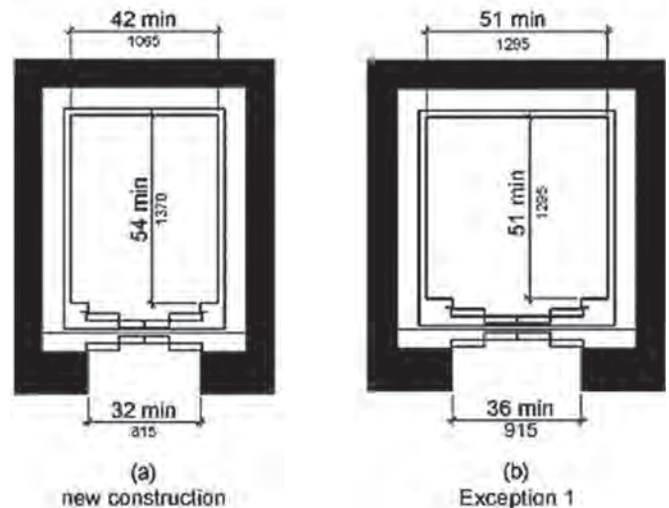

Space Requirements for Limited Use Elevators

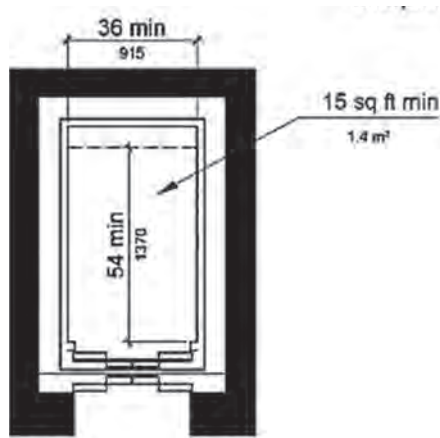

(c)  
Exception 2

### Space Requirements for Limited Use Elevators

Recessed areas in concrete floors can be provided in new construction, to set area carpets down into, but this is not likely to happen in renovations. The best option is to create recessed areas with other types of raised flooring materials around the carpet, that will result in any carpet being used, being flush with surrounding surfaces. *Transition strips between adjacent flooring types of different heights that do exist, will help prevent tripping. Difficulty in walking over such changes can also be overcome with the use of a cane.* Diagrams below indicate maximum suggested height changes for safety.

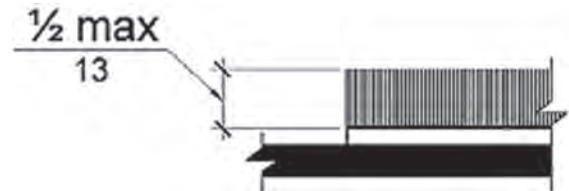

Suggested Carpet Height

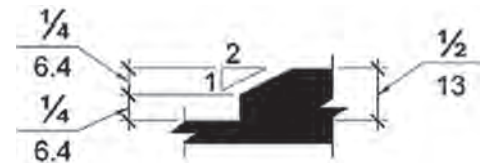

Beveled Level Change

### Finishes in General:

'Contrast' is one operative word when it comes to choosing finishes for aging-in-place. *Floors and walls should be of contrasting colors, so it is easy to distinguish the different planes.* Contrasting colors for countertops, cabinets and flooring can give visual cues to those with poor eyesight looking downward, as to which surfaces are which.

The second operative word is 'cleanability.' Choose durable surfaces for floors, walls and countertops to make them easier to clean. Hard surface paints like epoxy or enamel are easier to clean than other choices. Curved bases and rounded transition points, where base materials meet walls and floors, are easier to clean than ninety-degree corners.

### Flooring:

Choices made regarding flooring are of special concern to aging residents. This is simply because falls are so dangerous to their future.

*As is the case with bedrooms, durable, hard flooring materials like wood, vinyl and concrete are best used underfoot, where a tendency to shuffle can cause falls. The idea is to reduce situations where feet and heels can catch on a change in elevation of flooring like the piling of a carpet. Also like in bedrooms, carpet is sometimes desired for warmth. If used, limit carpet to small areas and use only carpet with tight, short piles that are easy to clean. Use a firm pad below such carpet. The firmer the carpet and backing, the easier it to roll over and less likely it is to trip over. Many options for this type of flooring are available in commercial grade carpets.* Area rugs with bound edges are sometimes considered, so they can be picked up and cleaned. But area rugs on hard surfaces can slip away and their edges, higher than surrounding flooring, still represent tripping hazards. If used, area rugs should have rubber backing and / or be secured down with double-sided tape.

Level changes present hazards as well, even level changes like transitions between hard floors and rugs or carpets.

Slipping on flooring presents as great a danger as tripping over it. *Get rid of any flooring that is slick, especially when wet. Use only non-skid flooring with a matte finish. If floors are to be polished, use a non-glare wax that is not slippery. Softer, more resilient flooring like cork, rubber or linoleum, is gentler on feet and can absorb some of the impact from falls. Using slippers with non-slip soles can create a measure of safety in the meantime.*

Understanding problems created by flooring colors and patterns will also help minimize problems. *The color of flooring should be changed at edges where a level change is about to occur.* Darker colors with subtle patterns will somewhat hide stains. Avoid using flooring that has dark patches in a lighter field or dark lines that can be mistaken for holes or even large cracks. These can be confusing for someone with diminished vision, crossing the area. Even flooring patterns containing recognizable objects like flowers should be avoided. Residents with dementia may be confused enough to bend to try pick them up, potentially falling in the process. Bright colors with high contrast patterns can be confusing. Stick with understated, uniform patterns.

As spills and incontinence are to be anticipated, hard surfaces and carpet that can easily be cleaned will be good choices. Keep in mind that unsealed concrete will absorb liquids of any type quite readily.

The matrix below compares interior flooring materials based on care, hazards in use, and ease of mobility.

Material	Cost	Location	Ease of Care	Hazards			Ease of Mobility		
				Least Glare	Slip Resist	Trip Resist	Feet	Walker	Wheel chair
Vinyl Comp Tile	Low	Back of Home	High Maint	Least Glare	Med Slip Resist	High Trip Resist	Easy	Easy	Easy
Luxury Vinyl Tile	Mid	Common Rooms	Low Maint	Med Glare	Med Slip Resist	High Trip Resist	Easy	Medium	Medium
Sheet Vinyl	Mid	Fitness / Bathrooms	Low Maint	Med Glare	Med Slip Resist	High Trip Resist	Easy	Easy	Easy
Rubber	High	Fitness	Med Maint	Least Glare	High Slip Resist	High Trip Resist	Medium	Medium	Medium
Porcelain Ceramic Tile	Mid	Lobby Reception Bathroom Corridor	Med Maint	Med Glare	Med Slip Resist	Med Trip Resist	Medium	Hard	Medium
Carpet	Mid	Office Quiet area Corridor Living	Med Maint	Least Glare	High Slip Resist	Med Trip Resist	Hard	Hard	Hard
Wood	Mid	Lobby Dining	High Maint	Most Glare	Poor Slip Resist	Med Trip Resist	Medium	Medium	Medium

## Windows:

In a startling late-night development, I once tried to break into a home where an aged member of our church had locked herself out. Imagine my sense of triumph when I managed to work a stiff paper clip through the joining sashes of a single hung window and pulled open the lock holding it shut. Imagine my surprise, when the window still could not be opened. It turned out my elderly friend had driven nails through each side of each sash of every one of her windows, into the window jambs. With that discovery, we called a locksmith.

For any who are wondering, nailing your windows shut is a good way to ensure that if rescuers do need to enter your home for any reason, and no time to await a locksmith, your glass is going to get broken.

Better options for window security, in homes owned by the elderly, do exist. Drop down or drop in bars to limit opening operations can be effective and easily utilized security measures. But they may also conflict with local fire regulations. It's a good idea to check first before installing them.

Besides security concerns, there are other factors making windows user friendly for aging-in-place. Keep in mind that different windows require different amounts of strength to operate. Sliders require less effort to open than single hung units. Crank out casements can be surprising difficult to operate, depending on the hardware used in their design. If windows close to the floor are also single-hung or double-hung windows, residents may find it difficult to stoop down and pull them up to allow in fresh air. While windows closer to the floor allow better unobstructed views, they also increase the potential for falling through glass. For this reason, glazing within eighteen inches of floor should be of tempered glass. *Large windows to admit daylight will improve moods and offset energy bills, by making the use of supplemental lighting unnecessary during daylight hours. Lower windows down to accomplish this or use taller windows with higher head heights.*

Ease of use will play a large part in how much windows are used to allow in fresh air and cross ventilation. *Window hardware needs to be easy to operate.* Window locks should be easily operated, requiring minimal gripping or pinching. *Select windows with maintenance free exterior and interior finishes.*

## Window Coverings:

Window coverings obviously allow incoming levels of natural light to be adjusted by a resident. Blinds reduce views, but can also block them out entirely, partially dampen sunlight or even redirect it up toward the ceiling to indirectly light a space. Shades, whether automatic or manual, can provide complete coverage from glare in various levels of opacity. Shades can be installed to pull from the bottom up or from the top down. Drapes are an older alternative to shades. They are also a bit more difficult to operate and bring cleanability issues with them. For any covering device, pull cords can be difficult for arthritic hands to operate. Circular chains are considerably easier to grip and manipulate.

## Doors:

Successful aging-in-place will always require access to any spaces needed to function independently. Very obviously, if an opening does not exist through which access can be accomplished, that space is no longer available for use to anyone using a wheelchair. For this reason, careful attention should be paid to needed access widths through openings and clearances around doorways.

### Needed Clearance Varies by Door Type:

There are certain minimum widths needed to permit passage of a wheelchair. This is generally thirty-two inches if the wheelchair is approaching the opening straight on. *Because door widths and hinge openings use up available width, if a swinging door is used, it needs to be a minimum of thirty-*

*six inches wide. It should also use offset door hinges. If that is not available in any opening, it will be necessary to eliminate the door, change the door type or install a new and wider door.*

All doors, regardless of type or location, occupy space when they are open. Open doors should not block further access down a hallway. Bi-fold doors opening into hallways take only half the width of a hallway than do regular swinging doors. Other door types provide more clearance through openings, when the door is open. Given the absence of a door swing to maneuver around, sliding doors provide more clearance than swinging doors. Barn doors and pocket doors allow for full use of the entire doorway width. Just as a side note, most barn doors don't completely seal an opening for purposes of sight, sound or smell. But if wall space exists for the track, they are easy to retrofit in existing homes.

Regardless of type, doors must remain easy to operate for aged hands. Unless properly maintained, most pocket doors can develop problems sliding in their tracks and in locking when closed. Pocket doors needing to be grasped while in the pocket and pulled back out, are difficult for aging residents to use. *Patio doors and screens should be easy to lock. No door should require no more than five pounds of force to open.*

The illustrations below denote clear widths required at different types of doors, when approached from different directions. Almost no existing home can provide all these clearances, but they are worth trying to obtain.

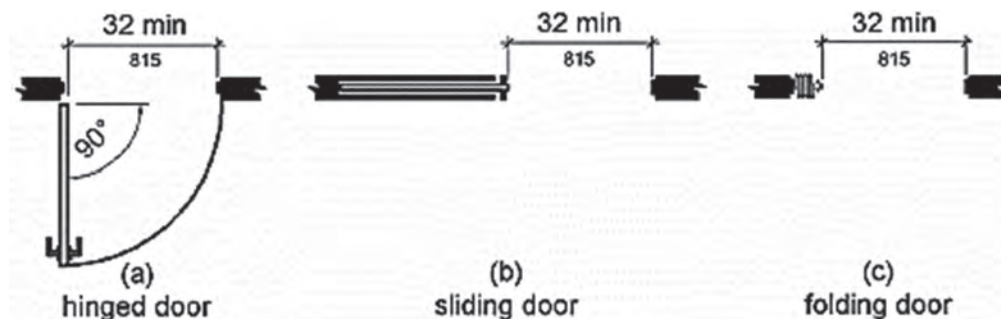

Clear Width Required at Doorways

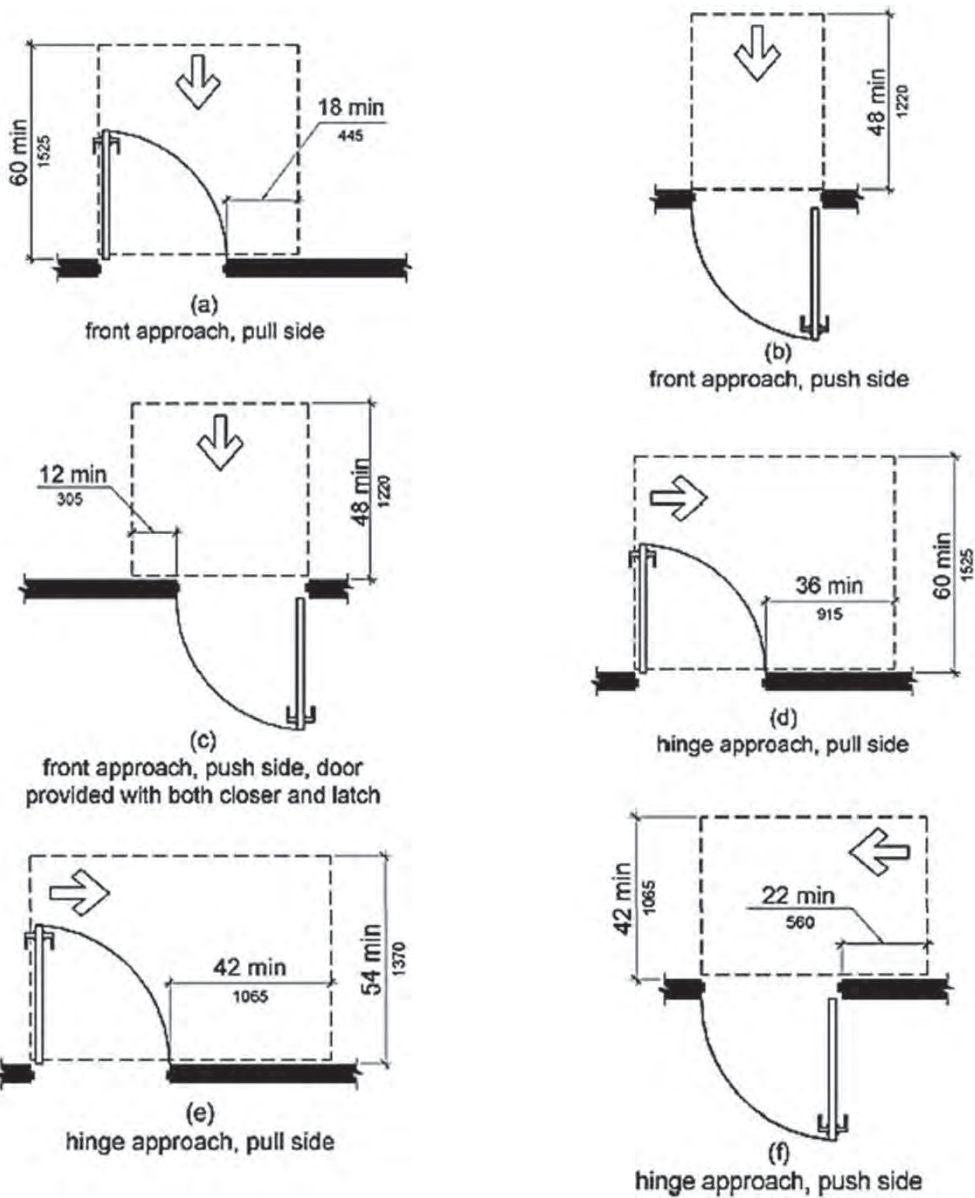

Maneuvering Clearances at Swinging Doors

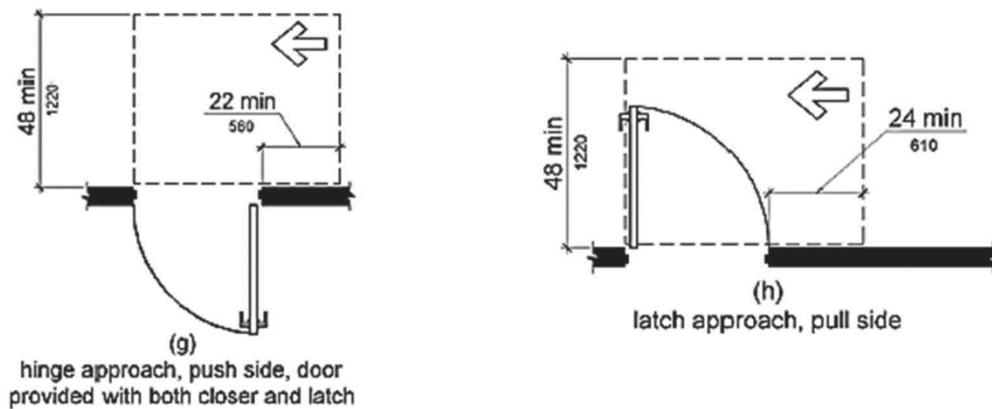

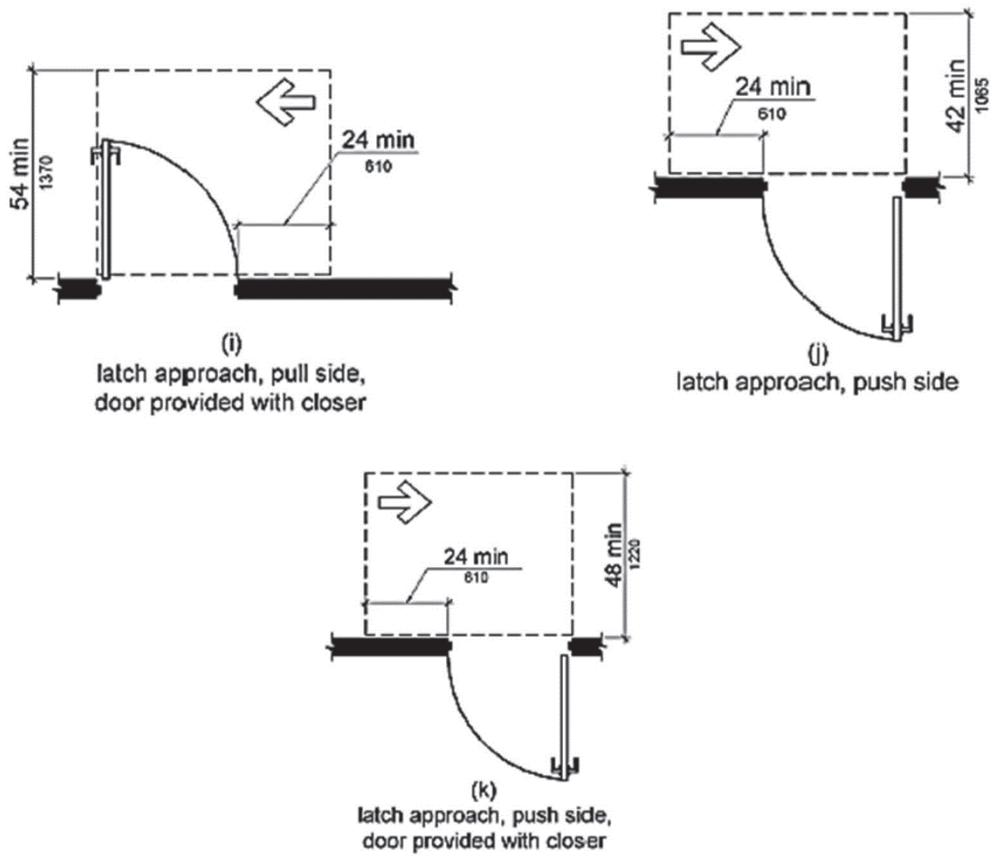

Additional Maneuvering Clearances at Swinging Doors

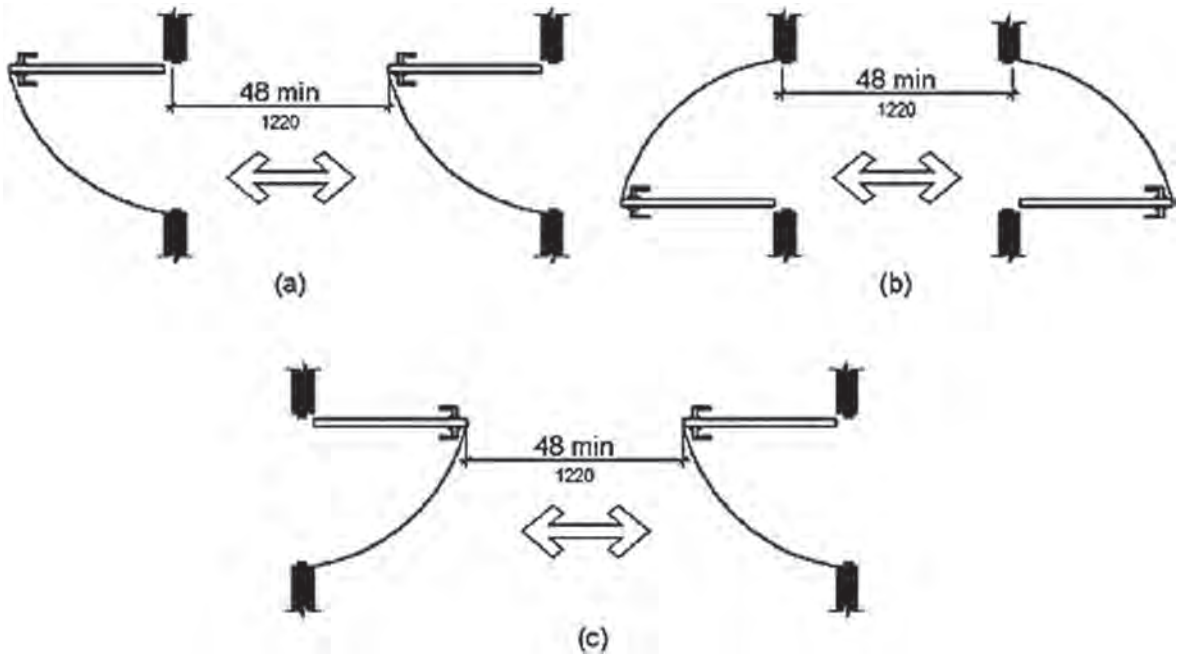

Maneuvering Clearances at Doors in Series

### Hands-Free Entry:

Doors that are easy to operate will be used, while those which are not are better called 'barriers.' Doors that are automatically activated from a pressure pad or motion sensor, or that operate from a push plate, make entry while carrying packages much easier. They are also a lot more expensive than standard entry doors and seem less secure. But in buildings with multiple tenants, they are an asset. Easily operated double swinging doors, entering areas like laundry rooms, are useful when carrying baskets or using mobility assist devices.

### Door Hardware:

While I have other issues creeping in with age, arthritis has thankfully not yet been an issue. But for a large part of the population, this is not true. This crippling condition makes the use of some door hardware difficult. *For this reason, and to compensate for loss of strength, door knobs should be changed out to handles. Lever handles are the easiest hardware to grip and turn.* Use of door hardware should not require pinching, a tight grip or unusual strength to turn. Doors that can be pushed open work well. Large loop pulls are good for barn doors.

Level changes from one side of a doorway to the other should be minimized or non-existent. Make sure all flooring transitions between rooms defined by doorways, have transition strips in place to help prevent tripping. *Thresholds that represent tripping hazards can be replaced with no-step or compressible rubber thresholds for safety and easier access for wheelchairs.*

The swing of a door will also need consideration when planning to age in place. Arrange doors to swing into rooms so access space leading to them is not compromised by the opening of the door. The exception to this is bathrooms. Bathroom doors should always be mounted to swing outward, since someone fallen inside will prevent an in-swinging door from being opened to help them. If a door will have a lock, it is best to have that door swing outward so hinges can be accessed and dismantled, in the event of an emergency and a non-responsive resident inside the room.

If able to be installed without compromising safety, glazing inserted in doors can help residents with wayfinding issues determine the use of a room before entering, as well as giving caregivers an unobtrusive glimpse inside.

### Furnishings:

Continuing to use a home may require some changes in furnishings. Usually this will involve finding replacements which are smaller. Clearance must be first obtained and then maintained around furniture, so mobility assist devices can be used.

Some furniture is simply no longer usable as aging occurs and should be replaced for no other reason than that. Chairs and other seating lower than eighteen inches from

the floor will be difficult to rise from. Bar stools are not very useful to the elderly either. If a seat goes back too far, the surface is too low to the ground to rise from easily or so soft the user sinks down in it, that couch or chair won't work well for anyone with back, knee, hip or arm strength issues. *Provide sturdy chairs with armrests so users can depend on them for support while rising.*

The ongoing human desire to change our environment by rearranging furniture can still be somewhat accommodated. Lightweight furniture, so long as it is still sturdy, is easier to rearrange if a change is desired. If furniture has wheels under it to assist in movement, they should only be on the front corners and not the back. Otherwise, furniture can roll backwards when users sit down, leading to bad falls. If furnishings will be moved often, select flooring that won't be scratched while doing so.

Furniture should also be selected to be physically friendly to users. Padded arms are a good idea for those who bruise easily. They should extend all the way to the front of the seating. If existing furniture to be retained doesn't have them, add firm foam pads to chair and sofa seats. If there are issues of incontinence, hard surfaces or waterproofed surfaces are easier to clean than those which are absorbent. Fabric should be easy to clean. Furniture designed with openings where seats meet backs is also easier to clean when liquid gets spilled on it. Liquid won't collect in crevices that do not exist.

### Acoustics:

Hearing diminishes as aging occurs, especially in the high and low ends of the frequency spectrum. Some sounds can even become painful to eardrums less elastic than before. Unwanted noise will tend muddy the sounds residents are seeking to comprehend. Such hearing issues are very frustrating and those suffering from them, tend to isolate themselves.

Devices to assist in hearing are the best solution to this, but design choices in the home can also help somewhat. Since sound travels in a straight line, partitions can be used to block unwanted noise. Sound absorbent furniture, drapes and finishes can be used to absorb noise, reduce muddying echoes and increase clarity. Small seating areas encourage people into proximity, so conversation becomes easier.

## review questions...

16. \_\_\_\_\_ will be one of the most difficult tasks faced in preparing a home for aging-in-place.
- Accumulating cash reserves
  - Decluttering
  - Preparing logical arguments
  - Deep cleaning
17. When planning maneuvering, the amount of floor space occupied by a wheelchair is considered to be a minimum of \_\_\_\_\_.
- 48" x 30 "
  - 60" diameter
  - 48" x 60"
  - 32" wide
18. If possible, all necessary spaces in a home where aging-in-place can occur should \_\_\_\_\_.
- Be in clear line of sight
  - Contain space for a hospital bed
  - Be available on one single level
  - Contain at least one phone jack
19. Unless they are taped down or have proper backing, \_\_\_\_\_ may become tripping hazards.
- Wipe-off mats
  - Area rugs
  - Office chair mats
  - Chairs on castors
20. \_\_\_\_\_ are a great invention keeping kitchens safe to use.
- Induction cooktops
  - Wall mounted pot sprayers
  - Drop-in sinks with knee space
  - Shorter bar stools
21. There should always be \_\_\_\_\_ on counters next to appliances.
- Open work space
  - Racks for commonly used dishes
  - Backdraft exhaust hoods
  - Medication dispensers
22. \_\_\_\_\_ is the item in kitchens most often needing to be replaced for reasons of safety.
- The flooring
  - The stove
  - The water mixing valve
  - The gas shut-off valve
23. The top of an accessible toilet should be between \_\_\_\_\_ and \_\_\_\_\_ inches.
- 14, 16
  - 15, 17
  - 16, 18
  - 17, 19
24. \_\_\_\_\_ should be provided in any space where standing water can occur.
- Water absorptive flooring
  - A floor drain
  - Epoxy grout in joints
  - Slip resistant flooring
25. There should be \_\_\_\_\_ between a bedroom and a bathroom to be used.
- A clear line of sight
  - Hard surfaced flooring
  - No place for a pet to lie
  - Less than four steps
26. If front loading laundry appliances are used, they should be raised off the floor \_\_\_\_\_.
- On recessed pedestals
  - Between 12-15 inches
  - No more than 24 inches
  - High enough to create knee space below
27. Which of the following is not needed on stairs and ramps?
- Runs in one direction only
  - Handrails on both sides
  - Adequate lighting
  - Non-slip surface
28. \_\_\_\_\_ tend to be used in residences, rather than full size elevators.
- Escalators
  - Open lifts
  - Limited use elevators
  - Dumbwaiters
29. \_\_\_\_\_ should be used at edges where a level change is occurring.
- Audible alarms
  - A change in flooring color
  - Two handrails with space to walk between
  - Strips of reflective tape
30. When carrying baskets, a door type permitting hands-free entry is a \_\_\_\_\_.
- Double swinging door
  - Pocket door
  - Barn door
  - Bi-pass door

## ALARMS AND ALERTS

Everyone needs a helping hand from time to time. The trick is to be able and willing to let others know we need help.

Electronic devices can help notify others. *It's a good idea to obtain and have at hand for our elders, a personal emergency alert system. A flashing porch light or 911 switch is another option that can be made available. Direct wired alert systems are available that can be used to call for help from relatives, and / or police, fire and EMS services, at the touch of a button. Hopefully, this button will also be out of the reach of small children. Intercoms should be installed so residents can communicate with outside visitors from the bedroom, kitchen or living areas.*

Some emergencies are bigger than those coming from inside the home and the aged need to be prepared for those as well. Limited mobility might make it hard for some residents to get out of a building quickly. Use alarm devices with both visual and audible cues that are sensitive enough to heat, smoke and CO2 to give users plenty of time to respond. Potable water and medicines needing refrigeration should be stored in a small refrigerator connected to a small emergency generator. Such an emergency generator need only be sized large enough to power a refrigerator, alarm systems, the HVAC system and a few emergency lights and outlets. Enough non-perishable food should be on hand to last a few days as well.

## Emerging Technologies:

New technologies are being developed that can be incorporated into home care to advance safety and create a better environment for aging-in-place.

Some gadgets are designed to minimize the need for personal daily verification of the safety of aged residents who live alone. Remote caregivers can monitor and engage with residents via tablets and avatars. Artificially intelligent 'pets' have been created to look just about like real ones, but need no grooming, food or waste disposal and suffer nothing when neglected. They provide needed company to minimize feelings of isolation and just need a power port. Humanoid robots are being developed to assist with household chores, while even providing a certain level of socialization.

Other automated devices serve to protect those aging-in-place. Automatic medication dispensers can help prevent accidental overdoses or omissions in taking medicine by confused patients. They can become large when they contain enough medications for a week or more, so setting dispensers on countertops can use up a lot of room. They can alternately be mounted on wall shelves, on walls or in niches. GPS based systems track dementia patients wearing a bracelet or key chain tag, without restricting their movement. The system monitors them as soon as they leave their home. It also alerts caregivers when the exit is made, so caregivers can also begin monitoring

the wanderer. Video cameras, sending live streaming to monitors, help loved ones remotely monitor the wellbeing of residents from a distance.

## Other Sensor Based Technologies:

A myriad of other sensors can protect the health and safety of the aged.

Many such devices track movement. Motions sensors throughout a living unit can detect movement so caregivers know when a patient is up and moving. Door monitors track and record every entry and exit. If motion stops, they can signal a fall and call for help. Wrist trackers can monitor steps and how many are taken, to ascertain levels of exercise. A voice activated wrist band can be used to give a wandering patient direction on how to return home. *Any alert devices that signal for help should include GPS positioning, otherwise help may arrive at a residence while the wearer of the device is elsewhere.*

Sensors can track daily activity inside a residence. Wireless, wearable sensors allow family members to connect from a distance without interfering in routines. Information is constantly being sent to a dashboard to pick up on early signs of trouble, like number of trips to a bathroom. Notification of changes in patterns give caregivers an option to personally check-in to verify all is well. Sensors can be placed to track eating habits by registering openings of a pantry or refrigerator door. Their lack of use might indicate a loss of interest in eating. Smart home technology can allow remote caregivers to verify that doors are locked at night, windows are secured, appliances that need to be, are turned off and so forth. Home safety sensors can be deployed to monitor unattended stoves and shut them off if the temperature gets too hot or they are left on too long. Water sensors can detect flooding in sensitive areas. Temperature sensors can monitor and regulate water temperatures to prevent scalding and even air temperature in the house to adjust HVAC unit thermostats.

Other sensors relay health information. Door sensors can be used to track how often a resident opens a medicine cabinet door or if they fail to do so at a predetermined time. Some sensors sync with automatic pill dispensers. Voice activation wristbands can be used to remind residents it is time to take medications, if sensors detect they have failed to do so. Some monitor and record vital statistics. Bathroom sensors can record the number of times a toilet is flushed and how long a resident is in a bathroom. There are even sensors that can detect a fall that is happening and deploy wearable air bags to minimize injuries. Sensors under pillows can detect and record sleep patterns, including when a user rises and lies back down. Some bracelet sensors can even detect REM patterns. Robotic devices monitor health and allow doctors to remotely complete medical examinations with aging residents in their homes.

## HVAC SYSTEM CONCERNS

Decreased circulation occurring with aging makes us more sensitive to changes in temperature and air movement.

HVAC systems should be designed or modified with additional needs of the users in mind and they should allow individual control by users. *Make sure all bedrooms have an air return, introduce fresh air into the home mechanically with an intake on the system and use CO2 detectors to maintain a safe air quality.* Place supply and return vents in perimeter walls where they can be more easily adjusted, than when they are at floor level or even worse, at ceiling level. Avoid installing systems that distribute treated air with air movement strong enough to create drafts. If possible, locate possibly noisy air handlers by or over bathrooms or closets, not near sleeping or living areas. Likewise, locate outside condensing units away from windows that will be left open and away from outside gathering spaces. *HVAC systems should be designed so it is very easy to change filters, even from a seated position.*

Control of systems should be easily understood by aging users who do not care for new technology. *Large and easy to read and operate thermostats should be in a well-lit area at a comfortable height. Thermostats are available that accept wireless commands, voice activation or even pre-programming so residents won't need to be making constant changes.* Home automation systems can combine HVAC controls, lighting and security into one system, but may be beyond the capacity of some to properly operate.

Residents on limited incomes will appreciate any modifications that will lower ongoing utility bills. *Energy efficient units will be welcomed. Often these will be gas-fired furnaces with air-conditioning units joined to them. Seal ductwork with mastic. Seal the house with barriers to unwanted air infiltration. Verify that exterior walls are properly insulated and takes steps to remedy any which are not. If windows are being replaced, install energy efficient models with Low-E glass.* Protect ductwork from debris when renovations are in process, so dust does not accumulate in ducts to be blown back out later.

Climate control in individual spaces can be realized without necessarily changing a thermostat and altering the climate for the entire residence. Variable speed ceiling fans can increase comfort and mix air that has stratified into thermal layers. Make sure exhaust fans in bathrooms can quickly exhaust humid air and steam. Make sure they are not so noisy that they will just be left off. Exhaust fans can be switched to operate with the lights or even with an occupancy sensor. Radiant ceiling panels in bathing and dressing areas can be installed to be controlled by switches and will provide immediate warmth when needed and activated. Timers can be installed to turn them back off.

## ELECTRICAL CONCERNS

### General Lighting Concerns:

Electrical issues involved with aging-in-place primarily involve ensuring adequate lighting and a safe placement of enough outlets to minimize undue effort to plug in appliances. *Simple steps to be taken include raising electrical outlets and lowering switches as needed to increase usability. Another simple precaution is to place and somewhat secure, electrical cords and phone cords along the base of walls and out of the way of foot traffic.*

*In the area of illumination, fading acuity of eyesight may require adding lighting to raise overall levels.* Inadequate lighting can make navigation dangerous and make household tasks difficult to complete. One way to combat this is the use of general lighting at one level to keep down overall glare, while having other fixtures generate higher light levels at task locations. Having extra outlets available for portable lamps helps get light into needed locations. Touch control lamps can be purchased and are easy to control without fine motor skills. Illuminate steps, ramps and flooring level changes to help eliminate falls.

Added lighting can be controlled in intensity, glare and color. *LED lights can be used in existing lights to free up capacity on existing circuits needed to power additional fixtures. LED bulbs can be purchased in a warm color range, between 2,700 and 3000 Kelvin. Look for a color rendering index close to 100.* Full spectrum bulbs can be purchased to simulate the appearance of daylight. *To avoid glare, some lights can be aimed at and bounced off ceilings and walls, to provide indirect lighting while avoiding glare from visible bulbs. Use automatic motion sensing lights in areas like hallways, kitchens and bathrooms to ensure they are lit when in use.*

A few other concepts concerning lighting are worth mentioning. Large windows can create a lot of contrast between themselves, the areas they illuminate and nearby non-daylit areas. Though their perceived darkness is somewhat of an illusion, those contrasting areas should contain additional light sources. Added light fixtures should also not be hung so low that residents must duck to avoid them.

### Lighting Control Types:

Besides the addition of the lights themselves, some attention should be paid to how they are turned on and off. *This may sound simple, but light switches should be next to the entrance of each space they serve. It should not be necessary to cross a dark space to turn on lights. Switches and environmental controls should be between thirty-six and forty-eight inches above the floor. There should be a clear space of thirty inches by forty-eight inches in front of switches and controls.*

*The type of switch installed will also determine how and even if provided illumination is used. Light switches should not require fine motor skills to operate. Small push buttons and*

*slides are more difficult than simple toggle switches, large buttons and rocker switches. Light switches that are illuminated will prevent a search in the dark for the controls.* Dimming switches can allow users to easily change lighting levels in a space. Occupancy sensors to turn on lights upon entry, eliminate the need to free up a hand for use. Programmable illumination that changes lighting scenarios at the touch of one button is ideal, but expensive.

A few additional changes involving lighting may also prove beneficial. *Lighting fixtures in crucial spots, like near entry points or in bathrooms, should contain at least two bulbs. That way, bulbs need not be immediately changed if one fails. Audible and visual light systems should be triggered by doorbells, smoke, fire or CO2 detectors.*

In a bit of reverse reasoning, a lack of light can also help deter residents with early dementia from wandering out through entryways. Darkened doorways are less inviting. This seems counterintuitive to the need for adequate light when entering the home, but levels can be controlled by having brighter entryway and foyer lights turned on by motion sensors.

## Outlets:

Outlets should be plentiful and may need to be closer than the code mandated spacing of twelve feet. *Cords should not need to be stretched across open areas and become tripping hazards.* Place outlets and phone jacks where they will be convenient and easy to access, even from wheelchairs. These can be on the front of cabinets, islands or side walls. Higher outlets are easier to access than those near the floor. Do not locate outlets next to areas where they may get wet, unless they are on GFI circuits.

*Homes should be also wired for security and for computers.*

## ADDITIONAL THOUGHTS

### Cost:

Some of the upgrades recommended in the body of this text cost little or nothing. Some, such as upgrading to LED fixtures and bulbs, will pay back more over a few years than they initially cost. For information on what many of the recommended upgrades cost, the AARP has published a guide entitled 'HomeFit Guide.'

There are numerous agencies in the U.S. that offer assistance in making dwellings accessible for low-to-moderate income residents. In many cases, qualifications for these programs include:

- The occupant is physically disabled or has difficulty leading a normal life because of aging
- The unit under consideration is a permanent dwelling unit
- The total household income is below a stated threshold.

Weatherization Assistance programs are also available to provide energy-related upgrades. Priority is usually given to the aged and disabled. Utility companies are a good source of information for these.

Upgrading an existing home can be financially daunting. That is when prioritizing needed changes becomes critical. Renovations must be ranked in priority by cost, impact on the user and which changes are the next most critical to the well-being of the user. Renovations to kitchens and bathrooms seem to find their way to the top of such lists. Aging-in-place costs are best considered when spread out over time. Renovations may also need to be done in stages, if the home must remain occupied during renovations.

### Additional Obstacles:

Besides opposition from the aging resident, and difficulties in funding needed improvements, there are at least three other parameters affecting an ability to make needed changes.

### What's Behind This Wall:

The answer to this question is that in most buildings, we won't know what we are dealing with until we remove the finishes on the face of walls. Therefore, costs tend to creep up in renovation projects. Doing what we intend may involve relocating plumbing or wiring, adding needed blocking or performing unforeseen alterations needed to meet current building codes. If lead paint, lead piping or asbestos is encountered, it will need to be removed.

### Cabinetry:

It is very unusual that existing cabinetry can be adapted to meet ADA recommendations for access, knee space, etc. While it is inexpensive to replace cabinet hardware for ease of use, removing the old and installing new cabinets will become costly.

### Footprint:

Working inside the footprint of existing buildings can be frustrating. As stated before, it will likely be necessary to take space from one room to add it to another. In multi-tenant buildings, a unit can be sacrificed to create needed common areas, but that option doesn't exist in single-family homes. In the best cases, a bedroom will be available that can be sacrificed to make more room elsewhere. Unused dining rooms are often cannibalized to obtain additional needed space.

Walls can sometimes be eliminated to create more usable open spaces. When moving or removing walls, it will be very important to consider the electrical wiring and plumbing inside them, as well as whether the wall is a primary structural component providing bearing. While it is possible to remove portions of bearing walls, it is neither easy nor inexpensive.

## CONCLUSION

It is rare to find anyone desiring to move from their home into a congregate care facility, due to aging. If they can at all manage to do so, those with homes and family they raised in those houses, will inevitably want to stay in their own house for as long as humanly possible.

Since inevitable consequences of aging will otherwise force them out, it will be up to us to determine the level of effort we are willing to exert to honor their wish to remain in place. Make no mistake about it. If not originally designed to be user friendly to the elderly, it will take ongoing time and expense to make the changes to a residence needed to accommodate them till their inevitable departure. Perhaps as much effort as it took them to adapt their homes for our arrival.

My hope is that this writing will help clarify, when and where our assistance can do the most good.

## OTHER AVAILABLE RESOURCES

### General Aging-in-Place:

Enterprise Aging-in-Place Toolkit & Charrette Toolkit with added language for communities pursuing aging in place strategies - <http://www.enterprisecommunity.com/solutions-and-innovation/enterprise-green-communities/re-sources/charrette-toolkit>

Enterprise Aging-in-Place Existing Building and Site Evaluation Checklist - <http://www.enterprisecommunity.com/resources/ResourceDetails?ID=0101080>

Aging in Place – A Toolkit for Local Governments by AARP - <http://www.aarp.org/content/dam/aarp/livable-communities/plan/planning/aging-in-place-a-toolkit-for-local-governments-aarp.pdf>

National Aging-in-Place Council - <http://www.ageinplace.org>

National Institute on Aging - <https://www.nia.nih.gov/>

Design for Aging & Aging-in-Place Toolkit by American Society of Interior Designers (ASID) - <https://www.asid.org/content/design-aging#.Vsetd00m6Uk>

Design for Aging Knowledge Community – American Institute of Architects (AIA) - <http://network.aia.org/designforaging/home>

National Association of Home Builders Aging In Place Remodeling Information Site - <https://www.nahb.org/en/consumers/homeownership/aging-in-place-vs-universal-design/aging-in-place-remodeling.aspx>

APA: Planning Aging-Supportive Communities - <https://www.planning.org/publications/book/9026902/>

Finding a Certified Aging-In-Place Specialist from the National Association of Home Builders -

[https://www.nahb.org/en/find/directory-designee.aspx#sort=%40lastname44362%20ascending&f:@fdesignationsheldabbreviation44362subl\\_c\\_oveofacets\\_0=\[CAPS\]](https://www.nahb.org/en/find/directory-designee.aspx#sort=%40lastname44362%20ascending&f:@fdesignationsheldabbreviation44362subl_c_oveofacets_0=[CAPS])

### Specific Topics:

Handbook for Designing Roadways for the Aging Population by the Federal Highway Administration - [http://safety.fhwa.dot.gov/older\\_users/handbook/](http://safety.fhwa.dot.gov/older_users/handbook/)

Flooring Slip Resistance: Products that meet ANSI/NFSI B101.1-2009 - <https://nfsi.org/certifications/certified-products/>

### General Building Resources:

International Code Council - <http://www.iccsafe.org/>

National Fire Protection Agency - <http://www.nfpa.org/>

### Accessibility / Universal Design:

2012 Enterprise Green Communities Single & Multifamily Universal Design Specifications - <http://www.enterprisecommunity.com/resources/ResourceDetails?ID=0084050>

Americans with Disabilities Act - <https://www.ada.gov/>

Fair Housing Authority - [http://portal.hud.gov/hudportal/HUD?src=/program\\_offices/fair\\_housing\\_equal\\_opp](http://portal.hud.gov/hudportal/HUD?src=/program_offices/fair_housing_equal_opp)

Universal Design - <http://www.universaldesign.com/>

### Health During Aging:

Alzheimer's Association - <http://www.alz.org/>

Alzheimer's Foundation of America - <http://www.alzfdn.org/>

Arthritis Foundation - [www.arthritis.org](http://www.arthritis.org)

Silver Sneakers - <https://www.silversneakers.com/>

## REVIEW QUESTION ANSWERS

1. **Illustrated guidelines for handicapped access to public facilities were published by the \_\_\_\_\_.**
  - a) National Handicapped Institute – incorrect, this is a nonprofit corporation for the purpose of improving the independent lifestyles of persons with physical disabilities, specifically mobility impairments
  - b) Center for Disease Control – incorrect, the CDC facilitates more for the health security of the nation and not handicapped access.
  - c) National Council for Aging-in-Place, incorrect, this council is a support network that connects service providers with elderly homeowners.
  - d) **United States Access Board, correct. This board is a federal agency that promotes equality for people with disabilities through leadership in accessible design and the development of accessibility guidelines and standards for the built environment, transportation, communication, medical diagnostic equipment, and information technology.**
2. \_\_\_\_\_ **is not one of the tests used to identify issues with balance.**
  - a) Easily carry items like grocery bags and laundry baskets - incorrect, this is an action that you should use to determine if you or a loved one can easily and safely perform to check yours/their balance and physical strength.
  - b) **Successfully walk along the edge of a curb - correct, this is not something one should try to do to test their balance or strength as it is not safe to do.**
  - c) Properly use all appliances - incorrect, this is an action that you should use to determine if you or a loved one can easily and safely perform to check yours/their balance and physical strength.
  - d) Climb up and down stairs with confidence - incorrect, this is an action that you should use to determine if you or a loved one can easily and safely perform to check yours/their balance and physical strength.
3. **When suggesting changes be made for aged loved ones, don't expect to encounter \_\_\_\_\_.**
  - a) **Gratitude – correct, no one likes change and many aging loved ones will resist suggestions on what is needed to keep them safe.**
  - b) An offer to pay for them - incorrect this is not a true option
  - c) Regulatory resistance - incorrect most time regulatory mandates are required
  - d) Schedules with room in them - incorrect most elderly people have room in their schedules
4. \_\_\_\_\_ **are used to eliminate a need for possibly painful step downs and step ups.**
  - a) **Curb cuts - correct curb cuts eliminate the need to step up and down.**
  - b) Mobility-assist devices like Segways - incorrect, segways don't take steps up and down
  - c) Paving materials graded absolutely flat - incorrect, paving materials have nothing to do with step ups and downs.
  - d) Small, lightweight personal ramps - incorrect, people will not carry personal ramps with them everywhere they go, its not reasonable.
5. **Exterior obstacles that can prove to be hazardous to canes, walkers and mobility-assist devices are \_\_\_\_\_.**
  - a) Thorn bushes - incorrect, while thorn bushes are not fun and can be hazardous they are not hazardous to canes, walkers and mobility-assist devices
  - b) Curb cuts - incorrect, generally curb cuts are best for people with canes, walkers, and mobility-assist devices
  - c) **Grates with openings - correct, these are hazardous to canes, walkers, and mobility devices**
  - d) Sloped pavement - incorrect, slopes are usually helpful if not too steep
6. **The flared sides of a curb cut should have a maximum \_\_\_\_\_ slope.**
  - a) **1:10 - correct this is the max slope**
  - b) 1:12 - incorrect, the maximum is 1:10
  - c) 1:4 - incorrect, the maximum is 1:10
  - d) 1:8 - incorrect, the maximum is 1:10
7. \_\_\_\_\_ **is an exterior surface considered to be the worst for mobility.**
  - a) **Pea gravel - correct pea gravel is the worst followed by grass**
  - b) Concrete with a stiff broom finish - incorrect, this is better than pea gravel
  - c) Cinder block with minor gaps between - incorrect, this is better than pea gravel
  - d) Permeable paving - incorrect, this is better than pea gravel

8. **To permit wheelchair access, a drop from the top of a threshold to an outside surface is best kept to a maximum of \_\_\_\_\_.**
- 1 / 4" - incorrect, this is great but 1/2 inch is the maximum
  - 7 / 8" - incorrect, this is more than the 1/2 inch maximum
  - 3 / 4" - incorrect, this is more than the 1/2 inch maximum
  - 1 / 2" - correct, the threshold is best kept to a maximum of 1/2 inch**
9. **As a flooring surface, pavers are considered to have \_\_\_\_\_ and \_\_\_\_\_.**
- High maintenance, high glare - incorrect according to the matrix on surface materials this is not true of pavers.
  - Medium glare, high trip resistance - incorrect according to the matrix on surface materials, this is true of traffic coating
  - Low maintenance, low trip resistance - correct pavers are low in cost, low maintenance, low glare, medium slip resistance, and low trip resistance.**
  - Medium maintenance, medium glare - incorrect, incorrect according to the matrix on surface materials, this is true of traffic coating.
10. \_\_\_\_\_ is an important criterion for choosing exterior building materials as aging occurs.
- Low levels of reflectivity - incorrect, this generally is not an issue with exterior building materials
  - Low maintenance - correct, Exterior materials are best if they are low maintenance, requiring little ongoing effort to keep looking good. Examples include brick and vinyl siding.**
  - Resistance to insect infestation - incorrect, something to consider but not a super important criterion
  - Colors complimentary to the neighborhood – incorrect, not that important as far as building materials are concerned for the elderly.
11. \_\_\_\_\_ and \_\_\_\_\_ both act as streets through multi-family communities.
- Laundries, ATM machines – incorrect, these do not act as streets in multi-family communities
  - Corridors, elevators – correct, these are important travel spaces within a multi-family community that act as streets**
  - Concrete pavers, gravel paths – incorrect, these do not act as streets in a multi-family community
  - Lobbies, dining areas – incorrect, while generally busy areas in multi-family communities, lobbies and dining areas do not act as streets.
12. **Which of the following is not true of a lobby?**
- It's a good place to post transportation schedules – incorrect, this is very true of a lobby
  - They should utilize non-slip flooring – incorrect, this is very true of a lobby
  - Plants used in them should require minimal watering – correct, this really has no effect on a lobby.**
  - They should permit small group gatherings – incorrect, this is very true of a lobby
13. **Which of the following is not true of common restrooms?**
- A lack of them discourages the incontinent from attending public gatherings – incorrect, this is true of having restrooms available in common areas.
  - Several unisex bathrooms are preferred over those with multiple stalls – incorrect, this is true of common restrooms as most people prefer privacy
  - They should be in full compliance with ADA guidelines – incorrect, this is true as these bathrooms need to comply with ADA guidelines
  - They should contain long term storage for supplies like toilet paper – correct, this is not true as there is no need for a long term storage for toilet paper.**
14. **Items like mobility assist devices, power cords, evacuation chairs, phone chargers, etc. should be available for use in a closet near the \_\_\_\_\_.**
- Lobby – correct, this eliminates the need for residents to make multiple trips back and forth to their private spaces.**
  - Common dining areas – incorrect, a closet in the lobby is the best storage area
  - Waiting area off a laundry – incorrect, a closet in the lobby is the best storage area
  - Staff offices – incorrect, a closet in the lobby is the best storage area
15. **One common space used to slow down bone deterioration is \_\_\_\_\_.**
- A common dining area with available meals – incorrect, generally the dining room does not slow down bone deterioration in the elderly
  - A covered front entry open to breezes – incorrect, this will not have an impact on bone deterioration
  - A fitness center for moderate exercise – correct, exercise helps with bone deterioration**
  - A home theater with well-padded seating – incorrect, this will not have an impact on bone deterioration

16. \_\_\_\_\_ will be one of the most difficult tasks faced in preparing a home for aging-in-place.
- Accumulating cash reserves – incorrect decluttering is the most difficult task in preparing a home
  - Decluttering – correct, this creates space and is a necessary first step**
  - Preparing logical arguments – incorrect, not the most difficult task in preparing a home
  - Deep cleaning – incorrect, not the most difficult task in preparing a home for aging in place
17. When planning maneuvering, the amount of floor space occupied by a wheelchair is considered to be a minimum of \_\_\_\_\_.
- 48" x 30 " – correct this is the clear floor space needed for maneuvering a wheelchair**
  - 60" diameter – incorrect, 48 inches by 30 inches is the minimum floor space
  - 48" x 60" – incorrect, 48 inches by 30 inches is the minimum floor space
  - 32" wide – incorrect, 48 inches by 30 inches is the minimum floor space
18. If possible, all necessary spaces in a home where aging-in-place can occur should \_\_\_\_\_.
- Be in clear line of sight – incorrect, not necessary for aging in place spaces
  - Contain space for a hospital bed – incorrect, not necessary for aging in place spaces
  - Be available on one single level, - correct all necessary spaces in a home should be made available on one single level, with no steps between them.**
  - Contain at least one phone jack – incorrect, not necessary
19. Unless they are taped down or have proper backing, \_\_\_\_\_ may become tripping hazards.
- Wipe-off mats – incorrect, not generally a tripping hazard
  - Area rugs; correct, these can be tripping hazards**
  - Office chair mats – incorrect, not generally a tripping hazard
  - Chairs on castors – incorrect not generally a tripping hazard
20. \_\_\_\_\_ are a great invention keeping kitchens safe to use.
- Induction cooktops – correct, this eliminates knobs that might be easily bumped to initiate gas flow.**
  - Wall mounted pot sprayers – incorrect, not necessary for kitchen safety
  - Drop-in sinks with knee space – incorrect, not necessary for kitchen safety
  - Shorter bar stools – incorrect, not necessary for kitchen safety
21. There should always be \_\_\_\_\_ on counters next to appliances.
- Open work space – correct, this is important to have next to appliances**
  - Racks for commonly used dishes – incorrect, not needed on counters next to appliances
  - Backdraft exhaust hoods – incorrect, not needed on counter next to appliances
  - Medication dispensers – incorrect, not needed on counter next to appliances
22. \_\_\_\_\_ is the item in kitchens most often needing to be replaced for reasons of safety.
- The flooring – incorrect, flooring is not what most often needs to be replaced in the kitchen for safety reasons.
  - The stove – correct, If replacing a stove or oven is an option, avoid gas appliances. Electric or better yet, induction cooktops, are much safer. If dementia is a concern, a lockable cover or kill switch can be installed, with the switch hidden somewhere it is not obvious. A downdraft feature can be incorporated to draw heat away from the user.**
  - The water mixing valve; incorrect, not what most often needs to be replaces in the kitchen
  - The gas shut-off valve; incorrect, not what most often needs to be replaced in the kitchen for safety reasons.
23. The top of an accessible toilet should be between \_\_\_\_\_ and \_\_\_\_\_ inches.
- 14, 16 – incorrect, it should be 17 and 19 inches
  - 15, 17 – incorrect, it should be 17 and 19 inches
  - 16, 18 – incorrect, it should be 17 and 19 inches
  - 17, 19 – correct, the top of an accessible toilet should be between 17 and 19 inches.**

24. \_\_\_\_\_ should be provided in any space where standing water can occur.
- Water absorptive flooring – incorrect, this would cause mold
  - A floor drain - incorrect
  - Epoxy grout in joints - incorrect
  - Slip resistant flooring – correct, when considering slip resistance, using smaller tiles with more grout lines creates more slip resistance than using larger tiles.**
25. There should be \_\_\_\_\_ between a bedroom and a bathroom to be used.
- A clear line of sight – correct, this is essential for safety in the bedroom**
  - Hard surfaced flooring – incorrect, not needed in a bedroom
  - No place for a pet to lie – incorrect, you can find a place for your pet
  - Less than four steps – incorrect, you just need to be able to see where the bathroom is
26. If front loading laundry appliances are used, they should be raised off the floor \_\_\_\_\_.
- On recessed pedestals – incorrect, they should be raised off the floor between 12-15 inches
  - Between 12-15 inches – correct, they should be put on a base or platform from the manufacturer to raise them**
  - No more than 24 inches – incorrect, between 12 – 15 inches is correct
  - High enough to create knee space below – incorrect, they should be raised off the floor between 12-15 inches
27. Which of the following is not needed on stairs and ramps?
- Runs in one direction only – correct, this is not needed**
  - Handrails on both sides – incorrect, this is needed on stairs and ramps
  - Adequate lighting – incorrect, this is needed on stairs and ramps
  - Non-slip surface – incorrect, this is needed on stairs and ramps
28. \_\_\_\_\_ tend to be used in residences, rather than full size elevators.
- Escalators – incorrect, escalators use too much space and not good for elderly
  - Open lifts – incorrect, not what is usually used in residences
  - Limited use elevators – correct, what is typically used in residences**
  - Dumbwaiters – incorrect, not what is typically used in residences
29. \_\_\_\_\_ should be used at edges where a level change is occurring in flooring
- Audible alarms – incorrect, not used for level changes in flooring
  - A change in flooring color – correct, level changes in flooring presents hazards**
  - Two handrails with space to walk between - incorrect, not needed for every level change
  - Strips of reflective tape – incorrect, not needed for every level change as some level changes are just an 1/8 of an inch
30. When carrying baskets, a door type permitting hands-free entry is a \_\_\_\_\_.
- Double swinging door – correct, best for a hands free entry**
  - Pocket door – incorrect, have to use your hands for this type of door
  - Barn door – incorrect, typically have to use your hands for this type of door
  - Bi-pass door – incorrect, typically have to use your hands for this type of door