

Introduction

Parker HR Series Metering Valves provide the highest degree of precision metering for moderate pressure applications. A choice of seven precision ground, tapered flat, non-rotating and non-rising valve stems enable repeatable metering at flow capacities as low as 0.0004 C_V . With 15 stem turns, this valve offers the ultimate in precision flow control. This series also features shut-off capability not found in most metering valves.

Features

- ▶ Bubble tight shut-off
- ▶ Special fine pitch thread with 15 turn resolution is isolated from contact with process fluids
- ▶ Non-rotating/non-rising valve stem design provides smooth, non-reversing flow characteristics
- ▶ Seven optional valve stem tapers
- ▶ Special orifice liner assures long life
- ▶ Panel or in-line mounting
- ▶ Angle or in-line patterns
- ▶ Brass or 316 SS forged body construction
- ▶ 100% function tested for actuation and shut-off

Specifications

Pressure Rating at all temperatures:

..... 250 psig (17 bar) CWP

Flow Data*:

H0	Orifice: 0.000002 in ²
.....	In-line pattern: $C_V = 0.00034$; $X_T = 0.85$
.....	Angle pattern: $C_V = 0.00034$; $X_T = 0.66$
H1	Orifice: 0.000083 in ²
.....	In-line pattern: $C_V = 0.0008$; $X_T = 0.85$
.....	Angle pattern: $C_V = 0.0008$; $X_T = 0.66$
H2	Orifice: 0.000168 in ²
.....	In-line pattern: $C_V = 0.0014$; $X_T = 0.85$
.....	Angle pattern: $C_V = 0.0014$; $X_T = 0.66$
H3	Orifice: 0.000241 in ²
.....	In-line pattern: $C_V = 0.0031$; $X_T = 0.85$
.....	Angle pattern: $C_V = 0.0031$; $X_T = 0.66$
H4	Orifice: 0.000674 in ²
.....	In-line pattern: $C_V = 0.0077$; $X_T = 0.85$
.....	Angle pattern: $C_V = 0.0077$; $X_T = 0.66$
H5	Orifice: 0.002325 in ²
.....	In-line pattern: $C_V = 0.0300$; $X_T = 0.85$
.....	Angle pattern: $C_V = 0.0300$; $X_T = 0.66$
H6	Orifice: 0.006227 in ²
.....	In-line pattern: $C_V = 0.0900$; $X_T = 0.85$
.....	Angle pattern: $C_V = 0.0900$; $X_T = 0.66$

Turns to open: 15 +/- 1

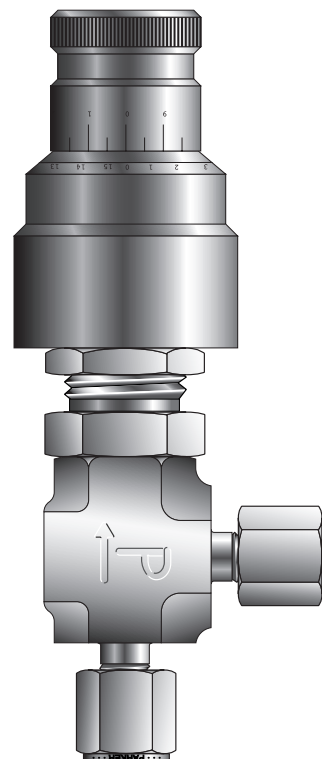

Model Shown: 2A-H0A-NE-SS-TC

Valve / Seal Temperature Ratings

Nitrile Rubber:..... -10°F to 250°F (-23°C to 121°C)

Ethylene Propylene Rubber:

..... -40°F to 250°F (-40°C to 121°C)

Neoprene Rubber:..... -40°F to 250°F (-40°C to 121°C)

Fluorocarbon Rubber:

..... -10°F to 400°F (-23°C to 204°C)

Highly Fluorinated Fluorocarbon Rubber:

..... -25°F to 200°F (-32°C to 93°C)

*Flow tested in accordance with ISA S75.02. Gas flow will be choked when $P_1 - P_2 / P_1 = x_T$.

**The Turns Counter Handle (TC) requires the HT option for use at temperatures above 300°F (149°C).

HR Series Dimensions

Dimensions in inches/millimeters are for reference only, subject to change.

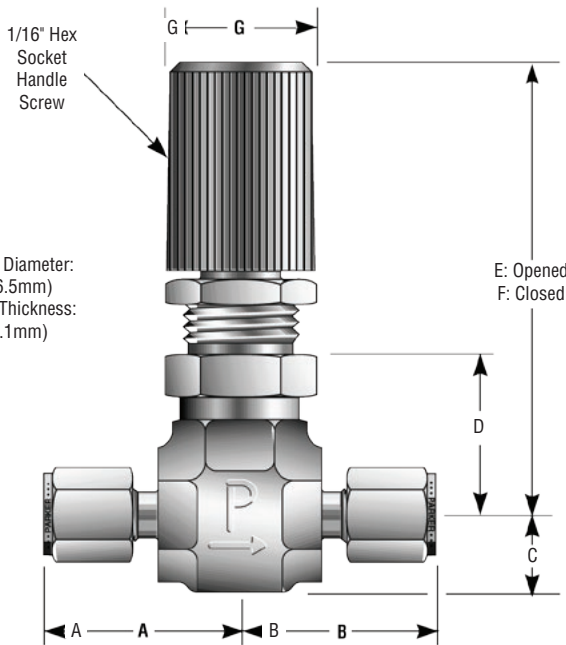

Panel Hole Diameter:
0.65 (16.5mm)
Max Panel Thickness:
0.28 (7.1mm)

**Model Shown:
4A-H6L-KZ-SS-K**

HR

Basic Part Number	End Connections		Dimensions							
	(Inlet) Port 1	(Outlet) Port 2	A†		B†		C		D	
			inch	mm	inch	mm	inch	mm	inch	mm
1A-H#A	1/16" Compression A-LOK®		0.92	23.4	0.92	23.4	0.41	10.4	0.73	18.5
1Z-H#A	1/16" Compression CPI™		0.92	23.4	0.92	23.4	0.41	10.4	0.73	18.5
2A-H#L	1/8" Compression A-LOK®		1.03	26.2	1.03	26.2	0.41	10.4	0.85	21.6
2A-H#A			1.03	26.2	1.03	26.2	0.41	10.4	0.73	18.5
2F-H#L	1/8" Female NPT		0.93	23.6	0.93	23.6	0.41	10.4	0.85	21.6
2F-H#A			0.93	23.6	0.93	23.6	0.41	10.4	0.73	18.5
2Z-H#L	1/8" Compression CPI™		1.03	26.2	1.03	26.2	0.41	10.4	0.85	21.6
2Z-H#A			1.03	26.2	1.03	26.2	0.41	10.4	0.73	18.5
4A-H#L	1/4" Compression A-LOK®		1.11	28.2	1.11	28.2	0.41	10.4	0.85	21.6
4A-H#A			1.11	28.2	1.11	28.2	0.41	10.4	0.73	18.5
4F-H#L	1/4" Female NPT		0.97	24.6	0.97	24.6	0.41	10.4	0.85	21.6
4F-H#A			0.97	24.6	0.97	24.6	0.41	10.4	0.73	18.5
4M-H#L	1/4" Male NPT		0.93	23.6	0.93	23.6	0.41	10.4	0.85	21.6
4M-H#A			0.93	23.6	0.93	23.6	0.41	10.4	0.73	18.5
4Z-H#L	1/4" Compression CPI™		1.11	28.2	1.11	28.2	0.41	10.4	0.85	21.6
4Z-H#A			1.11	28.2	1.11	28.2	0.41	10.4	0.73	18.5
M3A-H#L	3mm Compression A-LOK®		1.00	25.4	1.00	25.4	0.41	10.4	0.85	21.6
M3A-H#A			1.00	25.4	1.00	25.4	0.41	10.4	0.73	18.5
M3Z-H#L	3mm Compression CPI™		1.00	25.4	1.00	25.4	0.41	10.4	0.85	21.6
M3Z-H#A			1.00	25.4	1.00	25.4	0.41	10.4	0.73	18.5
M6A-H#L	6mm Compression A-LOK®		1.15	29.2	1.15	29.2	0.41	10.4	0.85	21.6
M6A-H#A			1.15	29.2	1.15	29.2	0.41	10.4	0.73	18.5
M6Z-H#L	6mm Compression CPI™		1.15	29.2	1.15	29.2	0.41	10.4	0.85	21.6
M6Z-H#A			1.15	29.2	1.15	29.2	0.41	10.4	0.73	18.5

† For CPI™ and A-LOK®, dimensions are measured with nuts in the finger tight position.

Handle Dimensions

	On In-Line Pattern Valves						On Angle Pattern Valves					
	K		TC		NS		K		TC		NS	
	inch	mm	inch	mm	inch	mm	inch	mm	inch	mm	inch	mm
E	2.35	59.7	2.88	73.2	2.33	59.2	2.23	56.6	2.76	70.1	2.21	56.1
F	2.35	59.7	2.88	73.2	2.33	59.2	2.23	56.6	2.76	70.1	2.21	56.1
G	0.78	19.8	1.12	28.4	0.25	6.4	0.78	19.8	1.12	28.4	0.25	6.4

Dimensions in inches/millimeters are for reference only, subject to change.



Materials of Construction

HR

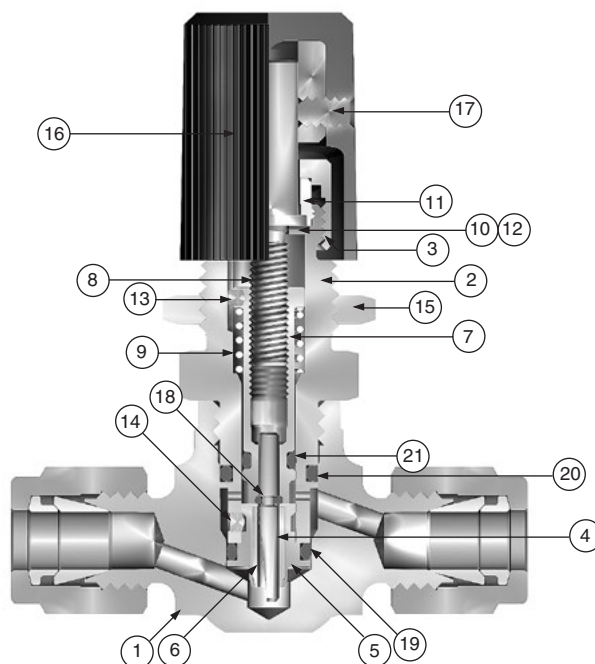

Model Shown: 4A-H4L-NE-SS-K

Item #	Description	Stainless Steel	Brass
1	Body	ASTM A 182 Type F316	ASTM B 283 Alloy C37700 (Nickel Plated)
2	Bonnet	ASTM A 479 Type 316	ASTM B 16 Alloy C36000 (Nickel Plated)
3	Bonnet Nut	ASTM B 16 Alloy C36000	ASTM B 16 Alloy C36000
4	Lower Stem	316 Stainless Steel	316 Stainless Steel
5	Orifice	ASTM A 479 Type 316	ASTM B 453 Alloy C34000
6	Orifice Liner	Mica-Filled PTFE	Mica-Filled PTFE
7	Stem Guide	ASTM A 182 Type F316	ASTM B 16 Alloy C36000
8	Upper Stem	ASTM B 150 Alloy C64200	ASTM B 150 Alloy C64200
9	Spring	302 Stainless Steel	302 Stainless Steel
10	Wave Washer	Steel	Steel
11	Friction Collar*	Acetal	Acetal
12	Stem Washer	Nylon	Nylon
13	Stem Guide Pin	Alloy Steel	Alloy Steel
14	Orifice Screw	Stainless Steel	Stainless Steel
15	Panel Nut	ASTM B 16 Nickel Plated)	ASTM B 16 (Nickel Plated)
16	Handle**	ABS Plastic	ABS Plastic
17	Handle Set Screw	Alloy Steel	Alloy Steel
18	Lower Stem O-Ring***	Fluorocarbon Rubber	Fluorocarbon Rubber
19	Orifice O-Ring***	Fluorocarbon Rubber	Fluorocarbon Rubber
20	Bonnet O-Ring***	Fluorocarbon Rubber	Fluorocarbon Rubber
21	Stem Guide O-Ring***	Fluorocarbon Rubber	Fluorocarbon Rubber

* Friction Collar is Polymide with HT option.

** Acrylonitrile-Butadiene-Styrene. Optional handles are available.

***Optional materials are available – See [How to Order](#).

Lubrication: Perfluorinated polyether.

C_v vs. Turns Open

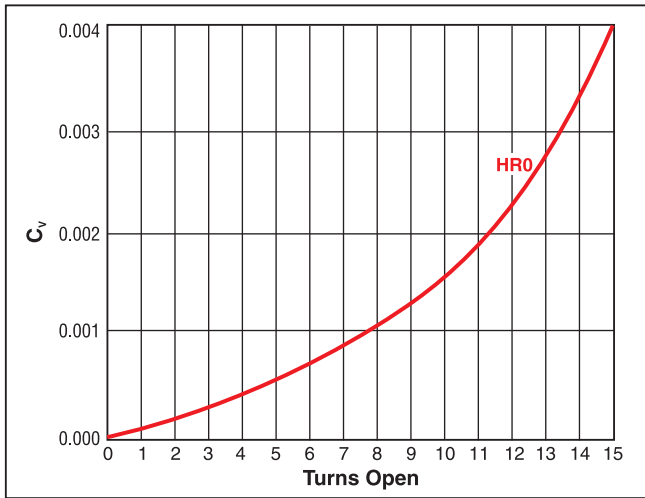

Water Flow Data

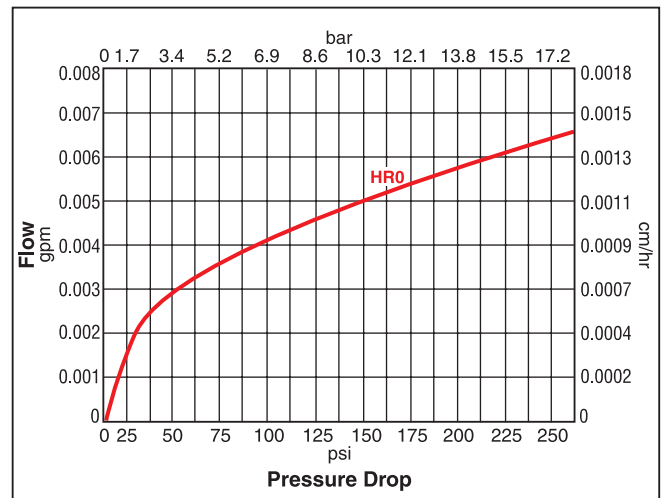

HR

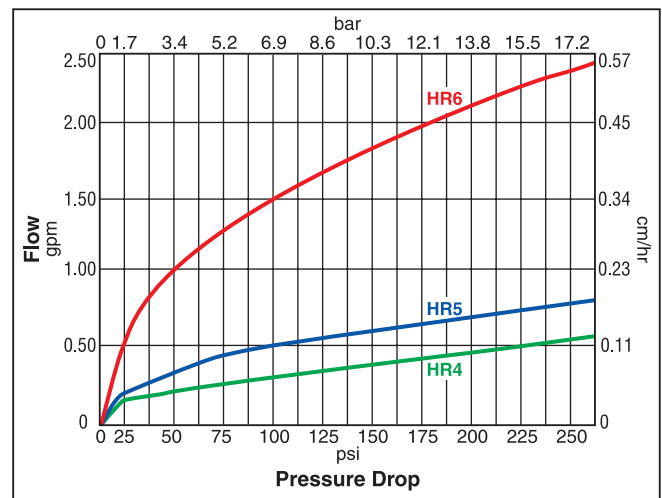
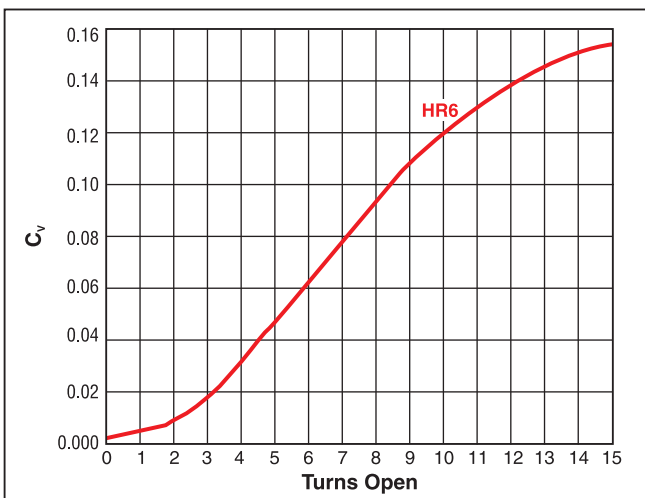
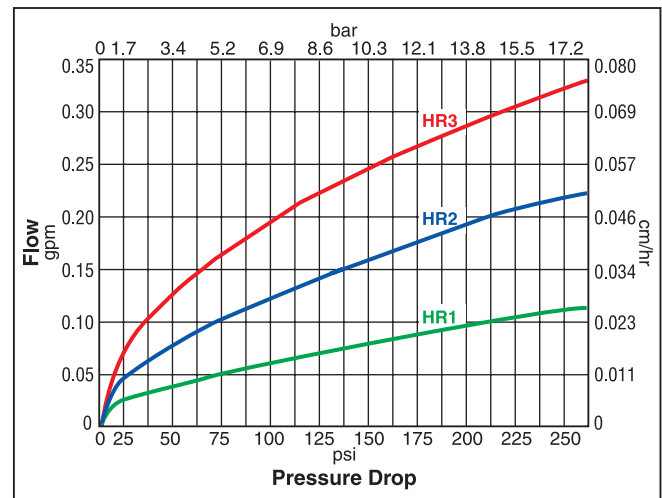
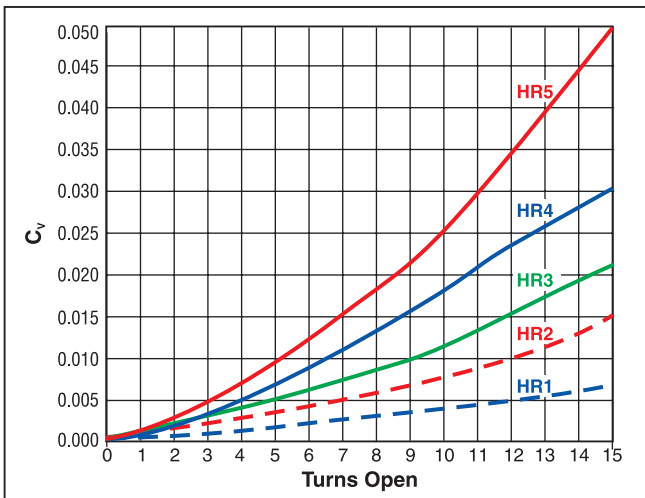

How to Order

Dimensions in inches/millimeters are for reference only, subject to change.

The correct part number is easily derived from the following example and ordering chart. The six product characteristics required are coded as shown in the chart.

The example below describes a stainless steel H3L in-line series valve with 1/4" CPI compression ends, fluorocarbon seals and vernier handle. "3" indicates a C_v of 0.200 per page 8.

Example: 4Z-H3L-V-SS-TC

4Z		H3L		V	SS	TC
Port 1	Port 2	Valve/Stem Series		Seal Material	Body Material	Handle Type
Inlet Port	Outlet Port	Valve/Stem Series**		Seal Material		Handle Type
1A, 1Z		H#A		BN	Nitrile Rubber	K Knurled TC Turns Counter
				EPR	Ethylene Propylene Rubber	
2A, 2F, 2Z, 4A, 4F, 4M, 4Z, M3A, M3Z, M6A, M6Z		H#A H#L		NE	Neoprene Rubber	NS No Handle (Slotted Stem)
				V	Fluorocarbon Rubber	
				KZ	Highly Fluorinated Fluorocarbon Rubber	

* If the inlet and outlet ports are the same, eliminate the outlet port designator.

** See flow data specifications on [page 8](#) to fully identify the valve/stem series properly.

Handle Options

Knurled (K)



Knurled ABS molded handle provides ease of actuation

Turns Counter (TC)

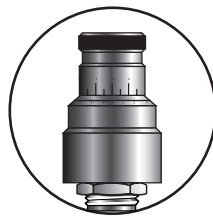

Graduated black-anodized aluminum alloy handle provides a readable count of turns open

Slotted Stem (NS)

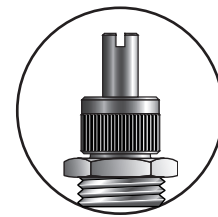

Screwdriver slot on top of stem may be used for inaccessible locations or tamper resistance

How to Order Options

Oxygen Cleaning – Add the suffix **-C3** to the end of the part number to receive valves cleaned and assembled for oxygen service in accordance with Parker Specification ES8003. **Example:** 4A-H1A-EPR-SS-K-C3

High Temperature – Add the suffix **-HT** to the end of the part number to receive valves with Turns Counter (TC) handles suitable for service above 300°F (149°C). **Example:** M3A-H4L-KZ-SS-TC-HT

Available End Connections

Standard End Connections

A - Two ferrule A-LOK®
compression port



Z - Single ferrule CPI™
compression port



F - ANSI/ASME B1.20.1
internal pipe threads



M - ANSI/ASME B1.20.1
external pipe threads



End
Conn

Non-Standard End Connections

F5 - SAE J1926/2, Part 2:
Heavy-duty (S Series) stud ends



G5 - SAE J1926/1, Part 1:
Threaded port with O-ring seal in
truncated housing

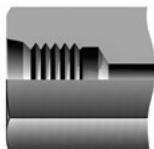

L - SAE J1453, Fitting – O-ring
face seal – External thread with
O-ring groove designed to seal with an
elastomer against a sleeve



KF - British Standard BS 21
(ISO 7-1), Internal pipe threads

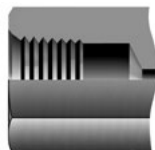

KM - British Standard BS 21
(ISO 7-1), External pipe threads



Q - UltraSeal face seal port



V - VacuSeal face seal port

