



2700 Series

Dekorón® Self-Regulating Heating Cable

Heat Trace Products, LLC



233 Florence Street
Leominster, MA 01453

ISO 9001 REGISTERED

Construction

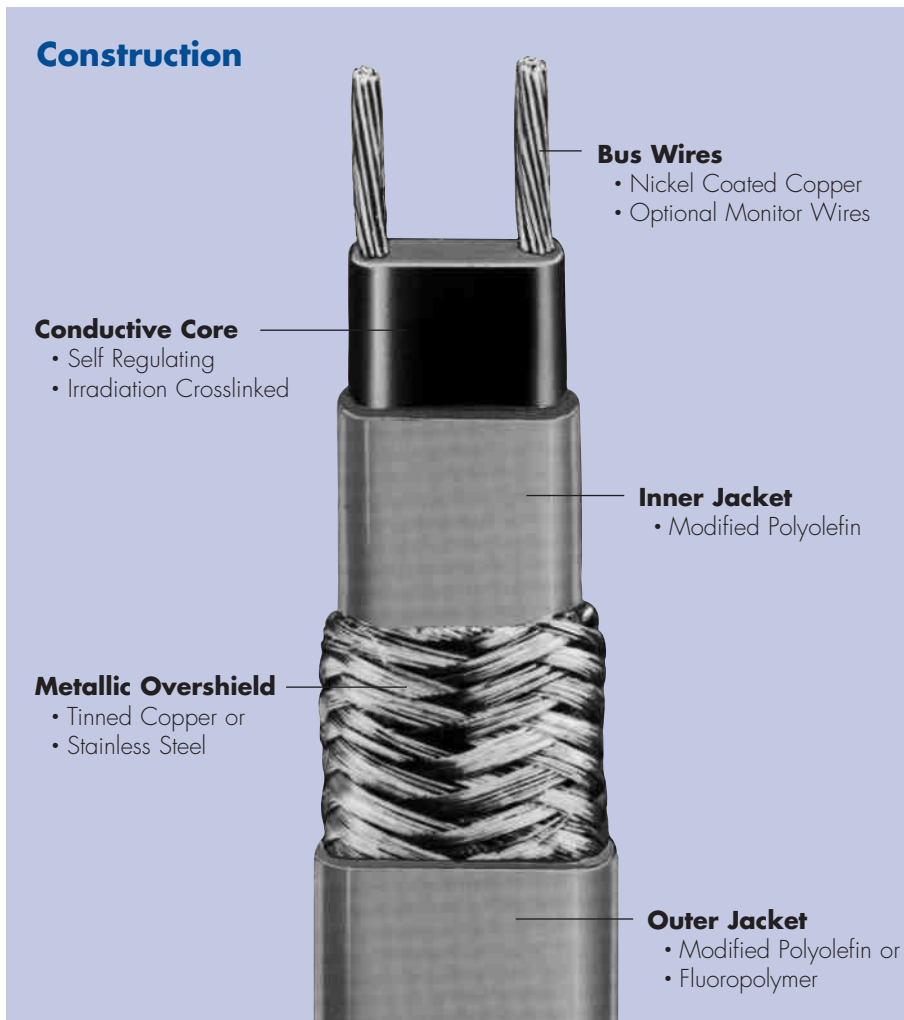

Description

The 2700 series of self-regulating heating cables are designed to supply a specified amount of heat at any point along their length in direct response to local temperature variations. These cables can maintain temperatures up to 150°F (65°C) and survive intermittent exposure up to 185°F (85°C) with power applied.

2700 cables can be cut to length and terminated in the field, and will not overheat or burnout when overlapped.

Applications

The industrial grade 2700 cables provide freeze protection and process temperature maintenance for fluid transport and storage systems. The bus wires, jackets and metallic braids can be configured for both ordinary (non-classified) and hazardous (classified) locations, including areas where exposure to corrosive or organic materials is possible.

Performance Ratings

Output wattage:

3, 5, 8, 10 w/ft @ 50°F

Supply voltages:

110 - 120 or 208V - 277Vac

Continuous maintenance temperature:

150°F (65°C) max

Intermittent exposure temperature:

185°F (85°C) max

T Rating*:

T-5 (10 w/ft), T-6 (3, 5, 8 w/ft)

Braid resistance:

Tinned copper: 0.003 Ω/ft
Stainless steel: 0.125 Ω/ft

*T-Rating per the 1999 NEC, Tables 500-5(d) and verified by FM and CSA.

Approvals/Certifications

Factory Mutual:

Ordinary locations

Hazardous locations

Class I, Div 1* / 2, Groups B, C, D

Class II, Div 2, Groups F, G

Class III, Div 1* and 2

CSA:

Ordinary locations STD. 130-03, -G, -W, -S

Hazardous locations

Class I, Div 1* / 2, Groups A,B,C,D

Class II, Div 1* / 2, Groups E, F, G

Class III, Div 1* and 2

UL:

Roof and Gutter

Hot Water Maintenance

SEMCO - (CE mark):

*Contact Heat Trace Products representative for information on Division I hazardous location systems.

Accessories

Heat Trace Products carries a full line of approved accessories, including power connection kits, terminations, splices, end seals, and controls.

Visit Us At: www.rsc-heattrace.com

Heat Trace Products, LLC • 233 Florence Street • Leominster, MA 01453 • Tel: 978-534-2810 • Fax: 978-534-2819

Buy: www.ValinOnline.com | Phone 844-385-3099 | Email: CustomerService@valin.com





Heat Trace Products, LLC



233 Florence Street
Leominster, MA 01453

ISO 9001 REGISTERED

2700 Series

Dekoron® Self-Regulating Heating Cable

Power Output Curves - 2700 Series

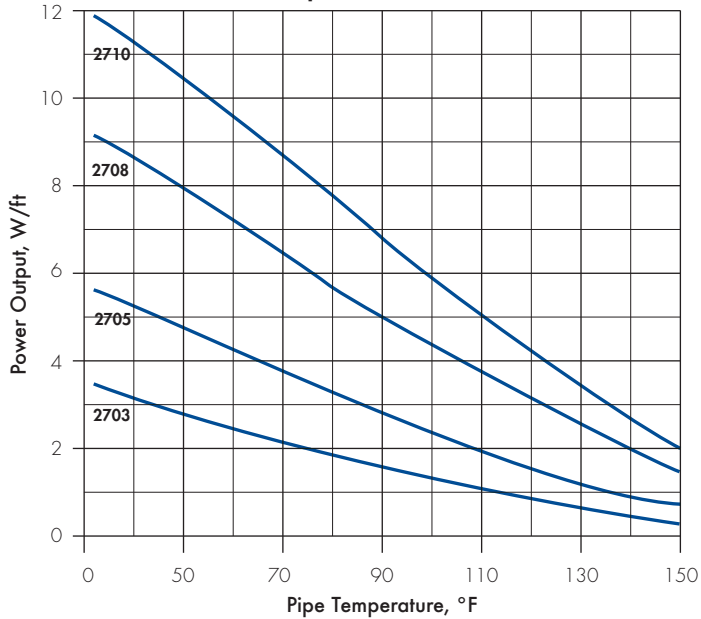

Product Ordering Information

(Example Shown: 5 watt 120volt, tinned copper braid)

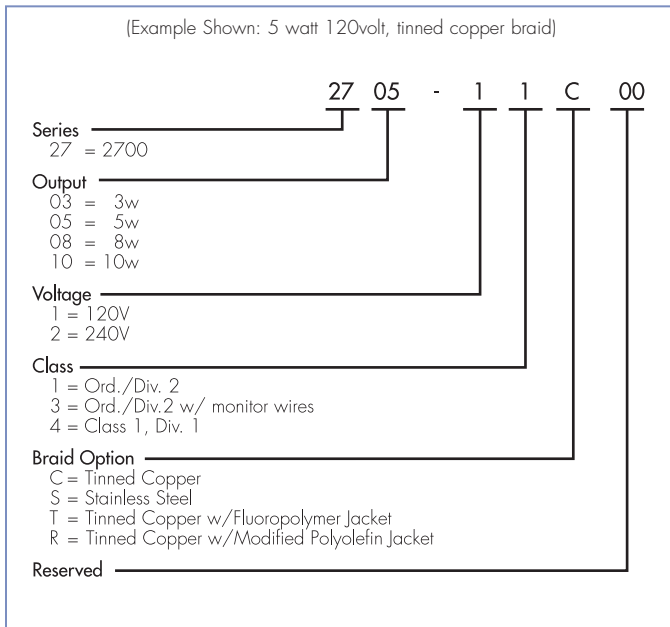

120 Volt Breaker Sizing vs. Max Circuit Length (FT)

| | 15A | 20A | 30A | 40A |
|----------------------------|-----|-----|-----|-----|
| 2703-1 If started at: 50°F | 300 | — | — | — |
| 0°F | 200 | 270 | 330 | — |
| -20°F | 180 | 230 | 330 | — |
| 2705-1 If started at: 50°F | 230 | 270 | — | — |
| 0°F | 150 | 200 | 270 | — |
| -20°F | 130 | 175 | 260 | 270 |
| 2708-1 If started at: 50°F | 150 | 200 | 210 | — |
| 0°F | 95 | 125 | 190 | 210 |
| -20°F | 85 | 100 | 170 | 210 |
| 2710-1 If started at: 50°F | 115 | 150 | 180 | — |
| 0°F | 70 | 95 | 145 | 180 |
| -20°F | 60 | 85 | 120 | 165 |

240 Volt Breaker Sizing vs. Max Circuit Length (FT)

| | 15A | 20A | 30A | 40A |
|----------------------------|-----|-----|-----|-----|
| 2703-2 If started at: 50°F | 660 | — | — | — |
| 0°F | 410 | 560 | 660 | — |
| -20°F | 360 | 480 | 660 | — |
| 2705-2 If started at: 50°F | 460 | 540 | — | — |
| 0°F | 300 | 400 | 540 | — |
| -20°F | 260 | 345 | 520 | 540 |
| 2708-2 If started at: 50°F | 295 | 390 | 420 | — |
| 0°F | 195 | 250 | 375 | 420 |
| -20°F | 170 | 225 | 340 | 420 |
| 2710-2 If started at: 50°F | 230 | 305 | 360 | — |
| 0°F | 150 | 200 | 300 | 360 |
| -20°F | 130 | 175 | 260 | 360 |

NOTE: Recommended circuit breakers to minimize the effect of transit start-up currents.

Westinghouse: Types BA, EB, EHB, FB, HFB. **General Electric:** E100 Type TEB, E150, Types TED, THED. **Square D:** Types EH, FAIF. The National Electric Code requires ground fault protection of equipment for each branch circuit supplying electrical heating cables or devices.

Power Adjustment Factor

| Part No. | 208 Volts | 277 Volts |
|----------|-----------|-----------|
| 2703-2 | .75 | 1.28 |
| 2705-2 | .86 | 1.16 |
| 2708-2 | .91 | 1.10 |
| 2710-2 | .93 | 1.08 |

The material contained in this document is presented in good faith and believed to be reliable and accurate. However, because testing conditions may vary and material quality or information that may be provided in whole or in part by others may be beyond our control, no warranty expressed or implied, is given and Heat Trace Products, LLC can assume no liability for results obtained or damages incurred through the application of the data and tests presented.

ISO 9001 REGISTERED

Heat Trace Products, LLC



ISO 9001 REGISTERED

233 Florence Street
Leominster, MA 01453
Tel: 978 534-2810
Fax: 978-534-2819
www.rssc-heattrace.com

