

Relio™ R1 Rugged Industrial Computer

User Manual | Relio™ R1 Rugged



SEALEVEL®

Contents

CONTENTS	2
INTRODUCTION	4
OVERVIEW	4
FEATURES	5
BEFORE YOU GET STARTED	6
WHAT'S INCLUDED	6
ADVISORY CONVENTIONS	6
OPTIONAL ITEMS	6
<i>Cables</i>	7
<i>Loopback Adapters</i>	8
<i>Power Supply</i>	8
TECHNICAL DESCRIPTION	9
R1 RUGGED PART NUMBER BREAKDOWN	9
SAMPLE OF ORDERABLE R1 RUGGED PART NUMBERS	9
SYSTEM DESCRIPTION	9
COM EXPRESS MODULE/RAM CONFIGURATION OPTIONS	10
SATA CFAST TYPE I, II MEMORY	10
POWER INPUT	11
DIGITAL VIDEO OUTPUT	12
ETHERNET	12
SERIAL COMMUNICATIONS	12
<i>RS-232/485 Serial Ports</i>	12
<i>RS-485 Termination Resistors</i>	12
<i>RS-232/485 Port 1 and RS-232/485 Port 2</i>	13
USB 2.0 DEVICE AND USB 3.1 DEVICE	13
CAN OPERATION	14
WI-FI OPERATION	15
CAD REFERENCES	15
ISOMETRIC VIEW	15
FRONT PANEL I/O CONNECTORS	16
RIGHT PANEL I/O CONNECTORS	16
LEFT PANEL I/O CONNECTORS	17
SYSTEM SET-UP	17
HARDWARE INSTALLATION	18
INSTALLATION CONSIDERATIONS	18
SOFTWARE INSTALLATION	19
CONGATEC DRIVERS AND MODULE INFORMATION	19

ETHERNET DRIVER	19
SERIAL PORTS	19
KVASER CAN CARD (LINUX AND WINDOWS).....	20
SILEX TECHNOLOGY WI-FI CARD (CONTACT THEIR SUPPORT DEPARTMENT FOR DRIVER AVAILABILITY)	20
SEACOM WINDOWS INSTALLATION.....	20
UPGRADING TO THE CURRENT SEACOM DRIVER.....	22
TECHNICAL SPECIFICATIONS ENVIRONMENTAL SPECIFICATIONS.....	23
MECHANICAL DIMENSIONS.....	23
POWER CONSUMPTION	23
MANUFACTURING.....	23
MTBF (TELCORDIA SR-332, ISSUE 4 CALCULATION PREDICTION METHOD).....	23
OPERATING TEMPERATURE RANGE	24
SYSTEM OPERATION.....	24
POWER AND RESET AND BUTTONS	24
HIGH PERFORMANCE SERIAL COMMUNICATION PORTS.....	25
CLOCK MODES AND BAUD RATES	26
SERIAL INTERFACE SELECTION.....	26
<i>COM Port Configuration</i>	27
<i>RS-485 Enable Modes</i>	29
<i>Slew Rate Limiting</i>	29
<i>Receiver Biasing</i>	29
<i>Line Termination Selection via Hardware</i>	29
<i>RS-485 Auto-Enable Delay</i>	30
APPENDIX A – TROUBLESHOOTING SERIAL COMMUNICATION ISSUES.....	31
TROUBLESHOOTING/VERIFICATION FOR ASYNCHRONOUS SERIAL PRODUCTS	31
APPENDIX B – HOW TO GET ASSISTANCE.....	36
APPENDIX C – COMPLIANCE NOTICES.....	37
FEDERAL COMMUNICATIONS COMMISSION (FCC) STATEMENT	37
ISED CANADA	37
EMC DIRECTIVE STATEMENT	37
APPENDIX D - HANDLING INSTRUCTIONS.....	38
APPENDIX E – ELECTRICAL INTERFACE.....	39
RS-232.....	39
RS-485.....	39
APPENDIX F – ASYNCHRONOUS COMMUNICATIONS	40
WARRANTY	41

Introduction

Overview

The **Relio™ R1 Rugged Industrial Computer** is an exceptionally rugged embedded computer for operating in harsh environments. The R1 Rugged's fanless and nearly cableless structure ensures durability over long-term use. Built using the [PICMG COM Express architecture](#), Sealevel has partnered with the leading COM Express module manufacturers to ensure our customers benefit from the best in the industry.

The R1 Rugged is the latest addition to the industry-leading Relio embedded computer line. The R1 Rugged incorporates the newest generation of industrial processors and a modernized video interface. With versatile communication options for CAN, Wi-Fi, and RS-232/485, the R1 Rugged features (2) locking USB 3.1 ports, (2) locking USB 2.0 ports, (2) Gigabit Ethernet ports, and an extreme, wide operating temperature range of up to -40°C to +71°C.

The R1 Rugged has an extreme rugged, anodized aluminum enclosure combined with intentional thermal management for unmitigated performance under environmental extremes. The fanless, solid-state design, combined with locking SeaLATCH USB connectors, ensures shock and vibration tolerance as well as long-term reliability.

With a robust and flexible I/O mix, this rugged industrial computer is capable of managing a variety of data inputs to interface with legacy systems and the most advanced peripherals. The embedded computer's COM Express architecture gives manufacturers a technology migration path to easily change, and upgrade, the CPU functionality without a complete system redesign or replacement.

Inside the R1 Rugged, a CFAST SATA II card slot provides solid-state storage ranging from 64GB to 256GB. The R1 Rugged is compatible with Windows 10 IoT Enterprise, Windows 11 Pro, Linux RHEL 8 (or later), and Linux Ubuntu 21 (or later). The system is also Windows 11 IoT-ready to provide maximum flexibility for evolving, customer-specific software applications. Sealevel's SeaCOM hardware driver is included to support system I/O. Serial application code samples assist with custom application development and complete support documentation expedites configuration.

Features

- Up to -40°C to 71°C wide operating temperature range
- 18-36VDC input with locking 2-position connector
- (2) Gigabit (10/100/1000BaseT) Ethernet Ports
- (2) USB 3.1 SeaLATCH Charging Ports
- (2) USB 2.0 SeaLATCH Ports
- (1) Video DVI-D Port connector
- (1) Video DisplayPort connector
- (2) 2-wire RS-232/485 Ports
- (1) CFAST SATA SSD Interface
- 6.6" (L) x 5.0" (W) x 1.9" (H) dimensions
- (2) High-Speed Controller Area Network (HS-CAN) ports (optional)
- Wi-Fi 4 (optional)



- (1) Video DVI-D Port Connector
- (2) Gigabit (10/100/1000BaseT) Ethernet Ports
- (1) Video DisplayPort Connector
- (1) USB 3.1 SeaLATCH Charging Port



- (1) 18-36VDC input with Locking 2-Pos Connector
- (2) USB 3.1 SeaLATCH Charging Ports



HS-CAN Option

- (2) 2-wire RS-232/485 Ports
- (2) High-Speed CAN Ports
- (2) USB 2.0 SeaLATCH Ports
- (1) CFAST SATA SSD Interface

Before You Get Started

What's Included

The R1 Rugged is shipped with the following items. If any of these items are missing or damaged, please contact Sealevel for replacement.

- **Relio™ R1 Rugged Industrial Computer System**
- **2-POS terminal block for power input.**
- **Installation instructions including compliance and rating information**

Advisory Conventions



Warning

The highest level of importance used to stress a condition where damage could result to the product, or the user could suffer serious injury.



Important

The middle level of importance used to highlight information that might not seem obvious or a situation that could cause the product to fail.



Note



The lowest level of importance used to provide background information, additional tips, or other non-critical facts that will not affect the use of the product.

Optional Items



Depending upon your application, you are likely to find one or more of the following items useful with the R1 Rugged. All items can be purchased from our website (www.sealevel.com) or by calling our sales team at (864) 843-4343.

Cables

CAT5 Patch Cable, 7' In Length (Part# CA246)	
<p>Standard 7' CAT5 Unshielded Twisted Ethernet Pair Patch Cable (RJ45) with blue jacket.</p>	
CAT5 Patch Cable, 10' In Length (Part# CA247)	
<p>Standard 10' CAT5 Unshielded Twisted Pair Ethernet Patch Cable (RJ45) with blue jacket. USB 2.0, TYPE A SeaLATCH TO USB 2.0 TYPE B, 6 FT LONG</p>	
SeaLATCH USB 2.0 Type A to USB 2.0 Type B, 72" Length - Device Cable, (Part# CA355)	
<p>The CA355 is a 72" USB device cable with Sealevel's SeaLatch locking USB type A and type B connectors. The metal thumbscrew on each connector provides a secure metal-to-metal connection to devices with SeaLatch USB ports.</p>	
SeaLATCH USB Type A to USB Type B, 5 Meter Length - Device Cable (Item# CA355-5M)	
<p>The CA355-5M is a 5 meter (16 feet) USB device cable with Sealevel's SeaLatch locking USB type A connector and standard type B connector. The metal thumbscrew on the type A connector provides a secure metal-to-metal connection to devices with SeaLatch USB ports.</p>	
SeaLATCH USB Type A to SeaLATCH USB Type B, 72" Length - Device Cable, (Item# CA332)	
<p>The CA332 is a 72" USB device cable with Sealevel's SeaLatch locking USB type A and type B connectors. The metal thumbscrew on each connector provides a secure metal-to-metal connection to devices with SeaLatch USB ports.</p>	

SeaLATCH USB Type A to SeaLATCH USB Type B, 5 Meter Length - Device Cable (Item# CA332-5M)	
<p>The CA332-5M is a 5 meter (16 feet) USB device cable with Sealevel's SeaLatch locking USB Type A and B connectors. The metal thumbscrew on the type A connector ensures secure connection.</p>	
USB Type A to SeaLATCH USB Type B, 72" Length – Device Cable (Item# CA356)	
<p>The CA356 is a 72" USB device cable that securely connects USB device port (metal thumbscrew lock) to a host computer. The CA356 is USB 2.0 compliant and is compatible with USB 1.1 and 1.0 devices.</p>	

Loopback Adapters

DB9 Female Serial Loopback Adapter (Part# LB101)	
<p>The LB101 can be used to test any Sealevel serial device with a DB9 male connector. Only the data pins are looped back.</p>	
DB25 Female Serial Loopback Adapter (Part# LB102)	
<p>The LB102 can be used to test any Sealevel serial device with a DB25 male connector. Only the data pins are looped back.</p>	

Power Supply

100-240VAC to 24VDC @ 2.7A , Desktop Power Supply (Part# TR152)	
<p>The TR152 is a desktop (brick style) power supply rated for 100-240VAC input and 24VDC output at 2.7 amps. The cable has tinned leads for use with products that have screw terminals for input power.</p>	

Technical Description

R1 Rugged Part Number Breakdown

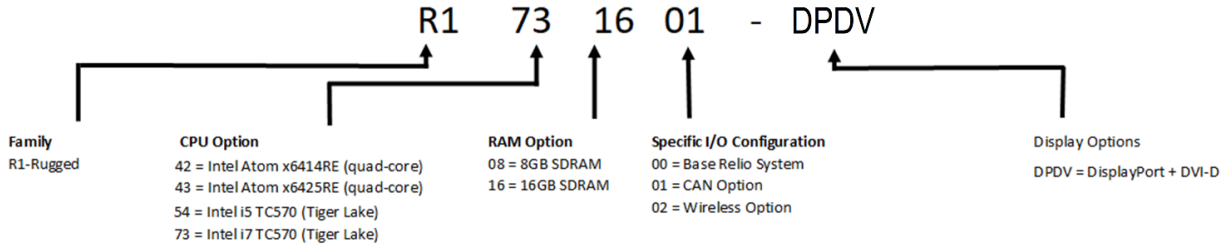

Sample of Orderable R1 Rugged Part Numbers

Part Number	COM Express Module	COM Express Module Description	RAM
R17316xx-DPDV	congatec TC570	Type 6 Compact Module with INTEL i7 1185GRE CPU	16GB DDR4 3200
R15416xx-DPDV	congatec TC570	Type 6 Compact Module with INTEL i5 1145GRE CPU	16GB DDR4 3200
R14316xx-DPDV	congatec TCA7	Type 6 Compact Module with INTEL ATOM 6425RE CPU	16GB DDR4 3200
R14208xx-DPDV	congatec TCA7	Type 6 Compact Module with INTEL ATOM 6414RE CPU	8GB DDR4 3200

System Description

The following I/O connectors use industry standard pin outs for maximum compatibility.

Function	Connector Type
Digital Video Output	DVI-D DisplayPort
10/100/1000 (Gigabit Ethernet) Network Connections	RJ45
RS-232 Serial Ports	3.5mm Terminal Block
USB 2.0 Device	USB Type A (High Retention)
USB 3.1 Device	USB Type A
Wi-Fi	Internal mPCIe
CAN	Internal mPCIe

COM Express Module/RAM Configuration Options

The R1 Rugged Industrial Computer is compatible with compact form factor Type 6 COM Express modules. COM Express is a widely supported implementation of Computer on Module (COM) design. The COM Express architecture reduces the complexity, cost and time required for computer system design by combining the processing, memory, video, Ethernet and USB functionality in a small, highly integrated module. COM Express modules install on a carrier board that provides the application specific I/O and external connectors best suited for the system requirements.

Our COM Express carrier boards leverage Sealevel's I/O and communication expertise, providing carrier board and full system solutions as rapidly as possible.

The R1 I/O Rugged Industrial Computer is available in a variety of configurations, see the Sealevel website for all configurations:

[Relio™ R1 Rugged Industrial Computers](#)

SATA CFAST Type I, II Memory

When power is removed from the R1 Rugged, the CFAST memory card inside can be replaced. To do this remove all screws from the side faceplate. The existing card can then be pulled from the port and a new card inserted. Reinstall the faceplate before connecting power to the device.

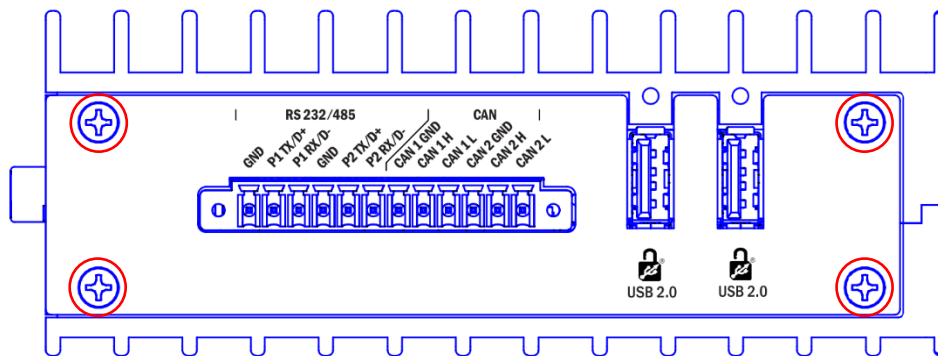

SATA CFAST Type I, II Memory Card Port

Power Input

The system is designed to operate from 18VDC up to 36VDC. The current draw varies across this range; it is heavily dependent on the COM Express module, peripheral devices and installed software. The main power input is via a 2-pos 5.08mm pluggable, locking connector (SL#104456). The power source must be appropriately listed ITE Power Supply Limited Power Source, or LPS, suitable for the maximum ambient temperature at the installation.

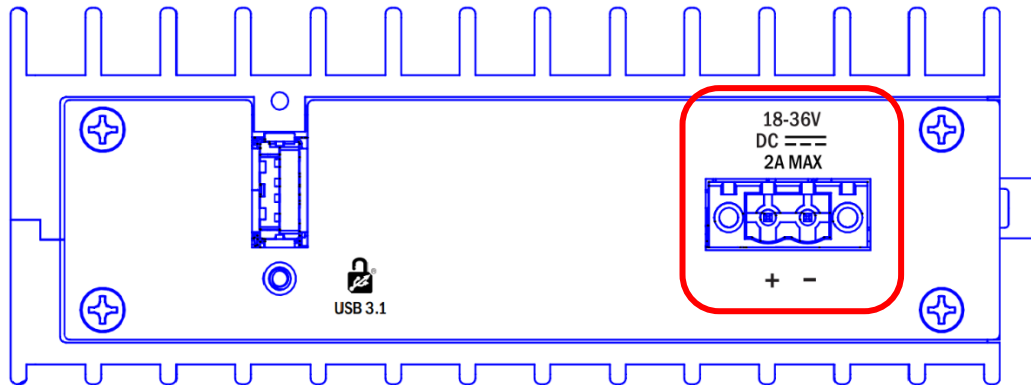

CKT #	Signal	Name
1	+	Positive DC Power
2	-	Negative DC Power (GND)

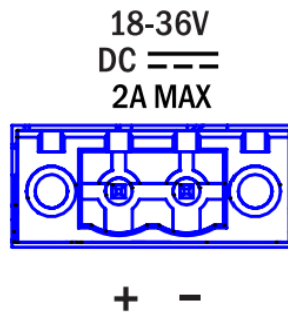

18-36VDC Input Power



If the computer must be located in an environment outside of 0°C to +40°C, ensure the power source that you will be using can supply the power listed over the operational temperature range.

Digital Video Output

The system has two video outputs: (1) DVI-D and (1) DisplayPort.

Ethernet

The system has two 10/100/1000 (Gigabit Ethernet) Network ports.

Serial Communications

You can connect to a variety of serial peripherals via the R1 Rugged serial ports. To start with, there are two configurable serial ports which are provided on both the 6 and 12 position 3.5mm pitch terminal blocks with screw retention. The serial ports are software configurable to add Termination across each data pair.

RS-232/485 Serial Ports

The system has two asynchronous serial ports that are configurable via the SeaCOM software driver to operate as RS-232, or RS- RS-485.

RS-485 Termination Resistors

Each RS-485 port has selectable termination via software configuration.

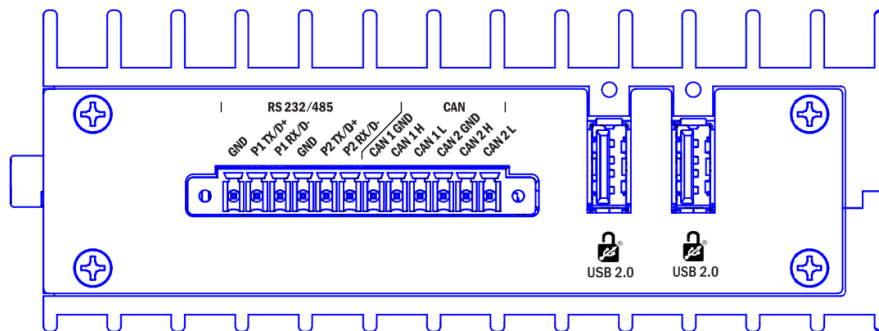

Description: 12 Position 3.5mm Terminal Block

RS-232/485 Port 1 and RS-232/485 Port 2

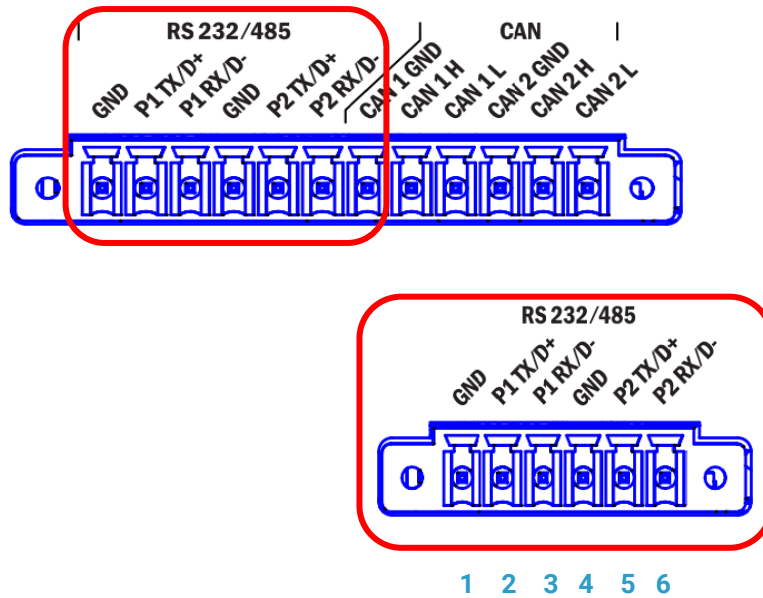

Serial Connector (6 Position):

6 Position SERIAL 3.5mm Terminal Block Pin Out		
PIN	RS-232	RS-485
1	GND	GND
2	TX 1	DATA+(I/O) 1
3	RX1	DATA-(I/O) 1
4	GND	GND
5	TX2	DATA+(I/O) 2
6	RX2	DATA-(I/O) 2

USB 2.0 Device and USB 3.1 Device

The USB 2.0 ports are equipped with high retention connectors that are designed with a minimum of 15 N withdrawal force. These connectors are indicated by an orange insert within the connector. For situations where accidental disconnection of the USB cable must be prevented, the system has three of the 6 USB 2.0 ports equipped for SeaLATCH USB cables. SeaLATCH cables have a thumbscrew that provides a secure metal-to-metal connection preventing accidental disconnection.

The system has two USB 3.1 port with SeaLATCH support. The USB 3.1 ports have a blue insert within the connector.

CAN Operation

The R1 Rugged can be ordered with an option to support either two High Speed Controller Area Network (HS-CAN) ports, or two Controller Area Network Flexible Data-Rate (CAN-FD) ports. This feature provides a CAN to PCIe connection in your choice of operating system. HS-CAN is capable of 1 Mbps data rates in a noisy party line environment, and CAN-FD is capable of 2Mbps. When ordered with this option, the R1 Rugged is preloaded with drivers for your selected operating system (Windows and Linux OS).

The R1 Rugged with Controller Area Network (CAN) feature has the following specs:

- (2) Isolated CAN Ports
- HS-CAN or CAN-FD
- 1 Mbits Max data rate
- PCIe
- Up to -40°C to 71°C wide operating temperature range

For more information about the CAN module please contact Sales.

12 Position SERIAL + CAN 3.5mm Terminal Block Pin Out			
PIN	RS-232	RS-485	CAN
1	GND	GND	
2	TX1	DATA+(I/O)1	
3	RX1	DATA-(I/O)1	
4	GND	GND	
5	TX2	DATA+(I/O) 2	
6	RX2	DATA-(I/O) 2	
7			CAN1-GND
8			CAN1 +
9			CAN1 -
10			CAN2-GND
11			CAN2 +
12			CAN2 -

Wi-Fi Operation

The R1 Rugged can be ordered with an option to support 802.11 a/ WLAN/ Wi-Fi communications. The Wi-Fi 4 module operates in the 2.4GHz and 5GHz frequency range and is capable of 300Mbps communication. When ordered with this option, the R1 Rugged is preloaded with drivers for both Windows and Linux OS.

The R1 Rugged with Wi-Fi (WLAN) feature has the following specs:

- PCIe Wi-Fi 4 module
- 802.11a/b/g/n
- 2.4GHz/5GHz
- 2x2 MIMO performance with 300Mbps data rate
- Up to -40°C to 71°C wide operating temperature range

For more information about the Wi-Fi module please contact Sales.

CAD References

Isometric View

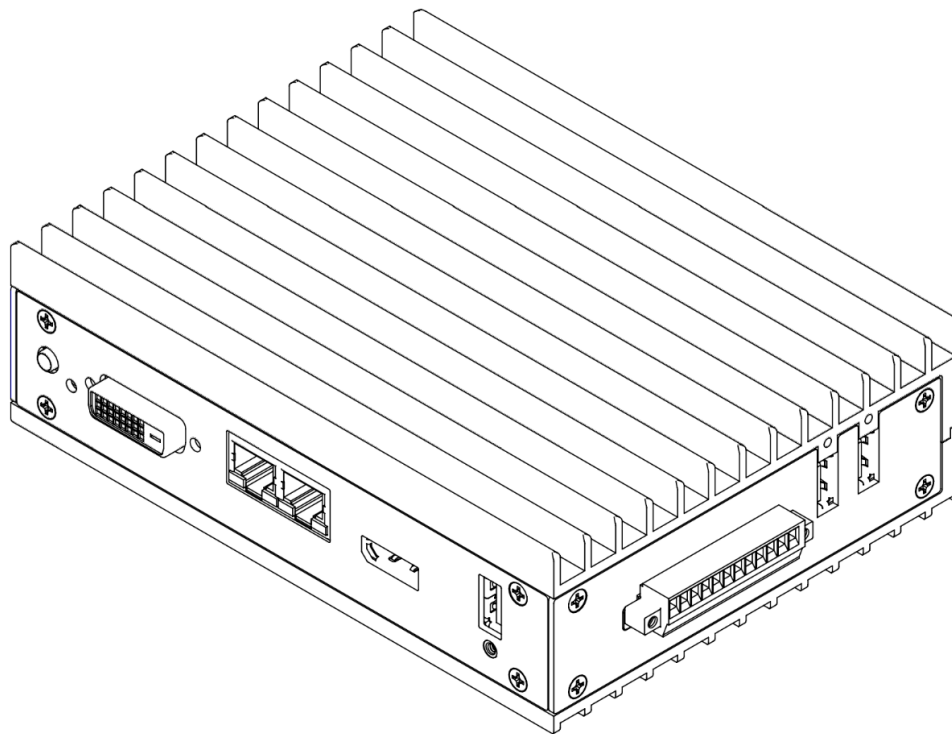

Front Panel I/O Connectors

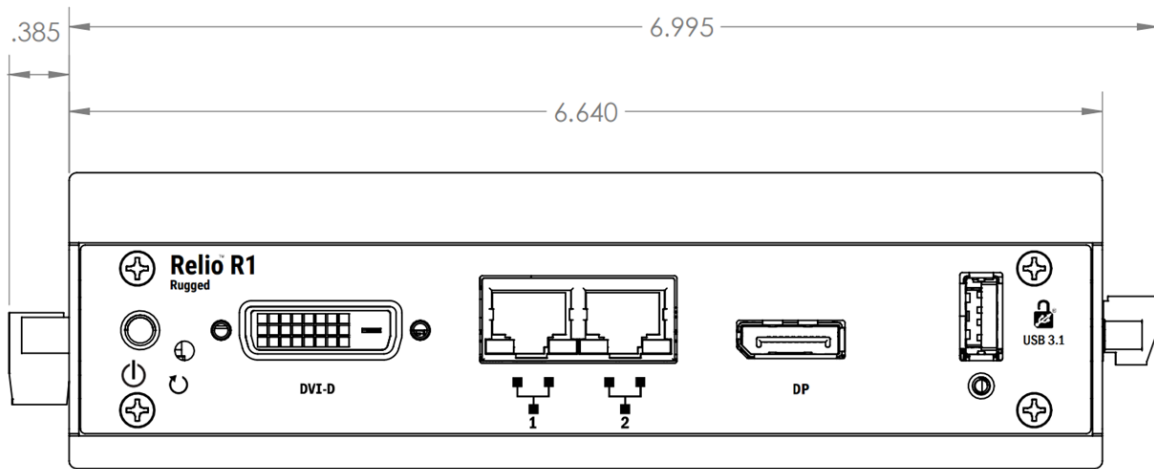

Right Panel I/O Connectors

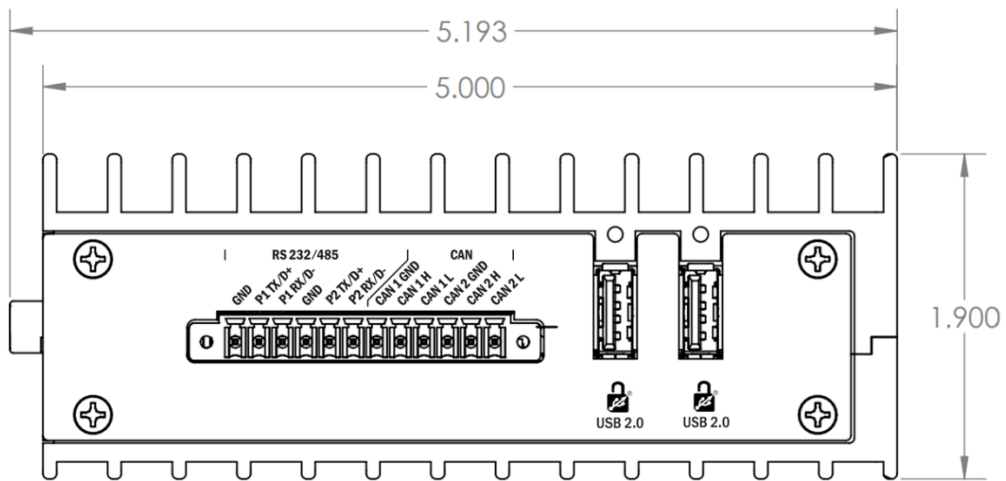

Left Panel I/O Connectors

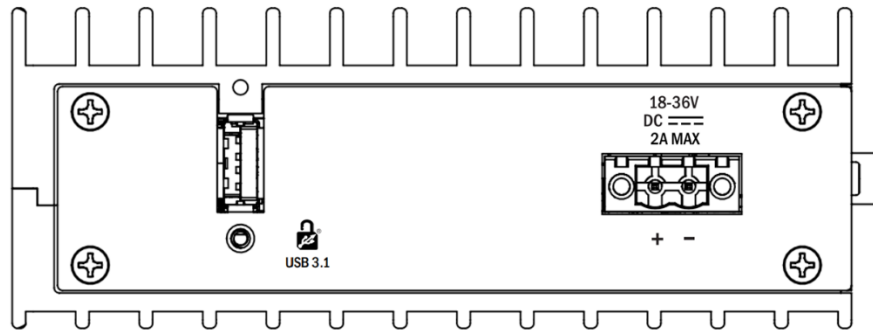

System Set-Up

The Base R1 Rugged Industrial Computer system does not include a solid-state drive or operating system. These are added at the time of purchase and will be installed by Sealevel's experienced technicians. The OS and all necessary software drivers are preinstalled at the factory.

If need to install the operating system yourself, you will also need to install the applicable drivers. Some drivers apply to the hardware on the COM Express module; some are for devices present on the carrier board. The following table lists the devices that will require drivers.

Device	Location	Driver Source
Chipset	COM Express Module	COM Express Module Manufacturer
Integrated Graphics	COM Express Module	COM Express Module Manufacturer
Network Connection 1	COM Express Module	COM Express Module Manufacturer
Network Connection 2	Carrier Board	Intel website
Serial Ports	Carrier Board	Sealevel website

Hardware Installation

For full installation instructions, please refer to the Installation Guide provided with your R1 Rugged. If you do not have the installation guide readily available, contact our sales team at sales@sealevel.com. They can also provide you with 3D model images, and compliance certifications for the R1 Rugged.

Installation Considerations

The R1 Rugged can operate without airflow at 50°C as long as the steady-state CPU usage does not exceed 50%. If CPU usage is sustained at a workload greater than 50%, the CPU will throttle itself back to keep its internal temperature in a safe range.

If the application environment requires the computer to operate at 50°C with steady state CPU usage greater than 50%, some additional cooling must be used to ensure safe operation of the electronics.

The R1Rugged Industrial Computer system is a fanless, solid state computer that relies on thermal conduction to move heat from internal components to the outside of the enclosure. The lid is designed as a finned heat sink to increase overall surface area. Three main cooling methods can be used to optimize removal of heat from the system.

1. Airflow
2. Thermal conduction through mounting
3. Computer orientation

Airflow over the lid provides the most effective heat removal of these three options. It is optimal to mount the computer in an area that has either natural or forced airflow to constantly remove heat from the enclosure.

Mounting the computer to a large thermally conductive surface (such as an I-Beam, steel cabinet or other large metal surface) allows heat to travel through the enclosure and be dissipated into the large structure.



- Only technically qualified personnel are permitted to install the equipment.
- Do not use the system with visible damage to any part of the unit or cable connection.
- Reduced Air Flow - Installation of the equipment should be such that the natural airflow around the equipment is not compromised.
- Thermal derating – Installation of the system in vertical orientation is preferred for thermal performance. Forced airflow or derating of the maximum operating temperature may need to be considered in horizontal mounting orientation.

Software Installation

At Sealevel Systems, we preinstall all required software needed for the R1 Rugged. If for some reason you need to reinstall any software or drivers, you can find what you need at the below links:

congatec Drivers and Module Information

The following table provides the COM Express module family for the different models of the R1 Rugged Industrial Computers.

Model	Manufacturer	Vendor Website	Module Family
R17316xx-DPDV	congatec	www.congatec.com	TC570
R15416xx-DPDV	congatec	www.congatec.com	TC570
R14316xx-DPDV	congatec	www.congatec.com	TCA7
R14216xx-DPDV	congatec	www.congatec.com	TCA7



The below links require a free congatec account.

Drivers and other information for the modules can be found here:

4. [congatec conga-TC570 \(product page\)](#)
5. [congatec conga-TCA7 \(product page\)](#)

Ethernet Driver



The congatec module drivers support one of the two Ethernet ports.

Intel i210 10/100/1000Mbps Ethernet:

6. [Intel Download Drivers & Software](#)

Serial Ports

7. [Sealevel Software: SeaCOM - Windows](#)

KVASER CAN CARD (Linux and Windows)

Mini PCI Express (2) HS-CAN or (2) CAN-FD:

8. [KVASER Downloads \(drivers\)](#)
9. [KVASER Associate Software](#)

Silex Technology Wi-Fi Card (Contact their support department for driver availability)

SX-PCEAN2 Radio Module:

10. [Silex Technology \(product page\)](#)

SeaCOM Windows Installation



To install Sealevel software, you must log in as an administrator or have administrator privileges.

1. Open Windows Explorer and navigate to the downloaded Sealevel software. For example: C:\Downloads\SS030705.exe
2. If you are using Windows Vista or newer operating systems, right click on the installer executable and choose 'Run as Administrator'. If you are using an operating system prior to Windows Vista, double click on the executable to launch the InstallShield wizard and initiate the driver installation.
3. Once opened Select 'Next' as demonstrated in the image below.

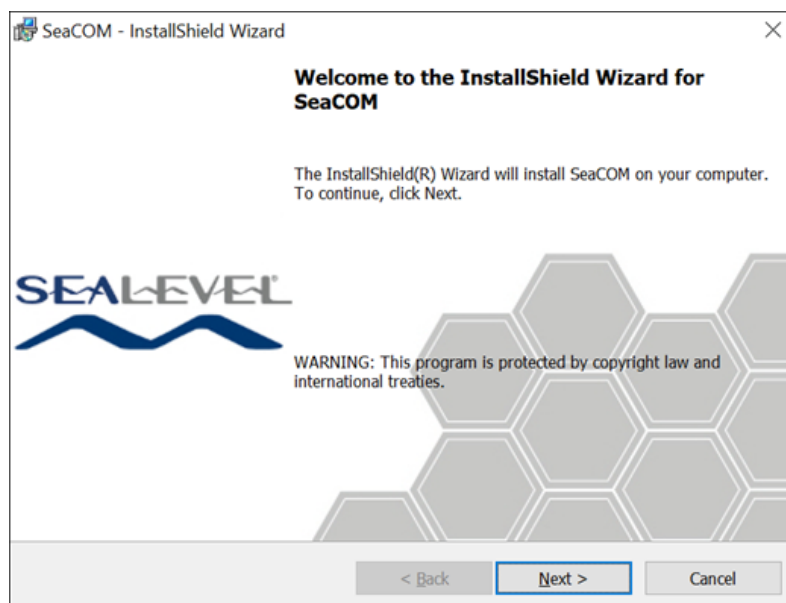

- When the 'License Agreement' window appears, accept the terms and click 'Next' to continue. If you do not accept the terms of the agreement, the wizard will stop.

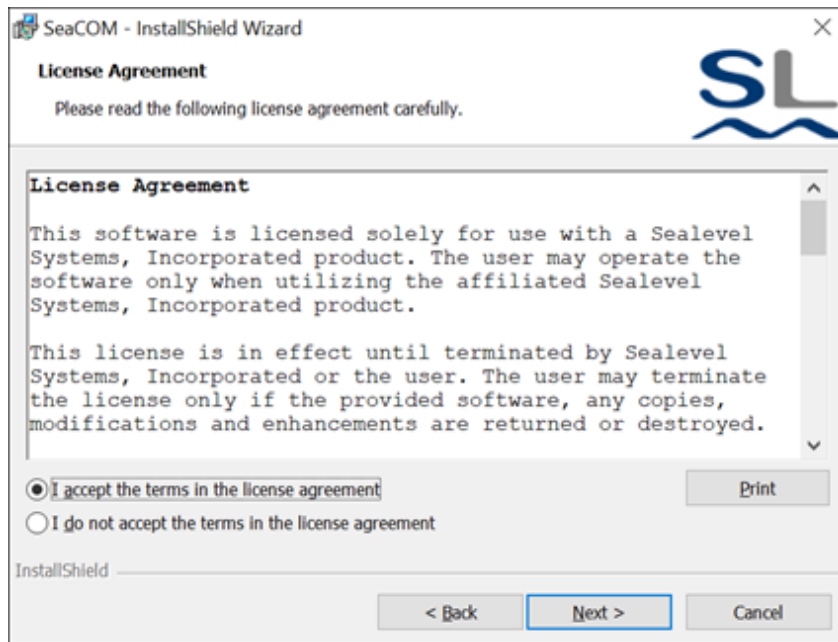

- When the 'Ready to Install the Program' window appears, click the 'Install' button to install the software onto the hard drive of your computer. Some versions of Windows will halt the installation and provide you with a dialog box which will ask you for permission for the installer to make changes to your computer. Click on the button to continue installation of your Sealevel software.

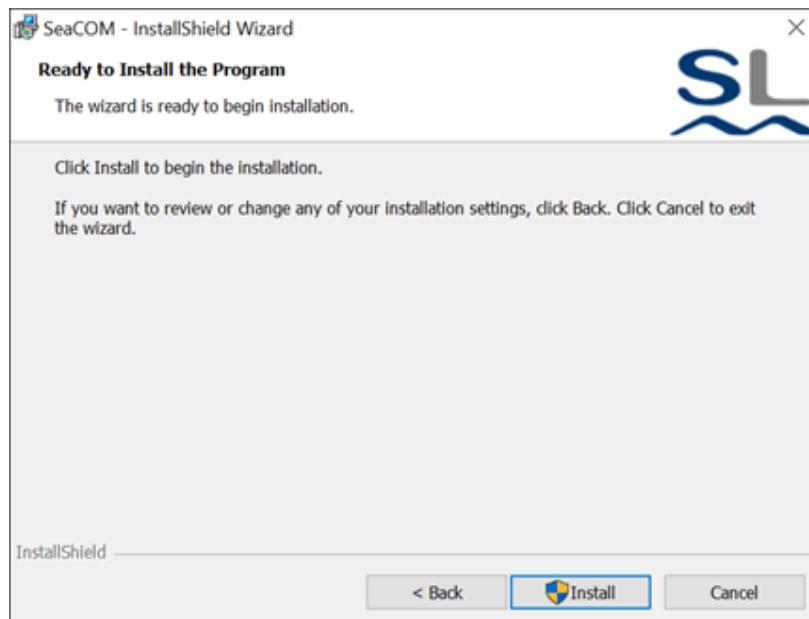

6. Click 'Finish' to complete the installation of SeaCOM onto your PC.

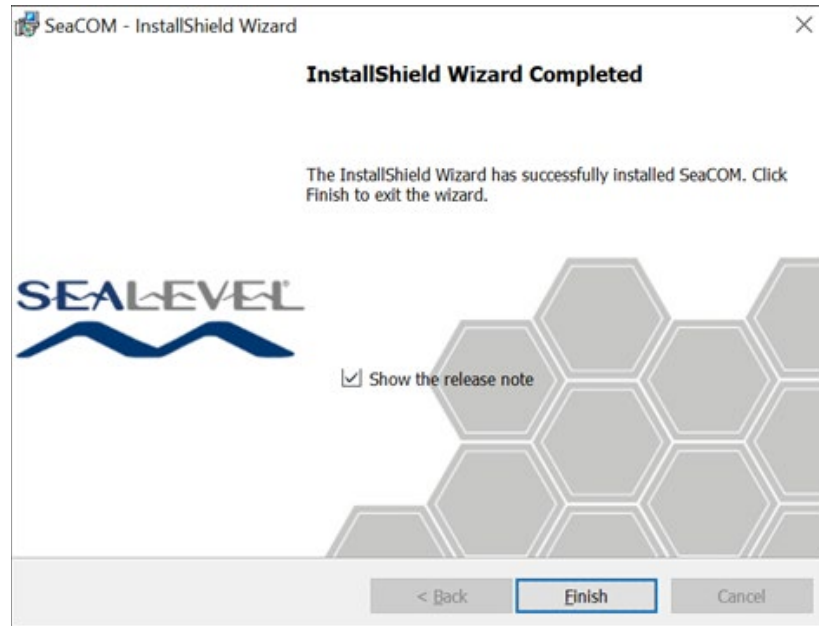

7. If prompted, reboot your computer for changes to take effect.

Upgrading to the current SeaCOM driver

1. Download the current driver using the Instructions from the Where to Get Software section above. Please take note of the destination directory it will save to.
2. Uninstall the currently loaded driver SeaCOM driver found in the Control Panel. In Windows 7 and later Oss, it will be found in the **Programs and Features** list.
3. Navigate to the Device Manager and remove the Sealevel adapter by right clicking on the line item and choosing **Uninstall**. Depending on your product, it can be found under either **Multiport Serial Adapters** or **Universal Serial Bus Controllers**.
4. In the Device Manager under **Action**, choose **Scan for Hardware Changes**. This will prompt the installation of the adapter and associate it with the newly installed SeaCOM driver.

Technical Specifications

Environmental Specifications

Specification	Operating	Storage
Temperature Range	TCA7 ATOM -40°C to 71°C (-40°F to 160° F) TC570 i5/i7 -40° C to 60° C (-40°F to 140° F)	-40° C to 85° C (-40° F to 185° F)
Humidity Range	10 to 90% R.H. Non-Condensing	10 to 90% R.H. Non-Condensing

Mechanical Dimensions

Length	6.64 inches	16.87 cm
Width	5.00 inches	12.70 cm
Height	1.90 inches	4.83 cm

Power Consumption

Absolute Operating Range:	18-36VDC
DC Current Rating (Dependent on COM Express Module, input voltage and load)	700mA – 2800 mA
Power Usage:	TCA7 Intel ATOM 6414RE Module : 15W nominal/ 25W max TCA7 Intel ATOM 6425RE Module : 15W nominal/ 25W max TC570 Intel i5 1145GRE Module : 25W nominal/ 50W max TC570 Intel i7 1185GRE Module : 25W nominal / 50W max

Manufacturing

All Sealevel Systems Printed Circuit boards are built to UL 94V0 rating and are 100% electrically tested. These printed circuit boards are solder mask over bare copper or solder mask over tin nickel.

MTBF (Telcordia SR-332, Issue 4 calculation prediction method)

Mean Time Between Failure	550,100 hours	At 25° C ambient (ground benign)
----------------------------------	---------------	----------------------------------

Operating Temperature Range

Part Number	COM Express Module	Operating Temperature Range	Comment
R17316xx-DPDV	congatec TC570	-40°C to +60 °C	Requires Industrial Temperature SSD3
R15416xx-DPDV	congatec TC570	-40°C to +60 °C	Requires Industrial Temperature SSD3
R14316xx-DPDV	congatec TCA7	-40°C to +71 °C	Requires Industrial Temperature SSD3
R14216xx-DPDV	congatec TCA7	-40°C to +71 °C	Requires Industrial Temperature SSD3

System Operation

Power and Reset and buttons

A full system Hardware Reset is provided by a recessed tactile switch. The Processor and peripherals will be issued a reset command when the Reset button is pressed and held for 1 second. Use a blunt non-conductive instrument to depress the reset button.

Just like with the Reset button, the Power button needs to be pressed and held for 3 seconds to turn the device on or off.

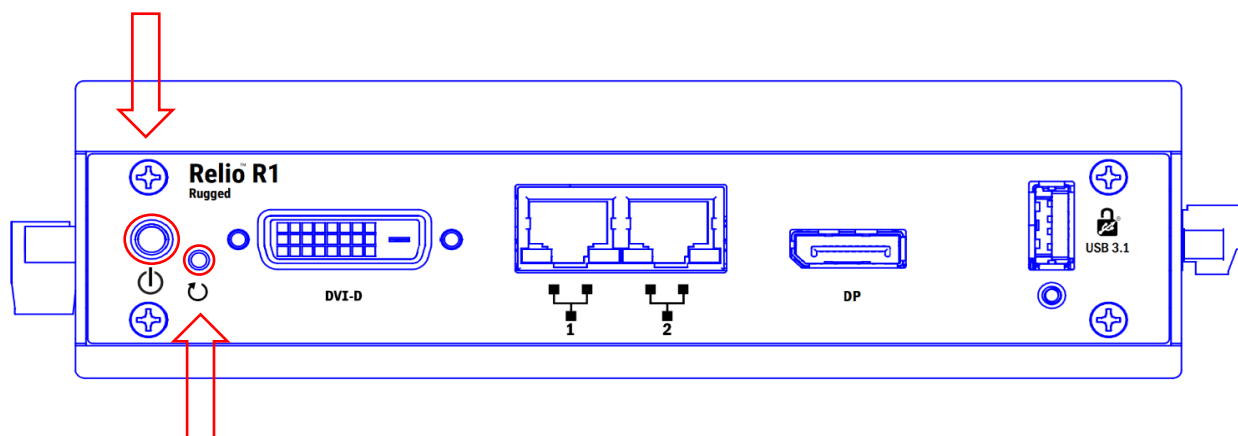

Power Button (on the Left) and Reset Button (on the Right)

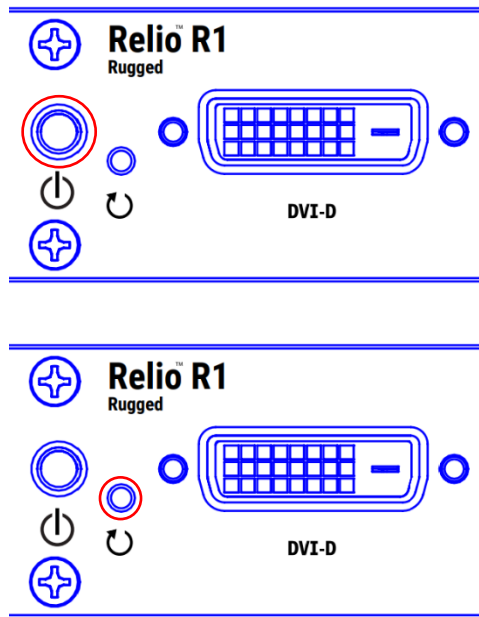

High Performance Serial Communication Ports

Features of the serial ports include:

- Two independent software selectable and configurable serial ports (RS-232/485)
- Software selectable RS-485 termination and biasing
- Max Data Rate of 20Mbps in RS-485 modes and 1Mbps in RS-232 Mode.
- Automatic RS-485 enable/disable in hardware for Windows applications.
- Windows driver selectable 250K slew rate limiting to minimize electromagnetic interference.
- Sealevel's SeaCOM enhanced serial driver.

The R1 Rugged has two high speed serial communication ports supporting data rates up to 20Mbps in RS-485 modes and 1Mbps in RS-232 Mode. These ports are software selectable RS-232/RS-485 electrical interfaces. They can also be configured in software (SeaCOM). The ports typically enumerate as COM 3 and 4 when the software driver is installed however, these are logical designations, so they can be changed to other designations.

In general, the RS-485 interface port is used for communication with equipment up to 4000 ft. away from the computer or in noisy environments. The RS-485 2-wire mode is optimized for "Multi-Drop" or "Party-line" operations selecting data from multiple peripherals (as many as 32 unit load devices can be connected on an RS-485 bus).

In RS-485 mode, our special auto-enable feature allows the RS-485 ports to be viewed by the operating system as a COM: port. This allows the software application to utilize the serial port for RS-485 communication without the need to control the direction of data between the master and slave device. Our on-board hardware automatically handles the RS-485 driver enable.

Clock Modes and Baud Rates

The R1 Rugged derives a 125MHz clock from the PCI express link for the Baud Rate Generator (BRG) which is divided by a clock prescaler (1 or 4) and a 16-bit clock divisor to obtain a sampling clock of 16X, 8X, or 4X the serial data rate. The BRG offers a wide range of possible baud rates. Under Windows and Linux, the best choice of divisor is made automatically by the driver. The bit rate error is within the +/- 2% recommended tolerance for proper serial communication.

Serial Interface Selection

Access to and configuration of the serial ports is provided by Sealevel's SeaCOM driver and port management software.



Before configuring, the COM ports must be closed by all applications using the ports.

The Port Manager application in the SeaCOM suite of communication utilities is used to set the Interface Mode and Options for the Serial Ports of the computer. For the COM Port(s) to be configured, they must be closed in other applications that control them before the Port Manager utility can configure them. Likewise, other applications cannot open the COM Ports while they are open in the SeaCOM Port Manager.

The Port Manager utility will open with the COM Ports listed on the left-side of the window and COM1 configuration in the right-side window. COM 1 is an internal serial port that is not accessible externally to the computer. The external Serial Ports available on the R1 Rugged Industrial Computer are COM3 and COM4.

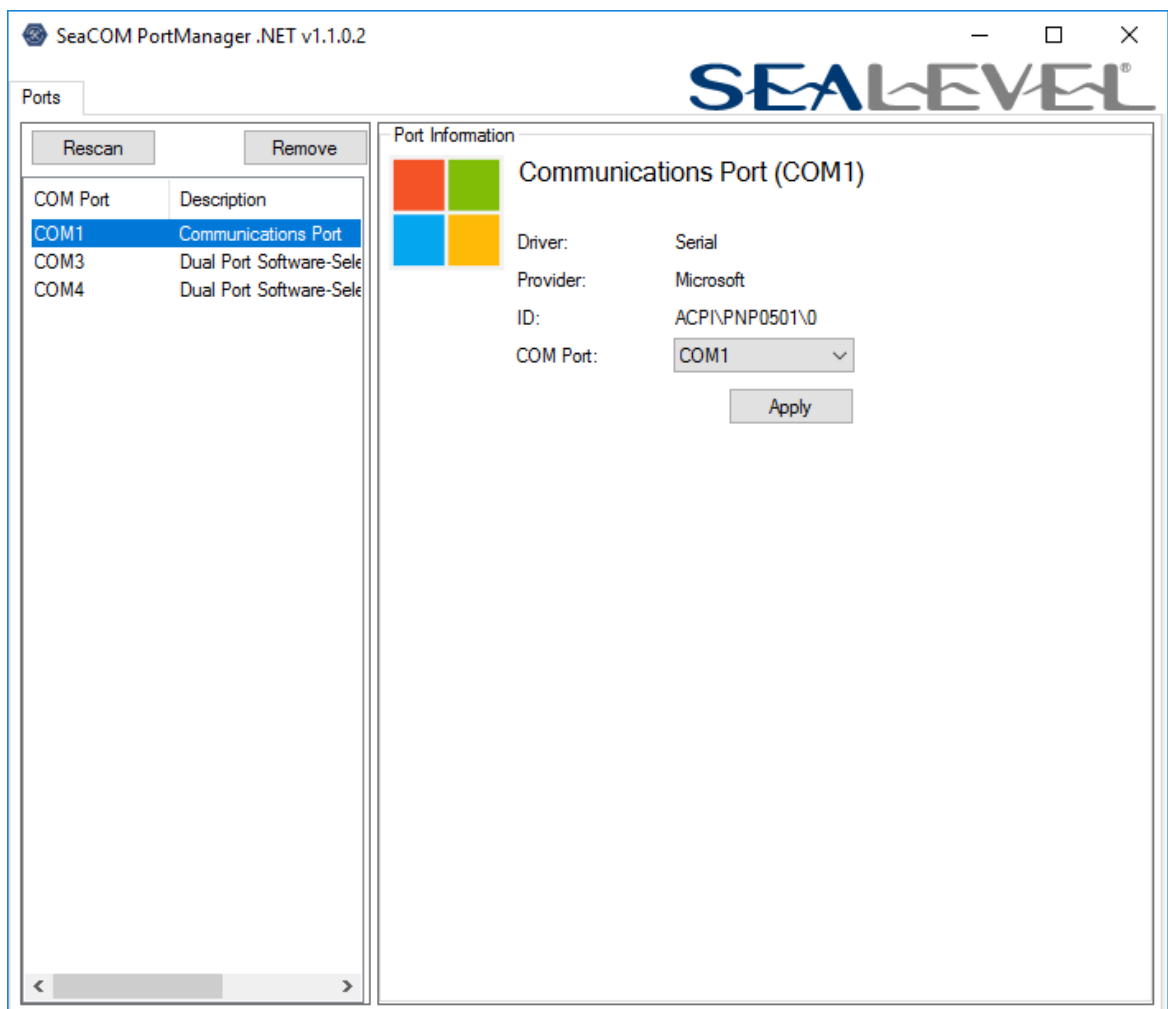

*Initial
Start
Screen
for
Port*

Manager

COM Port Configuration

The right-side window of the Port Manager is the configuration box. The COM Port to be configured is selected by clicking on the desired COM Port option in the left side window. This will display the current COM Port Electrical Interface settings. The first time the Port Manager is used the configuration will be RS-232, all other boxes unchecked, and RS-485 Auto-Enable set to 0. The settings are stored when applied and displayed with subsequent uses of the Port Manager.

The changed settings will be activated when the Apply button at the bottom of the configuration box is clicked. This also closes the port, allowing other applications to open it.

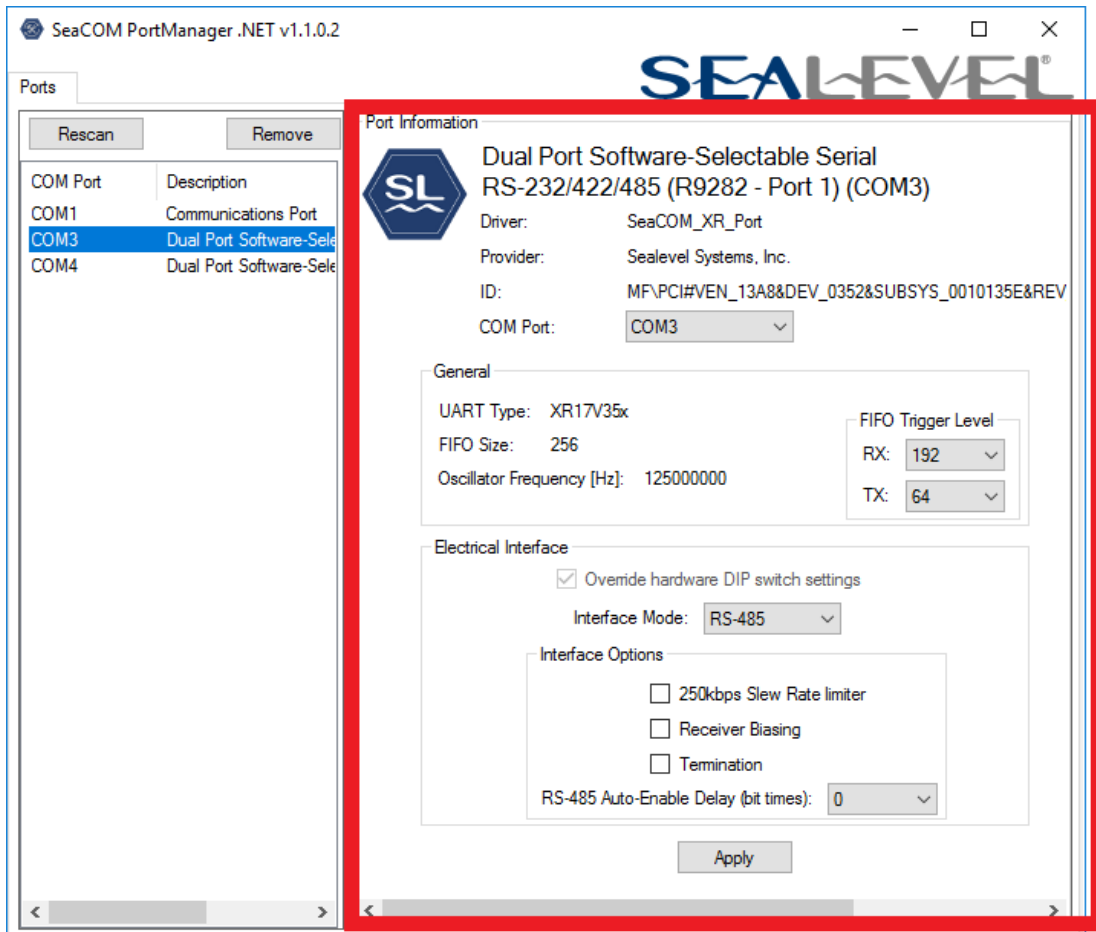

COM3 Configuration example

In the Electrical Interface section, the Interface Mode option is used to set the protocol for COM Port selected. The choices are:

- Tri-State No external signal communication
- RS-232 Single ended signaling, point-to-point serial communication mode
- RS-485 Differential, twisted pair, multidrop serial communication mode

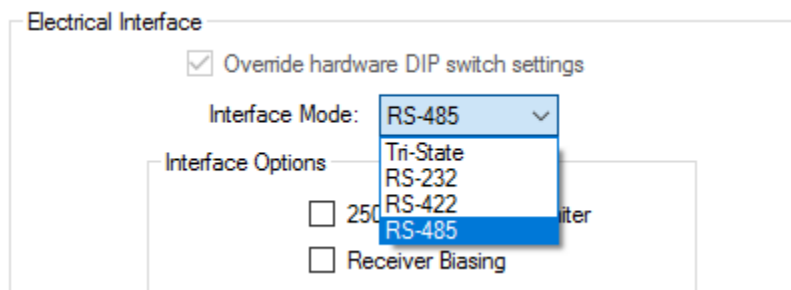

Electrical Interface section

RS-485 Enable Modes

RS-485 is ideal for multi-drop or network environments like that used by Seal/O modules. RS-485 requires a tristate line driver IC that will allow the electrical presence of the driver to be removed from the line when not transmitting data. The line driver is in a tristate or high impedance condition when this occurs.

Only one driver may be active at a time on a bus and the other driver(s) must be tri-stated. Under Windows, configuring the port for RS-485 also configures the port to automatically control the transmit enable of the transceiver, its RTS output, at the start of each transmission. This causes the RS-485 data transmission driver to leave tristate, allowing it to transmit data. In RS-485 mode under Windows; the port is also set to automatically de-assert its output on the bus at the end of each transmission. This returns the RS-485 data transmission driver to tristate, so that other drivers can transmit on the line.

Slew Rate Limiting

Slew Rate Limiting (250kbps) is an additional configuration setting available only via software selection. It helps minimize the generation of electromagnetic interference. It slows the rise and fall times of the data transitions where higher baud rates are not required. This can be used for any baud rates 250kbps or lower.

Receiver Biasing

The receiver biasing option connects a 560 Ohm resistor to each pin of the input of the receivers to prevent an indeterminate state from causing noise to be interpreted as data being received. The RX+ pin is pulled up to 3.3V and the RX- pin is pulled down to GND. The receiver biasing is typically only connected to Master node of a RS-485 bus. It is recommended to only use one biasing set on a bus.

Line Termination Selection via Hardware

Typically, the device at each end of the RS-485 bus must have line-terminating resistors. When the end device is the R1 Rugged Industrial Computer, you will need to connect a built in 120-ohm resistor between each RS-485 input pair in addition to a 560-ohm pull-up/pull-down combination that biases the RX+ and RX- receiver inputs. Termination is required when the propagation delay of the data is equal to, or greater than, one bit (pulse duration) to suppress data reflection. Termination is only required on the extreme ends of the data bus. Typically, the Master device on the RS-485 bus is physically located in the middle of the bus to maximize signal strength and reliability; therefore, it does not have a termination resistor. Connecting the bias and termination resistors is accomplished in the Port Manger application.

RS-485 Auto-Enable Delay

RS-485 Auto-Enable Delay is an additional configuration setting available only via software selection. It provides a 0 to 15 bit-time delay that is inserted after the end of the last stop-bit of the last transmitted character. This delay controls when to automatically disable the RS-485 transmitter and place it in the Tri-State (high impedance) condition. This delay may be useful in long-cable networks.



The screenshot shows a configuration window titled "Interface Options". It contains three unchecked checkboxes: "250kbps Slew Rate limiter", "Receiver Biasing", and "Termination". Below these is a dropdown menu for "RS-485 Auto-Enable Delay (bit times)" which is currently set to "0".

Interface Options section

Appendix A – Troubleshooting Serial Communication Issues

Ensure that the Sealevel Systems SeaCOM software has been installed on the machine, so that the necessary files are in place to complete the installation. To confirm installation, click on the Windows 'Start' button and then select 'All Programs.' You should see the 'SeaCOM' program folder listed.

Check to make sure that USB support is enabled and functioning properly in the operating system. Right click on the Start Menu, then click on the Device Manager and expand the Ports (COM & LPT) section. You should see 4 COM ports. Two labeled for RS232 and two labeled for RS485

Always use the Sealevel Systems diagnostic software when troubleshooting a problem. This will eliminate any software issues from the equation.

Troubleshooting/Verification for Asynchronous Serial Products

The R1 Rugged has two 2-wire RS-485 serial ports, meaning the transmitter and receiver to the same data channel. For this reason, an external loopback adapter will not work with 2-wire RS-485.

To successfully perform a loop back test with 2-wire RS-485, the easiest method is to connect the two adjacent serial ports together and use the BERT function in the [Sealevel WinSSD utility](#).

See the steps below on the RS-232 ports and RS-485 ports on the R1 Rugged:

1. RS-232 requires pins 2 (Receive) & 3 (Transmit) to be jumpered as shown in this graphic:



If you do not have a loopback plug or jumper wires handy, you can use a metal device, such as a knife, screwdriver, key, or paperclip, to short pins two and three.

2. The RS-485 ports are half duplex. To test these ports, we will need to jump Port 1 and Port 2 together, as shown in the graphic below.

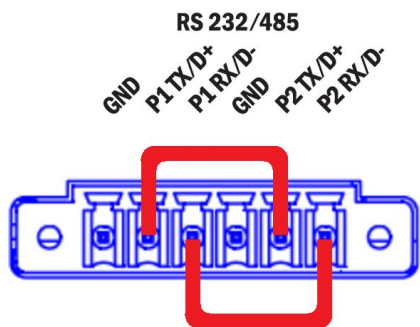

6 Position Terminal Block

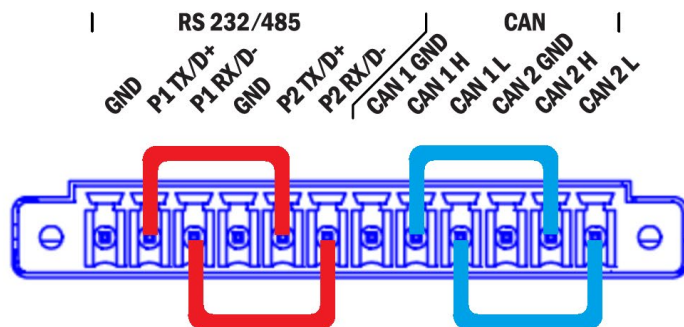

12 Position Terminal Block

To test communications, launch the WinSSD utility in the SeaCOM folder in the 'Start' menu.

3. On the 'Port Information' tab, select the associated COM port and click the 'Open' button.
 - (RS485 only): Launch a second WinSSD window and select the COM port of the other RS485 port.
4. This will first open the COM port. From this tab the port can also be closed (See image below). Click the 'Settings' button to open the COM Port Properties dialog box. This will allow the Port Settings to be altered.

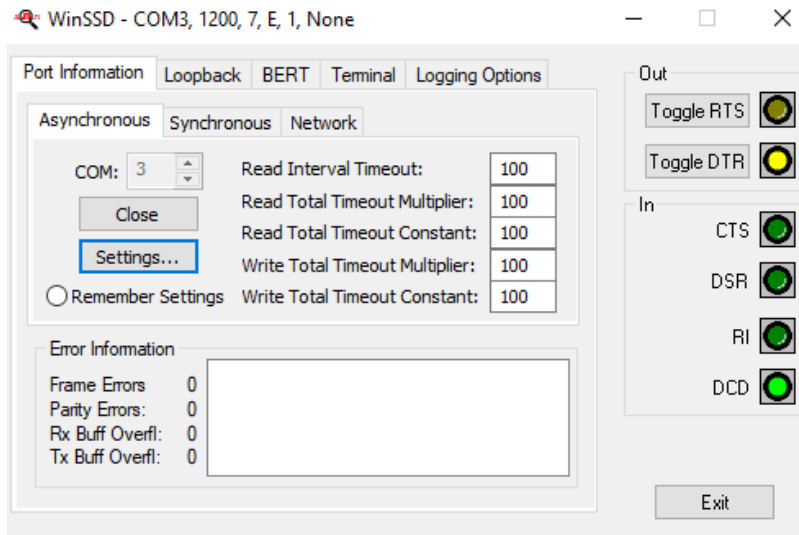

5. Change your parameters to 9600 bits per second, 8 data bits, no parity, 1 stop bit, and no flow control, as pictured below.

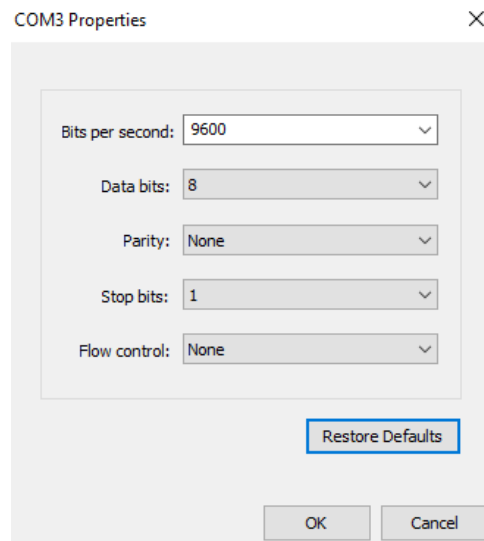

6. Click 'Apply' and 'OK.'
7. In the main WinSSD window, click on the 'BERT' tab (Bit Error Rate test).

8. (RS232) Click on the 'Start' button.

(RS485) Only click 'Start' on one instance of WinSSD. Since the RS485 ports are half duplex we cannot run the BERT test simultaneously on both ports.

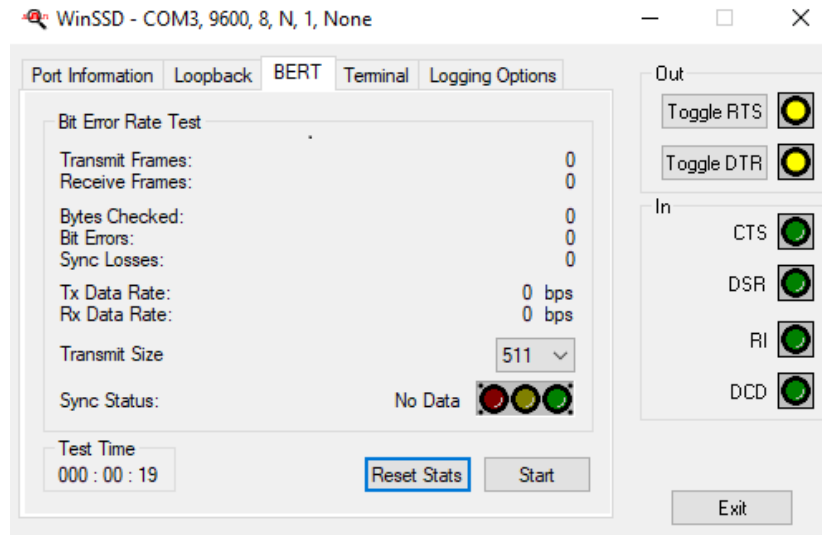

9. (RS232) If the COM port is properly working, the Sync Status green light will glow, and the Transmit Frames and Receive Frames will increase. The Tx and Rx Data Rates will show the calculated data rate.

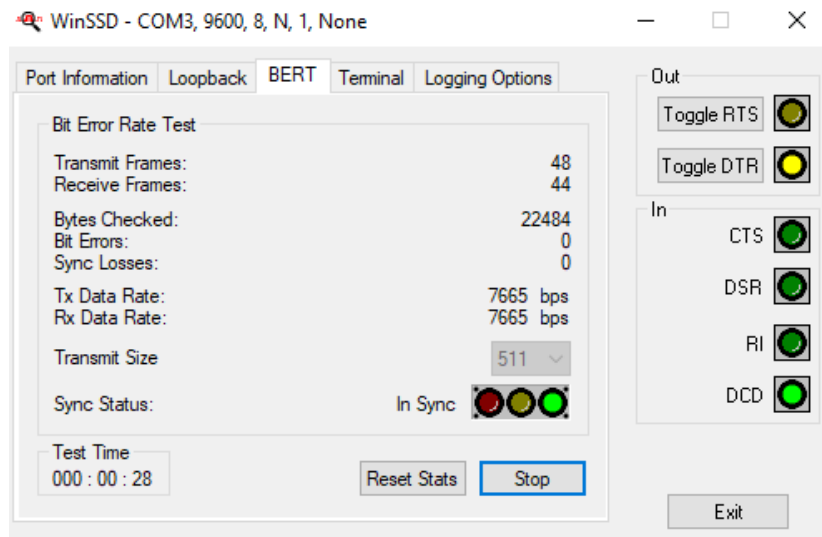

Passing RS232 loopback test

10. (RS 485) If the COM port is properly working, the Sync Status green light will glow on the receive port. Transmit Frames will increase on the port running the BERT test, Receive Frames will increase on the receive port. The Tx and Rx Data Rates will show the calculated data rate.

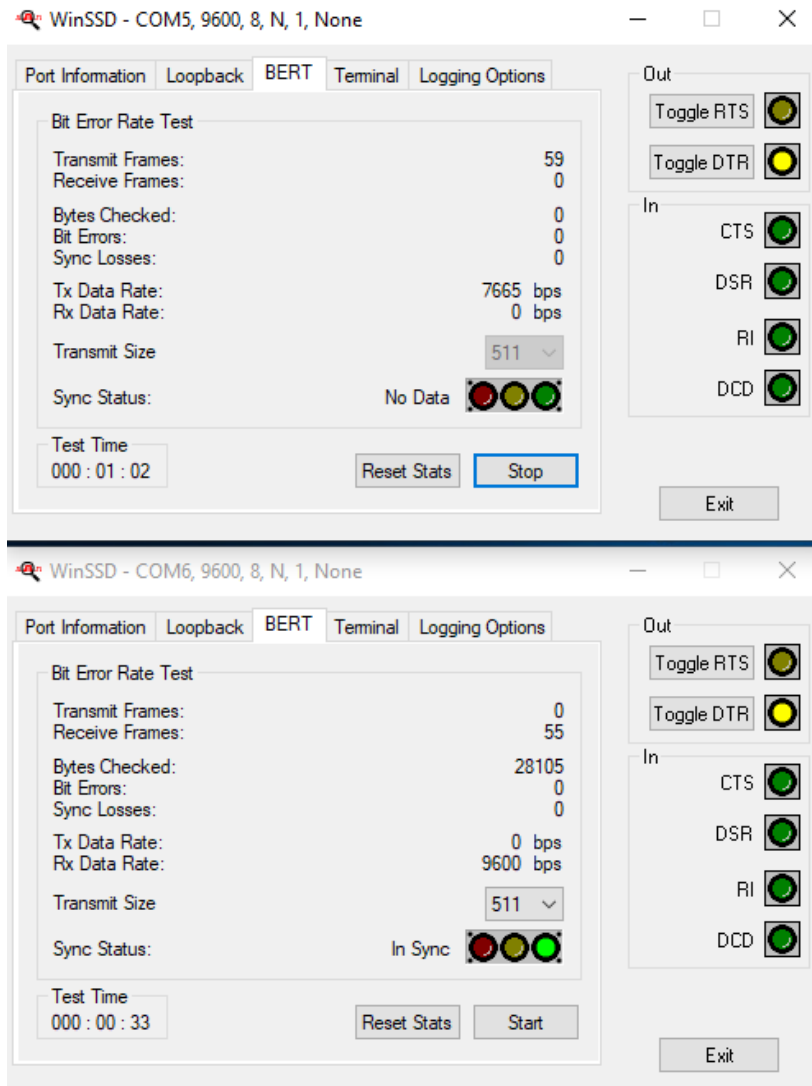

Passing RS485 loopback test - WinSSD in top image is transmitting port

11. (RS485 only) Click on the 'Stop' button. Repeat steps 11 and 12 on the other port.

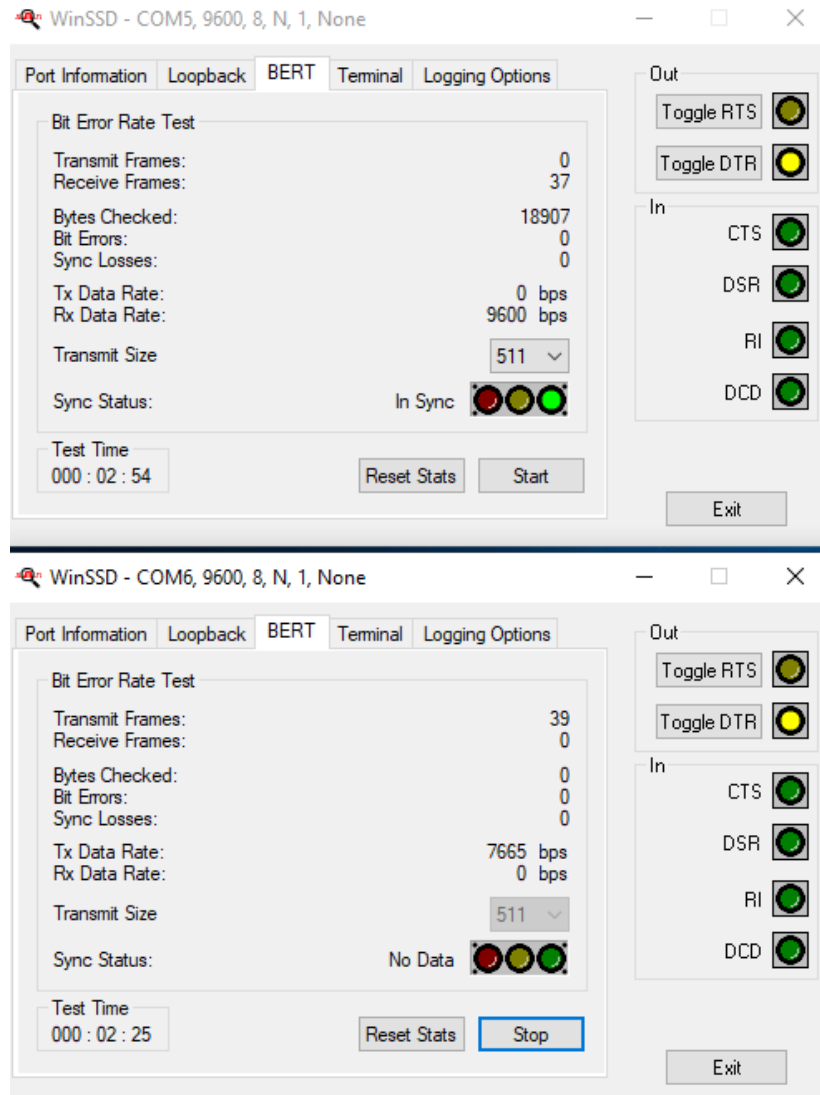

Passing RS485 loopback test - WinSSD in bottom image is transmitting port.

12. This verifies that the adapter is working properly. You can continue testing this port with different configurations or proceed with testing other ports, if necessary.

Appendix B – How To Get Assistance

Please refer to: [Appendix A](#) – Troubleshooting Guide prior to calling Technical Support.

Begin by reading the Trouble Shooting Guide in Appendix A. If assistance is still needed, please see below.

When calling for technical assistance, please have your user manual and current adapter settings. If possible, please have the adapter installed in a computer ready to run diagnostics.

Sealevel Systems provides an FAQ section on its web site. Please refer to this to answer many common questions. This section can be found at <http://www.sealevel.com/faq.asp>.

Sealevel Systems maintains a web page on the Internet. Our home page address is www.sealevel.com. The latest software updates, and newest manuals are available via our web site.

Technical support is available Monday to Friday from 8:00 AM to 5:00 PM Eastern Time. Technical support can be reached at (864) 843-4343.

RETURN AUTHORIZATION MUST BE OBTAINED FROM SEALEVEL SYSTEMS BEFORE RETURNED MERCHANDISE WILL BE ACCEPTED. AUTHORIZATION CAN BE OBTAINED BY CALLING SEALEVEL SYSTEMS AND REQUESTING A RETURN MERCHANDISE AUTHORIZATION (RMA) NUMBER.

Appendix C – Compliance Notices

Federal Communications Commission (FCC) Statement



This equipment has been tested and found to comply with the limits for a Class A digital device, pursuant to part 15 of the FCC Rules. Operation is subject to the following two conditions: (1) This device may not cause harmful interference, and (2) this device must accept any interference received, including interference that may cause undesired operation.

ISED Canada

- **CAN ICES-003(A) / NMB-003(A)**

EMC Directive Statement



This equipment has been evaluated or tested and found in compliance with the requirements of the following directives issued by the European Commission:

- EMC Directive **2014/30/EU**
- RoHS Directive **2011/65/EU + (EU) 2015/863**



CE marking is recognized in the UK as an acceptable method of demonstrating compliance for certain categories of products, including one described in this manual.



This is a Class A Product. In a domestic environment, this product may cause radio interference in which case the user may be required to take adequate measures to prevent or correct the interference.



Always use cabling provided with this product if possible. If no cable is provided or if an alternate cable is required, use high quality shielded cabling to maintain compliance with FCC/EMC directives.

Appendix D - Handling Instructions

Electrostatic Discharges (ESD)

A sudden electrostatic discharge can destroy sensitive components. Proper packaging and grounding rules must therefore be observed. Always take the following precautions:

- Transport boards and cards in electrostatically secure containers or bags.
- Keep electrostatically sensitive components in their containers, until they arrive at an electrostatically protected workplace.
- Only touch electrostatically sensitive components when you are properly grounded.
- Store electrostatically sensitive components in protective packaging or on anti-static mats.

Grounding Methods

The following measures help to avoid electrostatic damages to the device:

- Cover workstations with approved antistatic material. Always wear a wrist strap connected to a properly grounded workplace.
- Use antistatic mats, heel straps, and/or air ionizers for more protection.
- Always handle electrostatically sensitive components by their edge or by their casing.
- Avoid contact with pins, leads, or circuitry.
- Turn off power and input signals before inserting and removing connectors or connecting test equipment.
- Keep work area free of non-conductive materials such as ordinary plastic assembly aids and Styrofoam.
- Use field service tools such as cutters, screwdrivers, and vacuum cleaners that are conductive.

Appendix E – Electrical Interface

RS-232

Quite possibly the most widely used communication standard is RS-232. This implementation has been defined and revised several times. It is often referred to as RS-232 or EIA/TIA-232. The IBM PC computer defined the RS-232 port on a 9-pin D-sub connector, and subsequently, the EIA/TIA approved this implementation as the EIA/TIA-574 standard. This standard is defined as the 9-Position Non-Synchronous Interface between Data Terminal Equipment and Data Circuit-Terminating Equipment Employing Serial Binary Data Interchange. Both implementations are in widespread use and will be referred to as RS-232 in this document.

RS-232 is capable of operating at data rates up to 20K bps at distances less than 50 ft. The absolute maximum data rate may vary due to line conditions and cable lengths. RS-232 is a single-ended or unbalanced interface, meaning that a single electrical signal is compared to a common signal (ground) to determine binary logic states. The RS-232 and the EIA/TIA-574 specification define two types of interface circuits: Data Terminal Equipment (DTE) and Data Circuit-Terminating Equipment (DCE).

RS-485

RS-485 is backward compatible with RS-422; however, it is optimized for partyline or multi-drop applications. The output of the RS-485 driver is capable of being Active (enabled) or Tri-State (disabled). This capability allows multiple ports to be connected in a multi-drop bus and selectively polled. RS-485 allows cable lengths up to 4000 feet and data rates up to 10 Megabits per second. The signal levels for RS-485 are the same as those defined by RS-422.

RS-485 has electrical characteristics that allow for 32 drivers and 32 receivers to be connected to one line. This interface is ideal for multi-drop or network environments. RS-485 tri-state driver (not dual-state) will allow the electrical presence of the driver to be removed from the line. Only one driver may be active at a time and the other driver(s) must be tri-stated. RS-485 can be cabled in two ways: two wire and four wire mode. Two wire mode does not allow for full duplex communication and requires that data be transferred in only one direction at a time. For half-duplex operation, the two transmit pins should be connected to the two receive pins (Tx+ to Rx+ and Tx- to Rx-). Four wire mode allows full duplex data transfers. RS-485 does not define a connector pin-out or a set of modem control signals. RS-485 does not define a physical connector.

Appendix F – Asynchronous Communications

Serial data communications imply that individual bits of a character are transmitted consecutively to a receiver that assembles the bits back into a character. Data rate, error checking, handshaking, and character framing (start/stop bits) are pre-defined. They must correspond at both the transmitting and receiving ends.

Asynchronous communications are the standard means of serial data communication for PC compatible and PS/2 computers. The original PC was equipped with a communication (COM) port that was designed around an 8250 Universal Asynchronous Receiver Transmitter (UART). This device allows asynchronous serial data to be transferred through a simple and straightforward programming interface. A starting bit followed by a pre-defined number of data bits (5, 6, 7, or 8) defines character boundaries for asynchronous communications. The end of the character is defined by the transmission of a pre-defined number of stop bits (usually 1, 1.5, or 2). An extra bit used for error detection is often appended before the stop bits. The diagram below demonstrates asynchronous communication bits.

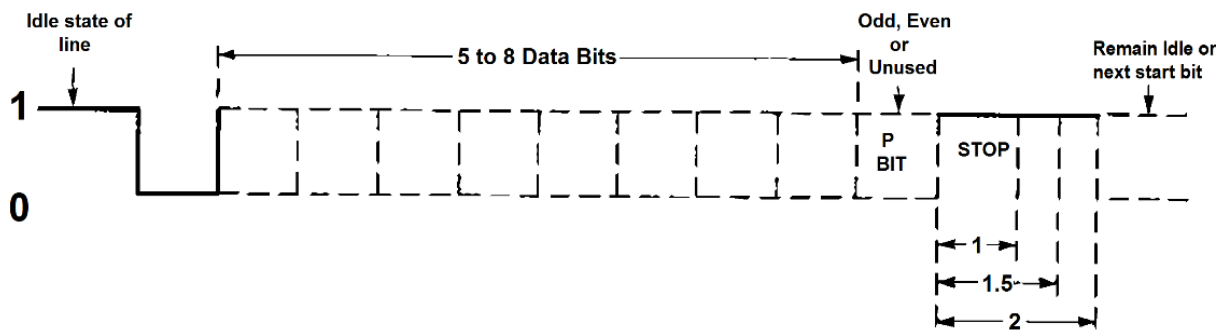

The parity bit is a simple method of determining if a data bit has been lost or corrupted during transmission. There are several methods for implementing a parity check to guard against data corruption. Common methods are called (E)ven Parity or (O)dd Parity. Sometimes parity is not used to detect errors on the data stream. This is referred to as (N)o parity. Because each bit in asynchronous communications is sent consecutively, it is easy to generalize asynchronous communications by stating that each character is wrapped (framed) by pre-defined bits to mark the beginning and end of the serial transmission of the character. The data rate and communication parameters for asynchronous communications have to be the same at both the transmitting and receiving ends. The communication parameters are baud rate, parity, number of data bits per character, and stop bits (i.e., 9600,N,8,1).

Warranty

Sealevel's commitment to providing the best I/O solutions is reflected in the Lifetime Warranty that is standard on all Sealevel manufactured I/O products. We are able to offer this warranty due to our control of manufacturing quality and the historically high reliability of our products in the field. Sealevel products are designed and manufactured at its Liberty, South Carolina facility, allowing direct control over product development, production, burn-in and testing. Sealevel achieved ISO-9001:2015 certification in 2018.

Warranty Policy

Sealevel Systems, Inc. (hereafter "Sealevel") warrants that the Product shall conform to and perform in accordance with published technical specifications and shall be free of defects in materials and workmanship for the warranty period. In the event of failure, Sealevel will repair or replace the product at Sealevel's sole discretion. Failures resulting from misapplication or misuse of the Product, failure to adhere to any specifications or instructions, or failure resulting from neglect, abuse, accidents, or acts of nature are not covered under this warranty.

Warranty service may be obtained by delivering the Product to Sealevel and providing proof of purchase. Customer agrees to ensure the Product or assume the risk of loss or damage in transit, to prepay shipping charges to Sealevel, and to use the original shipping container or equivalent. Warranty is valid only for original purchaser and is not transferable.

This warranty applies to Sealevel manufactured Product. Product purchased through Sealevel but manufactured by a third party will retain the original manufacturer's warranty.

Non-Warranty Repair/Retest

Products returned due to damage or misuse and Products retested with no problem found are subject to repair/retest charges. A purchase order or credit card number and authorization must be provided in order to obtain an RMA (Return Merchandise Authorization) number prior to returning Product.

How to obtain an RMA (Return Merchandise Authorization)

If you need to return a product for warranty or non-warranty repair, you must first obtain an RMA number. Please contact Sealevel Systems, Inc. Technical Support for assistance:

Available	Monday – Friday, 8:00AM to 5:00PM EST
Phone	864-843-4343
Email	support@sealevel.com

Trademarks

Sealevel Systems, Incorporated acknowledges that all trademarks referenced in this manual are the service mark, trademark, or registered trademark of the respective company.