

# ISO-16.PCI

User Manual | 8006e

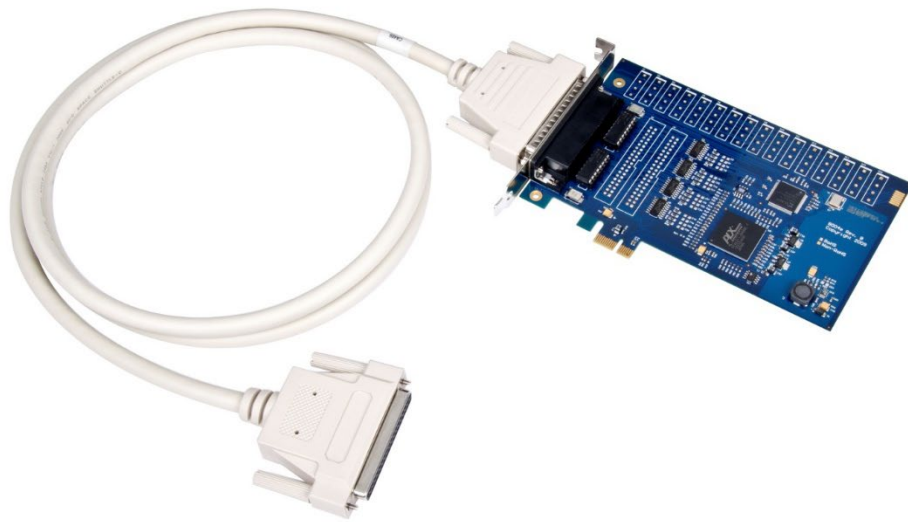

**SEALEVEL®**

# Contents

CONTENTS.....	2
BEFORE YOU GET STARTED .....	4
WHAT'S INCLUDED .....	4
ADVISORY CONVENTIONS.....	4
PRODUCT DESCRIPTION.....	5
FEATURES.....	5
OPTIONAL ITEMS.....	6
ELECTRICAL SPECIFICATIONS.....	7
FEATURES.....	7
INPUT PORTS.....	7
TECHNICAL SPECIFICATIONS.....	8
ENVIRONMENTAL SPECIFICATIONS.....	8
MANUFACTURING.....	8
PHYSICAL DIMENSIONS.....	8
HARDWARE INSTALLATION .....	9
VERIFYING INSTALLATION .....	10
PROGRAMMING THE ISO-32.PCIE .....	11
PROGRAMMING FOR WINDOWS.....	11
PROGRAMMING FOR LINUX.....	11
DIGITAL I/O INTERFACE.....	11
INPUT PORTS.....	12
INPUT PORTS PIN ASSIGNMENTS (DB-37 FEMALE).....	14
DB-78 FEMALE PIN ASSIGNMENTS (CARD EDGE CONNECTOR) .....	15
DIRECT HARDWARE CONTROL .....	16
READING THE INPUTS.....	16
REGISTER DESCRIPTION .....	16
EXAMPLE CIRCUITS .....	17
INPUT CIRCUIT .....	17
SOFTWARE INSTALLATION .....	18
OPERATING SYSTEM INSTALLATION .....	18
OTHER OPERATING SYSTEMS.....	18
LINUX INSTALLATION .....	19
APPENDIX A – HANDLING INSTRUCTIONS .....	20
ESD WARNINGS.....	20
APPENDIX B – TROUBLESHOOTING.....	21

APPENDIX C – HOW TO GET ASSISTANCE..... 24

APPENDIX D - DRAWING ..... 25

APPENDIX E – COMPLIANCE NOTICES..... 26

WARRANTY ..... 27

    WARRANTY POLICY ..... 27

    NON-WARRANTY REPAIR/RETEST..... 27

    HOW TO OBTAIN AN RMA (RETURN MERCHANDISE AUTHORIZATION) ..... 27

    TRADEMARKS ..... 27

# Before You Get Started

## What's Included

The 8006e is shipped with the following items. If any of these items are missing or damaged, please contact Sealevel for replacement.

- **8006e - ISO-16.PCIE Digital I/O Adapter**
  - **8006e – Board with 3-13V inputs**
  - **8006He – Board with 10-30V inputs**
- **DB78 Male to DB37 Female cable (Item# CA489)**

## Advisory Conventions



### Warning

The highest level of importance used to stress a condition where damage could result to the product, or the user could suffer serious injury.



### Important

The middle level of importance used to highlight information that might not seem obvious or a situation that could cause the product to fail.



### Note

The lowest level of importance used to provide background information, additional tips, or other non-critical facts that will not affect the use of the product.

# Product Description

The ISO-16.PCIE digital I/O interface provides 16 optically isolated inputs. The inputs protect the PC and other sensitive equipment from spikes and ground loop current that can be generated in industrial environments.

The Seal/O Classic software drivers and utilities make installation and operation easy using Windows 7, Vista, and XP operating systems. The Seal/O API (Application Programmer Interface) provides a variety of useful high-level function calls implemented as a Windows dynamic link library (DLL) and as a Linux kernel module and library. Seal/O also includes sample code and utilities to simplify software development.

The inputs on the 8006e are rated for 3-13V. The inputs on the 8006He are rated for 10-30V.

## Features

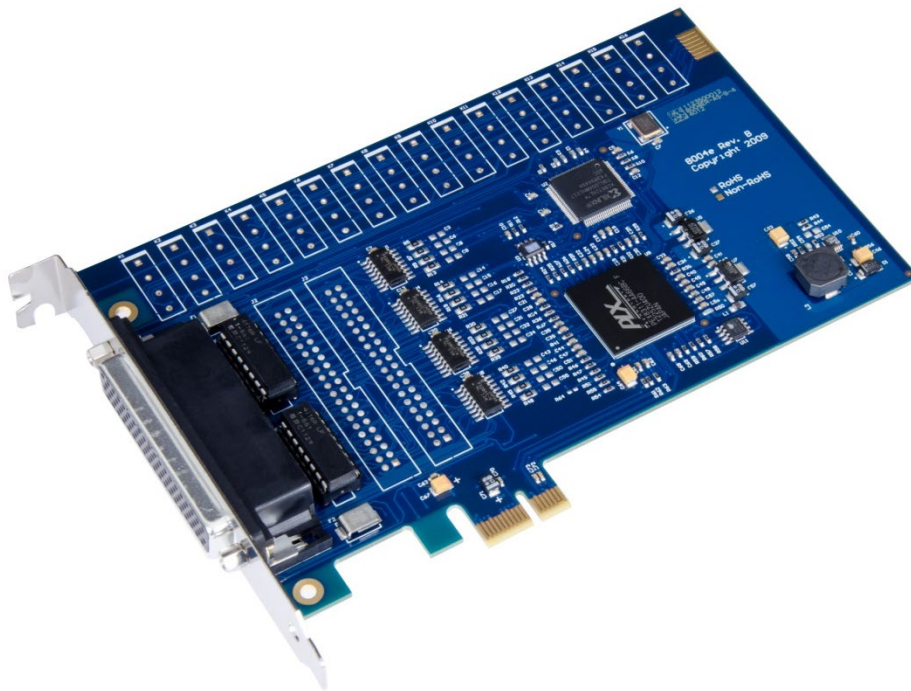

- PCI Express X1 compliant
- 16 optically isolated inputs
- Socketed dip resistor allows user configurable input range up to +30V
- Power (+5V and +12V) and ground provided on DB78 board connector
- Includes 72" cable with DB78 Male connector to DB37 Female connectors (Item# CA489)
- Seal/O Classic software supports Windows 7, Vista, and XP operating systems
- Software support for Linux available



## Optional Items

Depending upon your application, you are likely to find one or more of the following items useful with the 8006e. All items can be purchased from our website ([www.sealevel.com](http://www.sealevel.com)) by calling our sales team at (864) 843-4343.

## Cables

<b>DB37 Male to DB37 Female Extension Cable (Item# CA112)</b>	
This cable provides a 6' extension to the CA165. It has one DB37 Male connector and one DB37 Female connector.	
<b>DB78 Male to DB78 Female Extension Cable (Item# CA233)</b>	
This cable provides a 6' extension to the DB78 board connector on the 8006e. It has one DB78 Male connector and one DB78 Female connector.	
<b>DB78M to DB37 Female and DB37 Male, for 3093 (Item# CA378)</b>	
The CA378 is designed specifically for customers using the 3093 ISA digital I/O board that need to upgrade to the 8006e PCIe board while preserving existing infrastructure wiring. The CA378 connects to the 8006e and provides an identical pin out to the 3093.	

## Terminal Blocks

<b>DB37 Terminal Block (Item# TB02)</b>	
Break out serial and digital connectors to screw terminals for easy field connection. The TB02 terminal block is designed with both DB37 male and female connectors for interfacing the inputs or outputs.	

# Electrical Specifications

## Features

- 2 eight-bit input ports
- DB-37 Female connector for optically isolated inputs
- Multiple adapters can reside in same computer

## Input Ports

Turn On Current	3 mA
Isolator Diode Drop	1.1 VDC
Resistor Power Max	.25W
Contact Resistance, Initial	.15 $\Omega$
Maximum Input Range	3 – 13 VDC/VAC
Maximum Input Current	50 mA

# Technical Specifications

## Environmental Specifications

Specification	Operating	Storage
Temperature Range	0° to 70° C (32° to 158° F)	-50° to 105° C (-58° to 221° F)
Humidity Range	10 to 90% R.H. Non-Condensing	10 to 90% R.H. Non-Condensing

## Manufacturing

All Sealevel Systems Printed Circuit boards are built to UL 94V0 rating and are 100% electrically tested. These printed circuit boards are solder mask over bare copper or solder mask over tin nickel.

## Physical Dimensions

PCB length	6.5" (16.5 cm)
PCB Height	4.2 (10.7 cm)



# Hardware Installation



Do not install the PCI Express board until the software has been successfully installed.

The ISO-16.PCIe does not need to be configured prior to installation.

Once you have installed the Seal/O Classic software, install the board into an available PCI Express slot and boot the computer. The Found New Hardware wizard will appear. The drivers that were installed during the software installation process will automatically be used to configure the adapter.

The following instructions are applicable to the Windows XP operating system and may vary depending on your version of Windows.

1. After the software installation is complete, install the ISO-16.PCIe into an available PCI Express slot and boot the computer.
2. A 'Found New Hardware' alert will appear above the system tray.

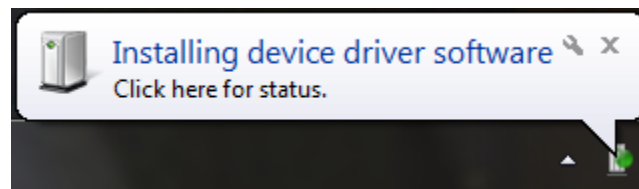

3. When the 'Found New Hardware' alert informs you that your hardware is installed and ready to use, you can proceed with verifying the installation to check functionality if necessary.

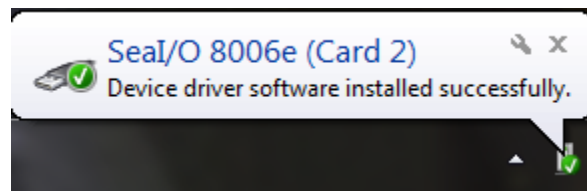

# HARDWARE INSTALLATION, CONTINUED

## Verifying Installation

To confirm that the digital I/O card has been successfully installed and recognized by your operating system, look in the Windows Device Manager.

To access Device Manager, follow the steps below:

1. Right click on the 'Computer' icon on your desktop or in the Start menu.
2. Click 'Manage' in the fly out menu to launch the 'Computer Management' console window.
3. In the left pane under 'System Tools,' click 'Device Manager.'
4. In right pane near the bottom, expand the 'Seal/O Device' section by clicking the '+' symbol. This shows the parent device is installed correctly.
5. You should see the card assignment listed as 'Seal/O 8006e' with the card number in parentheses. The card number will increment for each additional Seal/O device installed.

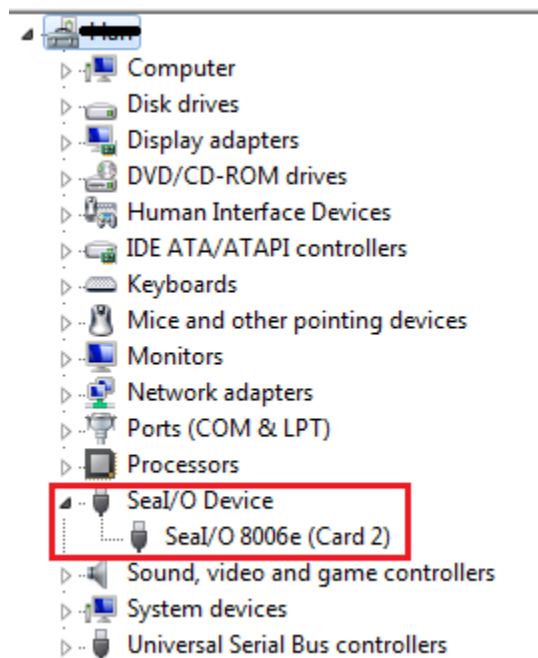

The ISO-16.PCie is now ready for use.

# Programming the ISO-32.PCLe

Sealevel's Seal/O Classic software is provided to assist in the development of reliable applications for the Sealevel Systems family of PCI and PCI Express digital I/O adapters. The Seal/O Classic software contains driver functions for use in accessing the I/O as well as helpful samples and utilities.

## Programming for Windows

The Seal/O Classic API (Application Programmer Interface) provides a variety of useful high-level function calls implemented in a Windows dynamic link library (DLL). The API is defined in the help file (Start/Programs/SealO/SealO Help) under "Application Programmers Interface." This help file also includes detailed information dealing with installation / removal of the software and information about latency, logic states, and device configuration.

For C language programmers we recommend using the API to access the ISO-32.PCLe. If you are programming in Visual Basic 6 or earlier, using the ActiveX control included with Seal/O is advised.

### Samples and Utilities

A variety of sample programs and utilities (both executable and source code) are included with Seal/O. Further documentation on these samples can be found by selecting "Start/Programs/SealO/Sample Application Description." Information about where the files are physically stored on your disk is also included in this same file.

## Programming for Linux

Seal/O for Linux consists of two major parts: a kernel module and a library. The kernel module is a simple IO pass-through device, allowing the library to handle the more sophisticated functions provided to Seal/O users. It is provided in a 'tarball' format and can easily be compiled and included in the kernel build.

## Digital I/O Interface

The ISO-16.PCLe provides two parallel input ports. The ports are organized as ports A, B. Port A and B are input ports interfaced to optically isolated inputs. Assuming an I/O address of 4000 Hex the following table shows the Port Addresses.

Base Address	Hex	Decimal	Mode
Port A Address	4000	16384	Optically Isolated Input Port
Port B Address	4001	16385	

# PROGRAMMING THE ISO-32.PCIE, CONTINUED

## Input Ports

Ports A and B are 8-bit input ports connected to optically isolated input sensors. Each sensor can be used to interface a voltage input and then sense whether the voltage is on or off. Each sensor is isolated (with respect to a common ground) from every other sensor, and isolated with respect to the host PC ground. This means that signals such as low-level AC line voltage, e.g., 12 or 24VAC, motor servo voltage, and control relay signals can be 'sensed', or read by the PC, without the risk of damage due to ground loops or ground faults.

Each sensor input pair has a current limiting resistor that is used to limit the input current to the opto-isolator. The opto-isolator has two 'back-to-back' diodes internally. This allows AC or DC signals to be sensed, regardless of polarity. When the applied voltage is high enough to cause the LED in the opto-isolator to turn-on, the output of the opto-isolator goes low (0 volts), and the signal is read as a low logic level (binary 0) by the PC. When the input signal is too low to turn on the opto-isolator, the output goes high, and the port bit is read by the PC as a high logic level (binary 1). While this is true at the hardware level, the Microsoft Windows driver gives the application the ability to use Positive or Negative Logic. This card defaults to Positive Logic and therefore the driver inverts the logic level BEFORE the information is returned to the application. Therefore, a voltage high enough to cause the LED to turn on will be read by the application as a logic high level.

The input impedance of each isolated input is approximately 560 ohms (factory default). The opto-isolator requires approximately 3mA to turn on. The maximum input current is 50mA. There are two things to consider when selecting the input resistor. The first is turn on voltage for the circuit to sense, and second is the maximum input voltage. Maximum input voltage must not provide too much power to the input resistor and must also not overdrive the opto-isolator input current specification. The following formulas apply:

$$\text{Turn on Voltage} = \text{diode drop} + (\text{turn on current}) \times (\text{resistance}) \text{ [Ex: } 1.1 + (.003) \times R \text{]}$$

$$\text{Input Current} = ((\text{input voltage}) - 1.1\text{V}) / (\text{resistor value})$$

$$\text{Maximum voltage} = 1.1 + \text{square root of } (.25(\text{resistor value}))$$

## PROGRAMMING THE ISO-32.PCIE, CONTINUED

The following table shows common input resistors and the ranges associated with each.

Input Resistor	Turn-On	Input Range	Max Input	Max Current
220Ω	1.8V	1.8 – 7.0V	8.5V	27mA
560Ω	2.8V	2.8 – 10.6V	12.9V	20mA
1KΩ	4.1V	4.1 – 13.8V	16.9V	15mA
2.2KΩ	7.7V	7.7 – 20.0V	24.5V	10mA
3.3KΩ	10.0V	10.0 – 24.0V	30.0V	9mA
4.7KΩ	15.2V	15.2 – 28.0V	35.0V	7mA



The turn-off voltage for all resistors is less than 1V. The opto-couplers require a minimum voltage to turn on and this voltage is dependent on the input resistor shown on the table above.

Increasing the input resistor accordingly can increase the maximum input voltage. Because socketed DIP resistors are utilized, they can easily be replaced with a different value. Sealevel can do this, if necessary.



The input circuits are not intended for monitoring 120-volt AC circuits. In addition to being too high a voltage for the circuits, it is dangerous to have that high a voltage on the card.

## PROGRAMMING THE ISO-32.PCIE, CONTINUED

### Input Ports Pin Assignments (DB-37 Female)

Inputs are interfaced via the DB-37 female connector on the supplied CA489 cable.

Signal Name	Port A Input Pin Pairs
Part A Bit 0	18,37
Part A Bit 1	17,36
Part A Bit 2	16,35
Part A Bit 3	15,34
Part A Bit 4	14,33
Part A Bit 5	13,32
Part A Bit 6	12,31
Part A Bit 7	11,30
Part B Bit 0	10,29
Part B Bit 1	9, 28
Part B Bit 2	8,27
Part B Bit 3	7,26
Part B Bit 4	6,25
Part B Bit 5	5,24
Part B Bit 6	4,23
Part B Bit 7	3,22
Ground	2,20,21
+5 Volts	19
+12 Volts	1

## PROGRAMMING THE ISO-32.PCIE, CONTINUED

### DB-78 Female Pin Assignments (Card Edge Connector)

Bit	Port A Pins	Port B Pins
0	55,74	47,66
1	54,73	46,65
2	53,72	45,64
3	52,71	44,63
4	51,70	43,62
5	50,69	42,61
6	49,68	41,60
7	48,67	40,59

GND	39,57,58	18,36,37
+12V	38	1
+5V	56	19

# PROGRAMMING THE ISO-32.PCIE, CONTINUED

## Direct Hardware Control

In systems where the user's program has direct access to the hardware (DOS) the tables that follow give the mapping and functions that the ISO-16.PCIE provides.

Function Available	Port	Address Hex	Port Type
RD	A	Base + 0	Optically Isolated Input Port
RD	B	Base + 1	

RD = Read

## Reading the Inputs

The inputs are active Low. If no voltage is applied across one of the differential inputs, it returns a one on that bit. If an AC or DC voltage is applied, it returns a zero on that bit.

## Register Description

All ports are set to input after reset or power up.

Address		Mode	D7	D6	D5	D4	D3	D2	D1	D0
Base+0	Input Port A	RD	PAD7	PAD6	PAD5	PAD4	PAD3	PAD2	PAD1	PAD0
Base+1	Input Port B	RD	PBD7	PBD6	PBD5	PBD4	PBD3	PBD2	PBD1	PBD0



# Example Circuits

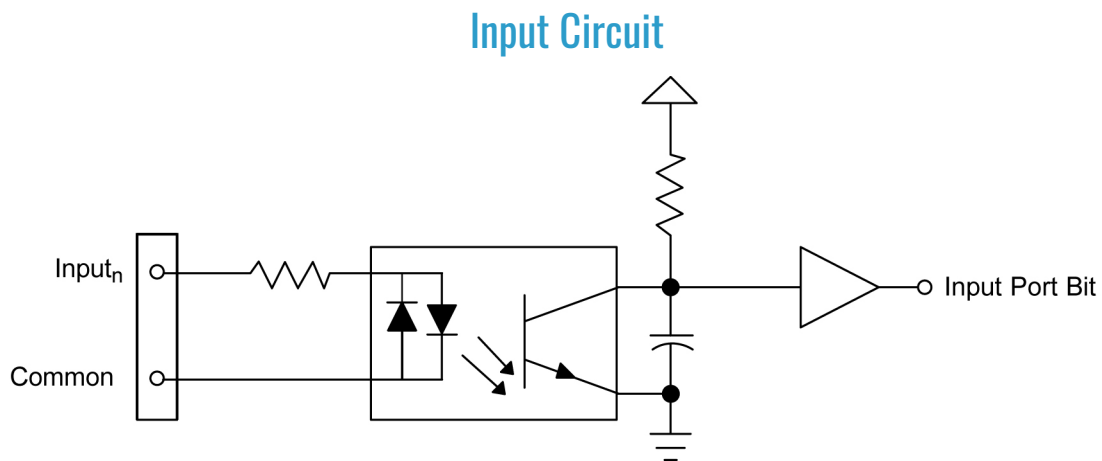

In the above circuit diagram,  $Input_n$  is one of the two Input Pair Pins from the table labeled Input Ports Pin Assignments. Common is the other pin listed in the Input Pair Pins entry. The polarity of the pair does not matter.

# Software Installation

## Operating System Installation

This section contains helpful information pertaining to the installation of supported Sealevel Systems, Inc. software packages. The [SealO software](#) includes drivers, utilities, and programming samples for Windows and Linux to aid in the development of reliable applications for the Sealevel Systems family of Digital I/O adapters.

### For Windows Users



Do not install the Adapter in the machine until the software has been fully installed.



Only users running Windows 7 or newer should utilize these instructions for accessing and installing the appropriate driver via Sealevel's website. If you are utilizing an operating system prior to Windows 7, please contact Sealevel by calling 864.843.4343 or emailing [support@sealevel.com](mailto:support@sealevel.com) to receive access to the proper driver download and installation instructions.

---

Begin by locating, selecting, and installing the correct software from the [Sealevel software driver database](#).

1. Type in the product part number (**8006e**) and select the product that appears below the search bar.
2. Sealevel software for Windows and Linux operating systems is also available at these links:
  - [Software for Windows](#)
  - [Software for Linux](#)
3. Choose the link for the desired software package and click on the 'Download File' link to download the current driver and follow the instructions on your screen.

SealO Software can also be downloaded from the 8006e-product page: [ISO-16.PCIE - PCI Express 16 Isolated Input Digital Interface \(3-13V\)](#)



Do not connect the hardware until the software has been successfully installed.



To install Sealevel software, you must log in as an administrator or have administrator privileges in Windows.

## Other Operating Systems



Refer to the appropriate section of the Serial Utilities Software.

## Software installation, continued

### Linux Installation

Refer to [Linux Archives - Sealevel](#). This link contains valuable information on installing your serial adapter in the various Linux releases. Also included is a series of files explaining proper Linux syntax and typical Linux serial implementations.

For additional software support, please call Sealevel Systems' Technical Support, (864) 843-4343. Our technical support is free and available from 8:00AM-5:00 PM Eastern Time, Monday through Friday. For email support contact: [support@sealevel.com](mailto:support@sealevel.com).

-  Most Sealevel Linux software is distributed as source code. To use the software, it must be compiled. Refer to the README file in each package for system prerequisites.
-  You must have administrative privileges to install the software. It is not necessary to have administrative privileges to build or use the software.
-  All command syntax is case sensitive.

# Appendix A – Handling Instructions

## ESD Warnings

### Electrostatic Discharges (ESD)

A sudden electrostatic discharge can destroy sensitive components. Proper packaging and grounding rules must therefore be observed. Always take the following precautions:

1. Transport boards and cards in electrostatically secure containers or bags.
2. Keep electrostatically sensitive components in their containers, until they arrive at an electrostatically protected workplace.
3. Only touch electrostatically sensitive components when you are properly grounded.
4. Store electrostatically sensitive components in protective packaging or on anti-static mats.

### Grounding Methods

The following measures help to avoid electrostatic damages to the device:

1. Cover workstations with approved antistatic material. Always wear a wrist strap connected to a properly grounded workplace.
2. Use antistatic mats, heel straps, and/or air ionizers for more protection.
3. Always handle electrostatically sensitive components by their edge or by their casing.
4. Avoid contact with pins, leads, or circuitry.
5. Turn off power and input signals before inserting and removing connectors or connecting test equipment.
6. Keep work area free of non-conductive materials such as ordinary plastic assembly aids and Styrofoam.
7. Use field service tools such as cutters, screwdrivers, and vacuum cleaners that are conductive.

# Appendix B – Troubleshooting

Sealevel Software is supplied with the Sealevel Systems adapter and will be used in the troubleshooting procedures. By using this software and following these simple steps, most common problems can be eliminated without the need to call Technical Support.

1. Install software first. After installing the software then proceed to adding the hardware. This places the required installation files in the correct locations.
2. Read this manual thoroughly before attempting to install the adapter in your system.
3. Use Device Manager under Windows to verify proper installation. Refer to the Verifying Hardware section of this manual for instructions.
4. Several utilities with source code are included to verify the functionality of the inputs and outputs and to aid in application development. To test the inputs, you need to supply the turn-on voltage with a minimum of 3mA (maximum input current is 50mA) to trigger an input. Consult the pin out diagrams to test at the card edge connector or at the end of the cable.
5. Use the VCTest to verify the basic I/O functionality of your digital I/O board. The source code is included to simplify application development in the programming language C.

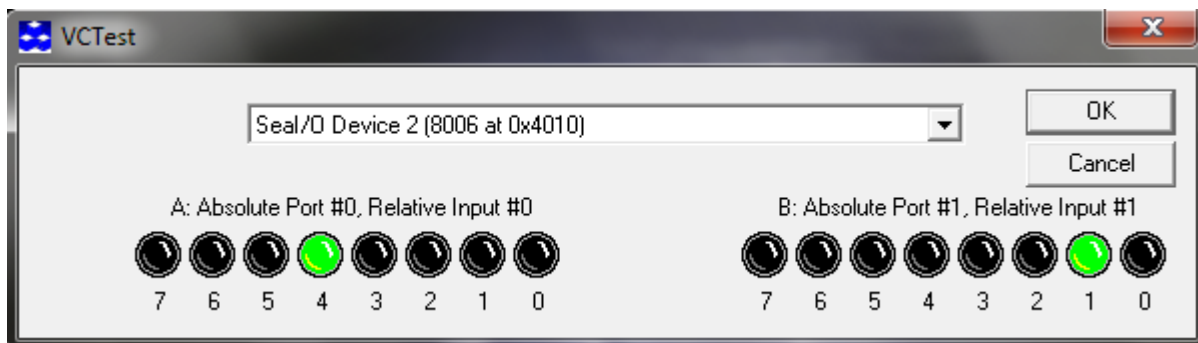

## APPENDIX B – TROUBLESHOOTING, CONTINUED

6. VBTest is another utility included with Seal/O Classic software. The source code is included to aid with Visual Basic application development.

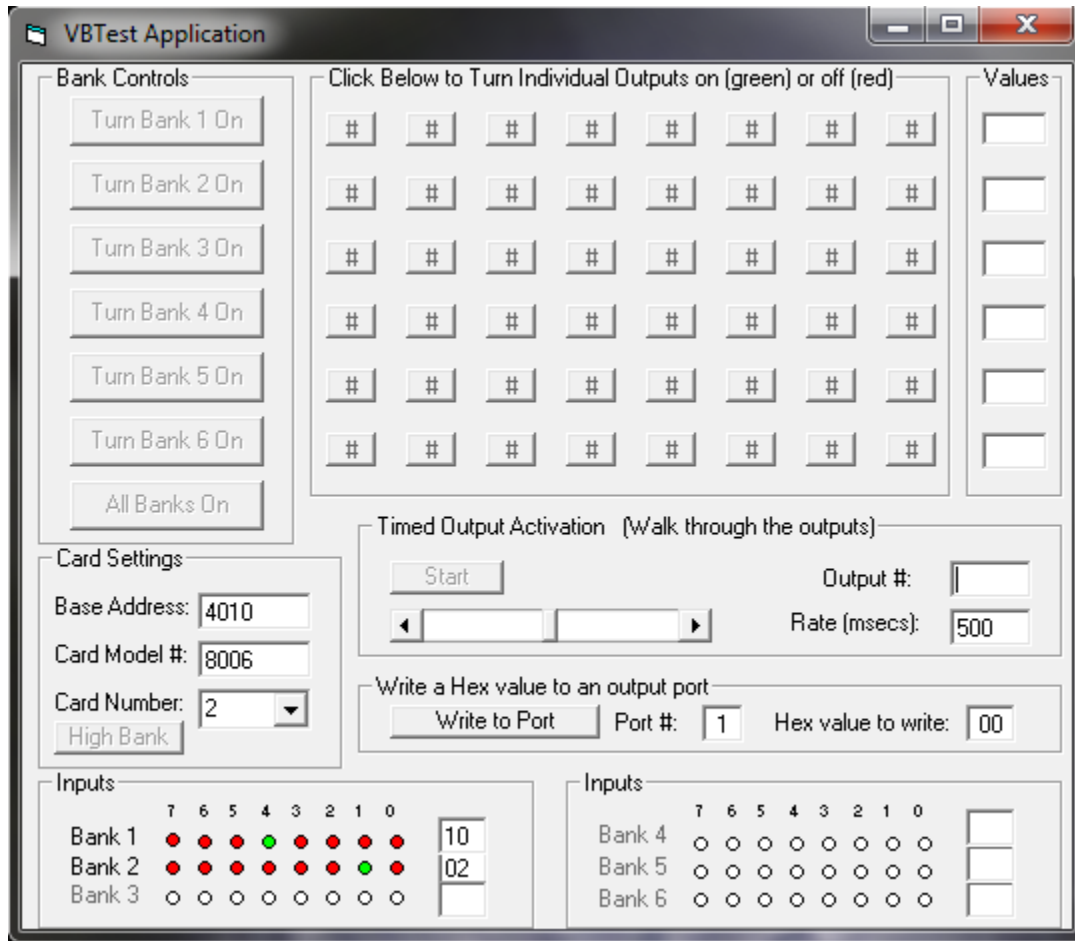

## APPENDIX B – TROUBLESHOOTING, CONTINUED

2. SealOTST is a command line utility that allows you to test the function calls from the Seal/O Classic API.

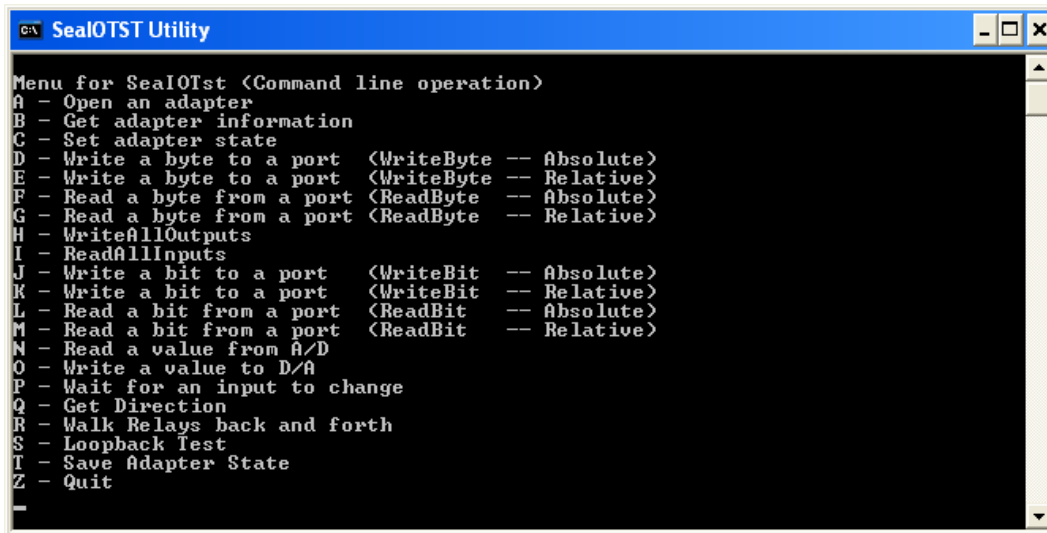

```
SealOTST Utility
Menu for SeaOTst <Command line operation>
A - Open an adapter
B - Get adapter information
C - Set adapter state
D - Write a byte to a port <WriteByte -- Absolute>
E - Write a byte to a port <WriteByte -- Relative>
F - Read a byte from a port <ReadByte -- Absolute>
G - Read a byte from a port <ReadByte -- Relative>
H - WriteAllOutputs
I - ReadAllInputs
J - Write a bit to a port <WriteBit -- Absolute>
K - Write a bit to a port <WriteBit -- Relative>
L - Read a bit from a port <ReadBit -- Absolute>
M - Read a bit from a port <ReadBit -- Relative>
N - Read a value from A/D
O - Write a value to D/A
P - Wait for an input to change
Q - Get Direction
R - Walk Relays back and forth
S - Loopback Test
T - Save Adapter State
Z - Quit
```

**N** The source code for all utilities is located in the following folder:  
C:\Program Files\SealO\Samples

**N** The API is documented in the SealO help file. Start → All Programs → SealO → SealO Help.  
Launch the help file and expand the Programmers Interface section.

If these steps do not solve your problem, please call Sealevel Systems' Technical Support, (864) 843-4343. Our technical support is free and available from 8:00 AM-5:00 PM Eastern Time, Monday through Friday. For email support contact: [support@sealevel.com](mailto:support@sealevel.com).

# Appendix C – How To Get Assistance

Please refer to: Appendix A – Troubleshooting Guide prior to calling Technical Support.

Begin by reading the Trouble Shooting Guide in Appendix A. If assistance is still needed, please see below.

When calling for technical assistance, please have your user manual and current adapter settings. If possible, please have the adapter installed in a computer ready to run diagnostics.

Sealevel Systems provides an FAQ section on its web site. Please refer to this to answer many common questions. This section can be found at <http://www.sealevel.com/faq.asp>.

Sealevel Systems maintains a web page on the Internet. Our home page address is [www.sealevel.com](http://www.sealevel.com). The latest software updates, and newest manuals are available via our web site.

Technical support is available Monday to Friday from 8:00 AM to 5:00 PM Eastern time. Technical support can be reached at (864) 843-4343.

**RETURN AUTHORIZATION MUST BE OBTAINED FROM SEALEVEL SYSTEMS BEFORE RETURNED MERCHANDISE WILL BE ACCEPTED. AUTHORIZATION CAN BE OBTAINED BY CALLING SEALEVEL SYSTEMS AND REQUESTING A RETURN MERCHANDISE AUTHORIZATION (RMA) NUMBER.**



# Appendix D - Drawing

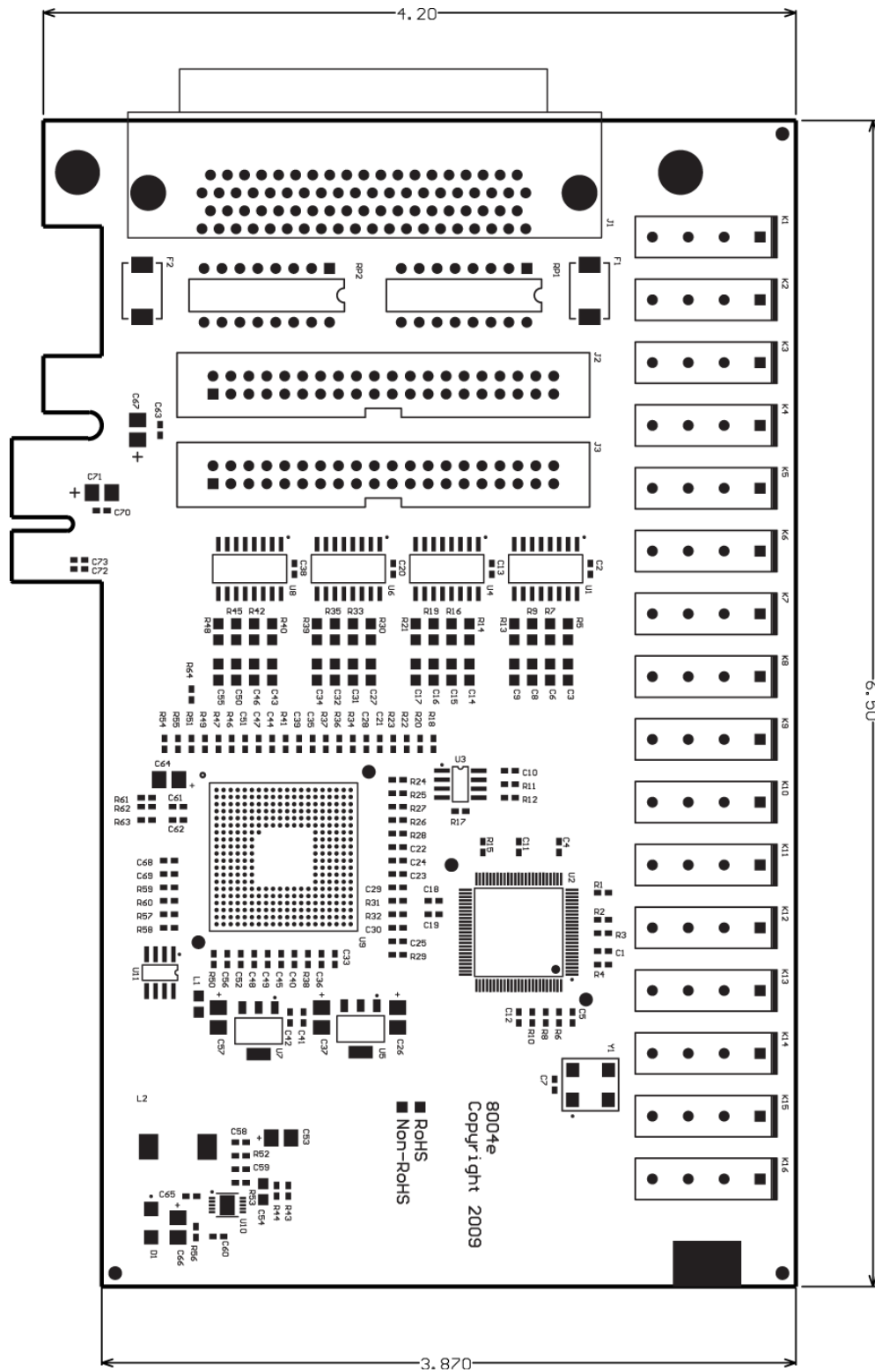

# Appendix E – Compliance Notices

## Federal Communications Commission (FCC) Statement



This equipment has been tested and found to comply with the limits for Class A digital device, pursuant to Part 15 of the FCC Rules. These limits are designed to provide reasonable protection against harmful interference when the equipment is operated in a commercial environment. This equipment generates, uses, and can radiate radio frequency energy and, if not installed and used in accordance with the instruction manual, may cause harmful interference to radio communications. Operation of this equipment in a residential area is likely to cause harmful interference in such case the user will be required to correct the interference at the user's expense.

## EMC Directive Statement



Products bearing the CE Label fulfill the requirements of the EMC directive (89/336/EEC) and of the low-voltage directive (73/23/EEC) issued by the European Commission. To obey these directives, the following European standards must be met:

- **EN55022 Class A** - "Limits and methods of measurement of radio interference characteristics of information technology equipment"
- **EN55024** - "Information technology equipment Immunity characteristics Limits and methods of measurement".



This is a Class A Product. In a domestic environment, this product may cause radio interference in which case the user may be required to take adequate measures to prevent or correct the interference.



Always use cabling provided with this product if possible. If no cable is provided or if an alternate cable is required, use high quality shielded cabling to maintain compliance with FCC/EMC directives.

# Warranty

Sealevel's commitment to providing the best I/O solutions is reflected in the Lifetime Warranty that is standard on all Sealevel manufactured I/O products. We are able to offer this warranty due to our control of manufacturing quality and the historically high reliability of our products in the field. Sealevel products are designed and manufactured at its Liberty, South Carolina facility, allowing direct control over product development, production, burn-in and testing. Sealevel achieved ISO-9001:2015 certification in 2018.

## Warranty Policy

Sealevel Systems, Inc. (hereafter "Sealevel") warrants that the Product shall conform to and perform in accordance with published technical specifications and shall be free of defects in materials and workmanship for the warranty period. In the event of failure, Sealevel will repair or replace the product at Sealevel's sole discretion. Failures resulting from misapplication or misuse of the Product, failure to adhere to any specifications or instructions, or failure resulting from neglect, abuse, accidents, or acts of nature are not covered under this warranty.

Warranty service may be obtained by delivering the Product to Sealevel and providing proof of purchase. Customer agrees to ensure the Product or assume the risk of loss or damage in transit, to prepay shipping charges to Sealevel, and to use the original shipping container or equivalent. Warranty is valid only for original purchaser and is not transferable.

This warranty applies to Sealevel manufactured Product. Product purchased through Sealevel but manufactured by a third party will retain the original manufacturer's warranty.

## Non-Warranty Repair/Retest

Products returned due to damage or misuse and Products retested with no problem found are subject to repair/retest charges. A purchase order or credit card number and authorization must be provided in order to obtain an RMA (Return Merchandise Authorization) number prior to returning Product.

## How to obtain an RMA (Return Merchandise Authorization)

If you need to return a product for warranty or non-warranty repair, you must first obtain an RMA number. Please contact Sealevel Systems, Inc. Technical Support for assistance:

Available	Monday – Friday, 8:00AM to 5:00PM EST
Phone	864-843-4343
Email	<a href="mailto:support@sealevel.com">support@sealevel.com</a>

## Trademarks

Sealevel Systems, Incorporated acknowledges that all trademarks referenced in this manual are the service mark, trademark, or registered trademark of the respective company.