

# ULTRA COMM+2i.PCLe

User Manual | 7203e

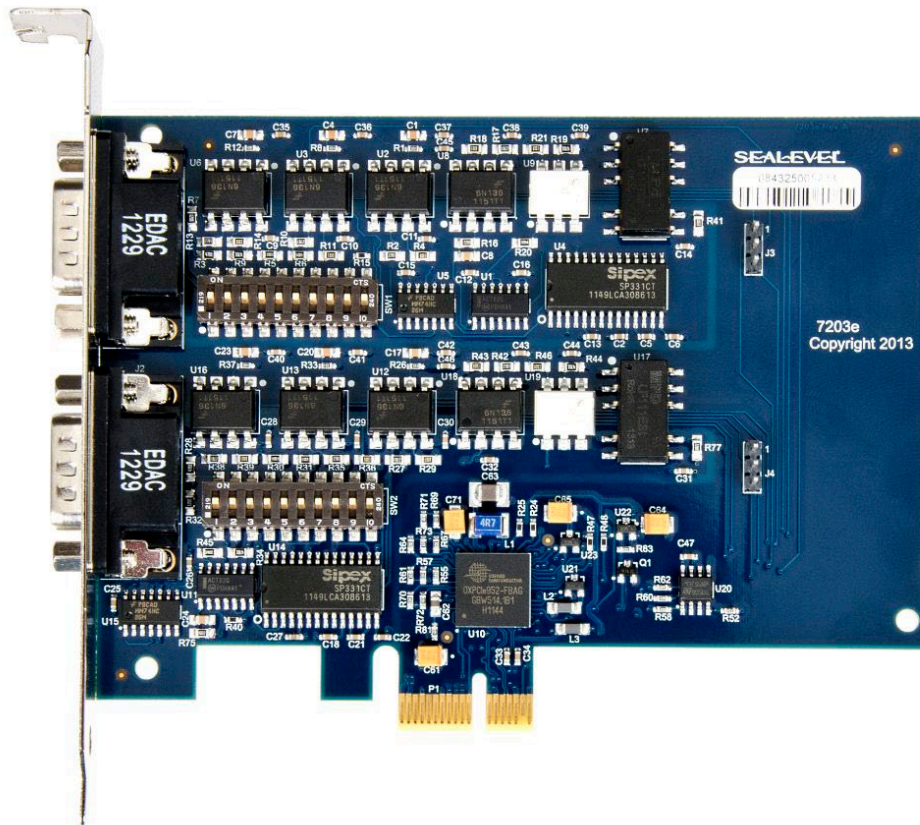

SEALEVEL®

# Contents

- CONTENTS..... 2
- INTRODUCTION ..... 3
- BEFORE YOU GET STARTED ..... 4
- CARD SETUP ..... 7
- INSTALLATION ..... 10
- HARDWARE INSTALLATION ..... 11
- TECHNICAL DESCRIPTION ..... 12
- TECHNICAL SPECIFICATIONS..... 13
- APPENDIX A – TROUBLESHOOTING..... 14
- APPENDIX B – SAFETY INSTRUCTIONS..... 17
- APPENDIX C – ELECTRICAL INTERFACE ..... 18
- APPENDIX D – ASYNCHRONOUS COMMUNICATIONS ..... 19
- APPENDIX E – GROUND LOOP PHENOMENON ..... 20
- APPENDIX F – MECHANICAL DRAWING ..... 21
- APPENDIX G – COMPLIANCE NOTICES ..... 22
- WARRANTY ..... 23
- .....

# Introduction

## Overview

The Sealevel Systems UltraCOMM+2i.PCIE is a two channel isolated PCIE Bus serial I/O adapter for the PC and compatibles. Utilizing the PLX OXPCIE952 with its industry leading 16C950 based 128 byte FIFOs, it provides two field selectable RS-232/422/485 serial ports supporting data rates up to 921.6K bps (RS-422/485).

Configure both ports as RS-232 for standard serial COM: port requirements. Choose the RS-422 mode for long distance device connections up to 4000ft. where noise immunity and high data integrity are essential. Select RS-485 and capture data from multiple peripherals in a RS-485 multidrop network. Up to 31 RS-485 devices can be connected to each port to automate your data collection. You can even mix the ports in any of the interface combinations to provide maximum flexibility to your application. Optional Terminal Block adapters are available to simplify field-wiring connections.

In both RS-232 and RS-422 modes, the card works seamlessly with the standard operating system serial driver. In RS-485 mode, our special auto-enable feature allows the RS-485 ports to be viewed by the operating system as a COM: port. This allows the standard COM: driver to be utilized for RS-485 communications. Our on-board hardware automatically handles the RS-485 driver enabled.

The UltraCOMM+2i.PCIE will operate on x1, x4, x8 or x16 PCIE bus slots.

## Features

- Each port individually configurable for RS-232, RS-422, or RS-485
- Isolation provides protection against transients and ground loops
  - Optically isolated serial ports
  - Galvanically isolated power to the transceiver
- 16C950 based buffered UARTs with 128-byte FIFOs
- Data rates to 921.6K bps
- Automatic RS-485 enable/disable
- The PCIE adapter includes two DB9M connectors

## Factory Default Settings

The UltraCOMM+2i.PCIE factory default settings are as follows:

Port #	Electrical Specification
Port 1	RS-422
Port 2	RS-422

To install the UltraCOMM+2i.PCIE using factory default settings, refer to the Installation section of the manual.

# Before You Get Started

## What's Included

The UltraCOMM+2i.PCIE is shipped with the following items. If any of these items are missing or damaged, please contact Sealevel for replacement.

- **UltraCOMM+2i.PCIE Isolated Serial Interface**

## Advisory Conventions



### **Warning**

The highest level of importance used to stress a condition where damage could result to the product, or the user could suffer serious injury.



### **Important**

The middle level of importance used to highlight information that might not seem obvious or a situation that could cause the product to fail.



### **Note**

The lowest level of importance used to provide background information, additional tips, or other non-critical facts that will not affect the use of the product.

## Optional Items

Depending upon your application, you are likely to find one or more of the following items useful with the 7203e. All items can be purchased from our website ([www.sealevel.com](http://www.sealevel.com)) by calling our sales team at (864) 843-4343.

<b>DB9 Female to DB9 Male Extension Cable, 72 inch Length (Item# CA127)</b>	
<p>The CA127 is a standard DB9F to DB9M serial extension cable. Extend a DB9 cable or locate a piece of hardware where it is needed with this six foot (72) cable. The connectors are pinned one-to-one, so the cable is compatible with any device or cable with DB9 connectors. The cable is fully shielded against interference and the connectors are molded to provide strain relief. Dual metal thumbscrews secure the cable connections and prevent accidental disconnection.</p>	
<b>9 Female to DB25 Male Standard RS-232 Modem Cable, 72 inch Length (Item# CA177)</b>	
<p>The CA177 is a standard AT-style RS-232 modem cable with a DB9 female connector on one end and a DB25 male connector on the other end. Simply connect the DB-9F connector to the DB9 serial port on your computer or host and then connect the DB-25M connector to your RS-232 serial modem or other compatible RS-232 serial device. The six foot cable is fully shielded with dual thumbscrews at each connector. The molded connectors integrate strain relief to prevent damage to the cable or connectors. All DB9 modem control signals are implemented, and the cable is pinned to EIA-232 standards.</p>	
<b>DB9 Female to DB9 Female, 72 inchLength - RS-422 207M SMPTE Cable (Item# CA190)</b>	
<p>The CA190 connects any Sealevel DB9 RS-422 device to a Sony (or compatible) 207M (SMPTE) 9 Pin connector.</p>	

### DB9 Female (RS-422) to DB25 Male (RS-530) Cable, 10 inch Length (Item# CA176)

DB9 Female (RS-422) to DB25 Male (RS-530) Cable, 10 inch Length. Convert any Sealevel RS-422 DB9 Male Async Adapter to an RS-530 DB25 Male pinout. Useful in situations where RS-530 cabling exists, and a multiport Sealevel RS-422 adapter is to be used.



## Terminal Blocks

### DB9 Female to 9 Screw Terminal Block (Item# TB05)

The TB05 terminal block breaks out a DB9 connector to 9 screw terminals to simplify field wiring of serial connections. It is ideal for RS-422 and RS-485 networks, yet it will work with any DB9 serial connection, including RS-232. The TB05 includes holes for board or panel mounting. The TB05 is designed to connect directly to Sealevel DB9 serial cards or any cable with a DB9M connector.



### al DB9 Female to 18 Screw Terminal Block (Item# TB06)

The TB05 terminal block breaks out a DB9 connector to 9 screw terminals to simplify field wiring of serial connections. It is ideal for RS-422 and RS-485 networks, yet it will work with any DB9 serial connection, including RS-232. The TB05 includes holes for board or panel mounting. The TB05 is designed to connect directly to Sealevel DB9 serial cards or any cable with a DB9M connector.



### DB9 Female to 5 Screw Terminal Block (RS-422/485) (Item# TB34)

The TB34 terminal block adapter offers a simple solution for connecting RS-422 and RS-485 field wiring to a serial port. The terminal block is compatible with 2-wire and 4-wire RS-485 networks and matches the RS-422/485 pin-out on Sealevel serial devices with DB9 male connectors. A pair of thumbscrews secures the adapter to the serial port and prevents accidental disconnection. The TB34 is compact and allows multiple adapters to be used on multi-port serial devices, such as Sealevel USB serial adapters, Ethernet serial servers and other Sealevel serial devices with two or more ports.



# Card Setup

## Address and IRQ Selection

The UltraCOMM+2i.PCIE is automatically assigned I/O addresses and IRQs by your motherboard BIOS or by a 'Plug-n-Play' Operating System. Adding or removing other hardware or moving the adapter to another slot may change the assignment of I/O addresses and IRQs.

## Clock Modes

The Ultra COMM+4.PCIE derives a 62.5MHz clock from the PCI express link which is divided by an 8 bit clock prescaler and a 16 bit clock divisor to provide a wide range of possible baud rates. Note that there are many combinations that can give the same result (e.g. Prescaler=1 and Divisor = 8, Prescaler =2 and Divisor = 4, or Prescaler=8 and Divisor = 1). As long as the calculated data rate is within +/- 2% you should communicate fine.

## Baud Rates

The following table shows some common data rates and the rates you should choose to achieve them when using the ULTRA COMM+4.PCIE.

For This Data Rate	Clock Prescaler	Choose This Divisor DLM:DLL
1200 bps	3.625	898
2400 bps	3.625	449
4800 bps	1.875	434
9600 bps	1.875	217
19.2K bps	1.375	148
38.4K bps	1.375	74
57.6K bps	22.625	3
115.2K bps	1	34
230.4K bps	1	17
460.8K bps	2.125	4
921.6K bps	2.125	2

## Electrical Interface Selection

Each port on the UltraCOMM+2i.PCie has the ability to be used as RS-232, RS-422 or RS-485. This is selectable via two DIP-switches, SW1 & SW2. Please use the following examples to configure your adapter.

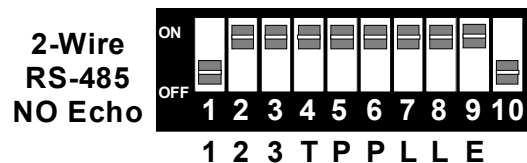
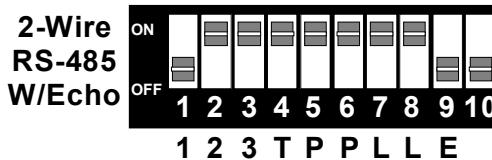
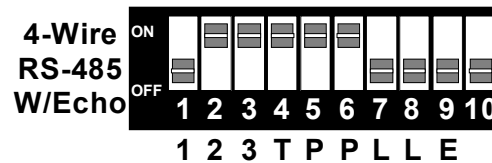
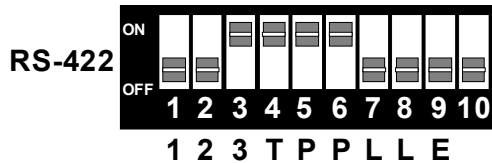
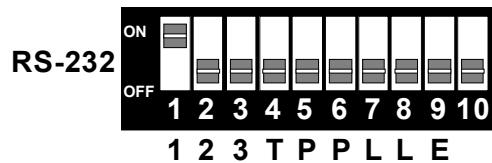

## Line Termination

Typically, each end of the RS-485 bus must have line-terminating resistors (RS-422 terminates at the receive end only). A 120-ohm resistor is across each RS-422/485 input in addition to a 1K-ohm pull-up/pull-down combination that biases the receiver inputs. Switches SW1 and SW2 allow the user to customize this interface to their specific requirements. Each switch position corresponds to a specific portion of the interface. If multiple UltraCOMM+2i.PCie adapters are configured in a RS-485 network, only the boards on each end should have jumpers T, P & P ON. Refer to the following table for each position's operation:

Name	Function
T	Adds or removes the 120 ohm termination.
PU	Adds or removes the 1K ohm pull-down resistor in the RS-422/RS-485 receiver circuit (Receive data only).
PD	Adds or removes the 1K ohm pull-up resistor in the RS-422/RS-485 receiver circuit (Receive data only).
L	Connects the TX+ to RX+ for RS-485 two wire operation.
L	Connects the TX- to RX- for RS-485 two wire operation.

## RS-485 Enable Modes

RS-485 is ideal for multi-drop or network environments. RS-485 requires a tri-state driver that will allow the electrical presence of the driver to be removed from the line. The driver is in a tri-state or high impedance condition when this occurs. Only one driver may be active at a time and the other driver(s) must be tri-stated. The output modem control signal Request To Send (RTS) is typically used to control the state of the driver. Some communication software packages refer to RS-485 as RTS enable or RTS block mode transfer.

One of the features of the 7203e is the ability to effectively use the UltraCOMM+2i.PC1e in an RS-485 application with existing (i.e. standard RS-232) application software.

Jumpers J3 and J4 are used to control the RS-485 mode functions for the driver circuit. Placing a .100" 2 position shunt on pins 1 and 2 allows the RTS modem control signal to enable the RS-485 interface and provides backward compatibility with existing software products. Placing a .100" 2 position shunt (jumper) on pins 2 and 3 selects the 'Auto' enable feature. The Auto enable feature automatically enables/disables the RS-485 interface.

The RS-485 'Echo' is the result of connecting the receiver inputs to the transmitter outputs. Every time a character is transmitted; it is also received. This can be beneficial if the software can handle echoing (i.e. using received characters to throttle the transmitter) or it can confuse the system if the software does not. Position 9 of SW1 and SW2 is used to control the RS-485 enable/disable functions for the receiver circuit. To select the 'No Echo' mode place switch position 9 to the 'On' position.

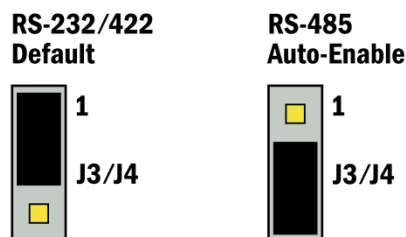

# Installation

## Software Installation

### WINDOWS INSTALLATION



Do not install the hardware until the software has been fully installed.



Only users running Windows 7 or newer should utilize these instructions for accessing and installing the appropriate driver via Sealevel's website. If you are utilizing an operating system prior to Windows 7, please contact Sealevel by calling 864.843.4343 or emailing [support@sealevel.com](mailto:support@sealevel.com) to receive access to the proper driver download and installation instructions.

1. Begin by locating, selecting, and installing the correct software from the [Sealevel software driver database](#).
2. Type in or select the part number (**#7203e**) for the adapter from the listing.
3. Select "Download Now" for SeaCOM for Windows.
4. The setup files will automatically detect the operating environment and install the proper components. Follow the information presented on the screens that follow.
5. A screen may appear with text similar to: "The publisher cannot be determined due to the problems below: Authenticode signature not found." Please click the 'Yes' button and proceed with the installation. This declaration simply means that the operating system is not aware of the driver being loaded. It will not cause any harm to your system.
6. During setup, the user may specify installation directories and other preferred configurations. This program also adds entries to the system registry that are necessary for specifying the operating parameters for each driver. An uninstall option is also included to remove all registry/INI file entries from the system.
7. The software is now installed, and you can proceed with the hardware installation.
8. Refer to the Physical Installation section to connect and install your adapter.



All Sealevel Systems software drivers have been fully tested by Sealevel. Clicking 'OK' will not harm your system.



This is a notification that if you are upgrading from a previous driver version, you should remove the associated Device Manager hardware entries and reinstall the adapter after installing the SeaCOM software.

## LINUX SUPPORT

The 7203e is supported natively in Linux kernels 2.6.28 and later.

## UPGRADING TO THE CURRENT SEACOM DRIVER

1. Download the current driver using the instructions from above. Please take note of the destination directory it will save to.
2. Uninstall the currently loaded driver SeaCOM driver found in the Control Panel. Prior to Windows Vista SeaCOM will be populated in 'Add/Remove Programs' list. In Vista and newer OSs it will be found in the 'Programs and Features' list.
3. Navigate to the Device Manager and remove the Sealevel adapter by right clicking on the line item choosing 'Uninstall'. Depending on your product, it can be found under either 'Multiport Serial adapters' or 'Universal Serial Bus controllers'.
4. Single port ISA cards and PCMCIA cards will need to be uninstalled under 'Ports (COM & LPT)'.
5. In the Device Manager under 'Action', choose 'Scan for Hardware changes'. This will prompt the installation of the adapter and associate it with the newly installed SeaCOM driver.

# Hardware Installation

The ULTRA COMM+2I.PCIe can be installed in any of the PCI expansion slots and contains several jumper straps for each port that must be set for proper operation.

1. Turn off PC power. Disconnect the power cord.
2. Remove the PC case cover.
3. Locate an available PCI slot and remove the blank metal slot cover.
4. Gently insert the ULTRA COMM+2I.PCIe into the slot. Make sure that the adapter is seated properly.
5. Replace the screw.
6. Replace the cover.
7. Connect the power cord.

Installation is complete.

# Technical Description

The Sealevel Systems UltraCOMM+2i.PCIE provides a PCIE interface adapter with 2 optically isolated asynchronous serial ports which provide a versatile interface, field selectable as RS-232 for modems, printers, and plotters, as well as RS-422/485 for industrial automation and control applications. Isolation is important in installations where the equipment being connected to the PC is either far from the PC, or on a different power transformer circuit. Ground loop current is a commonly neglected and misunderstood phenomenon that leads to data loss and the destruction of communications interfaces.

The UltraCOMM+2i.PCIE utilizes the PLX OXPCIE952 with its 16C950 based 128 byte FIFOs. This chip features programmable baud rates, data format, interrupt control and industry leading 128-byte FIFOs.

## Connector Pin Assignments

### RS-232

Name	Pin #	Mode
TD Transmit Data	3	Output
RTS Request To Send	7	Output
GND Ground	5	
RD Receive Data	2	Input
CTS Clear To Send	8	Input



These assignments meet EIA/TIA/ANSI-574 DTE for DB-9 type connectors.

### RS-422/485

Signal	Name	Pin #	Mode
GND	Ground	5	
TX +	Transmit Data Positive	4	Output
TX-	Transmit Data Negative	3	Output
RTS+	Request To Send Positive	6	Output
RTS-	Request To Send Negative	7	Output
RX+	Receive Data Positive	1	Input
RX-	Receive Data Negative	2	Input
CTS+	Clear To Send Positive	9	Input
CTS-	Clear To Send Negative	8	Input

# Technical Specifications

## Environmental Specifications

Specification	Operating	Storage
Temperature Range	0° to 50° C (32° to 122° F)	-40° to 105° C (-40° to 221° F)
Humidity Range	10 to 90% R.H. Non-Condensing	10 to 90% R.H. Non-Condensing

## MTBF

Mean Time Between Failure	800,000 hours
---------------------------	---------------

## Manufacturing

All Sealevel Systems Printed Circuit boards are built to UL 94V0 rating and are 100% electrically tested. These printed circuit boards are solder mask over bare copper or solder mask over tin nickel.

## Power Consumption

Supply line	+3.3 VDC	+12 VDC
Rating	130 mA	170 mA

## Physical Dimensions

Board length	4.875 inches (12.38 cm)
Board height including Goldfingers	3.677 inches (9.34 cm)
Board height excluding Goldfingers	3.178 inches (8.06 cm)

# Appendix A – Troubleshooting

Once you have confirmed that the serial adapter COM ports are listed in Device Manager, use the Sealevel WinSSD utility to verify communications. Detailed help is included in the WinSSD utility.

Please set the adapters Electrical Interface for either RS-232 or RS-422.

If you have a loopback plug, put it on the adapter connector. If you do not have a loopback plug, you can use female jumper wires to make the connection to verify the functionality.

RS-232 requires pins 2 (Receive) & 3 (Transmit) to be jumpered as shown in this graphic:

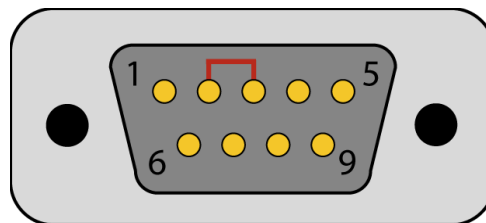

If you do not have a loopback plug or jumper wires handy, you can use a metal device such as a knife, screwdriver, key, or paperclip to short pins two and three.

RS-422 requires pins 1 & 4 (Receive + and Transmit +) and also pins 2 & 3 (Receive - and Transmit -) to be jumpered as shown in this graphic:

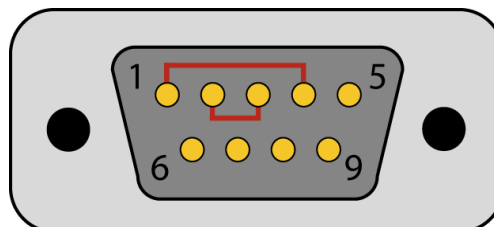

To test communications, launch the WinSSD utility in the SeaCOM folder in the 'Start' menu.

On the 'Port Information' tab, select the associated COM port and click the 'Open' button.

This will first open the COM port. From this tab the port can also be closed (See image below). Click the 'Settings' button to open the COM Port Properties dialog box. This will allow the Port Settings to be altered.

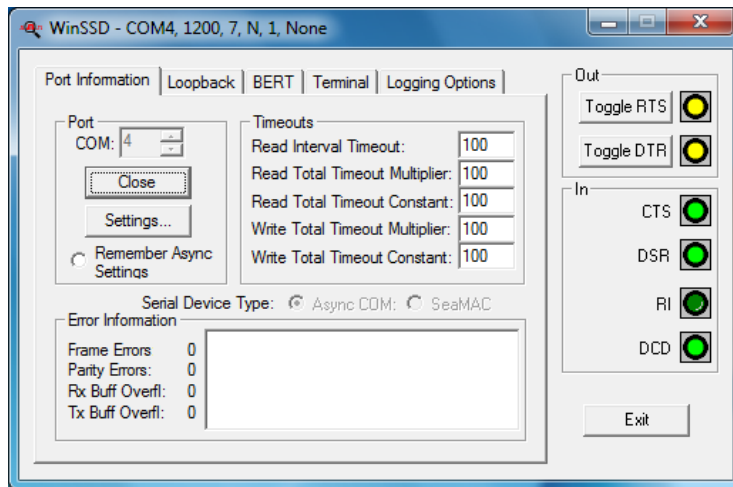

Change your parameters to 9600 bits per second, 8 data bits, no parity, 1 stop bit, and no flow control, as pictured below.

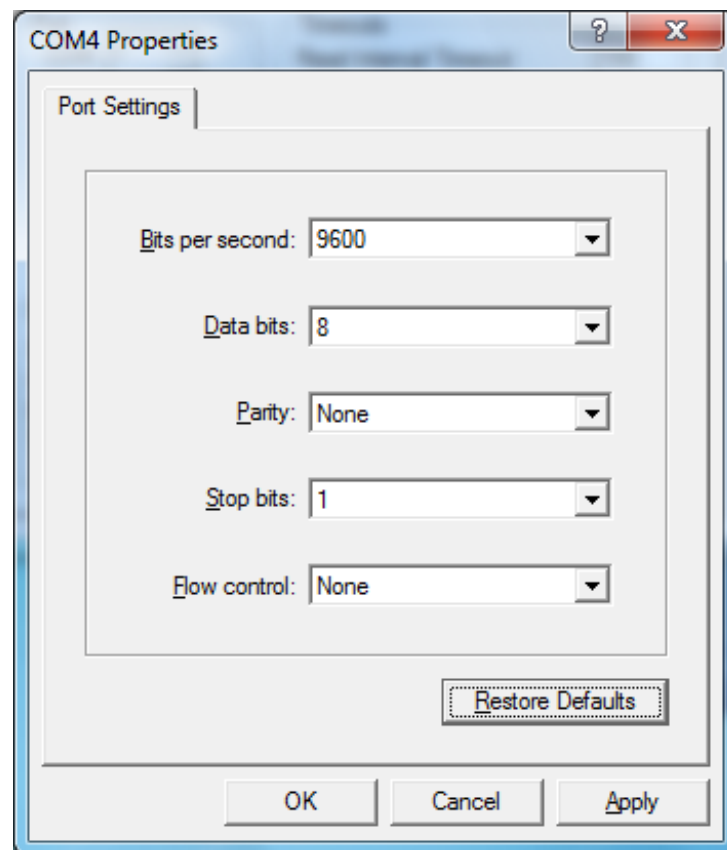

Click 'Apply' and 'OK'.

In the main WinSSD window, click on the 'BERT' tab (Bit Error Rate test).

Click on the 'Start' button.

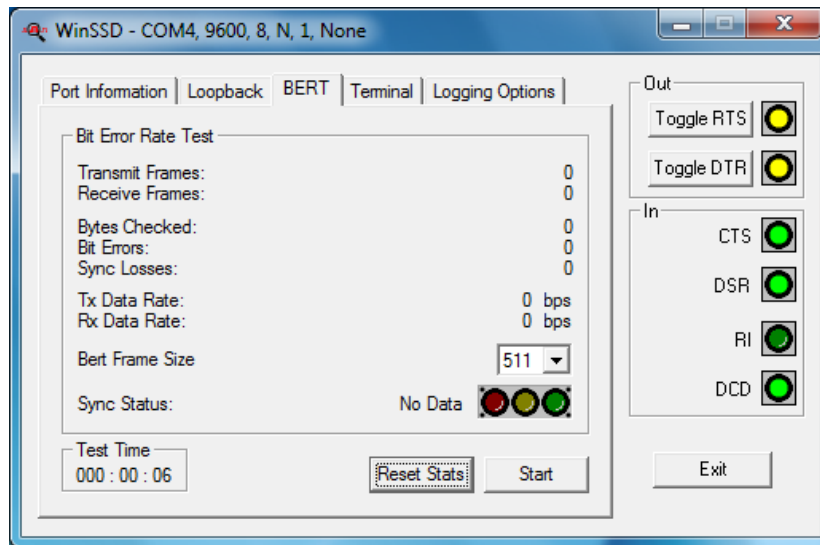

If the COM port is properly working, the Sync Status green light will glow, and the Transmit Frames and Receive Frames will increase. The Tx and Rx Data Rates will show the calculated data rate.

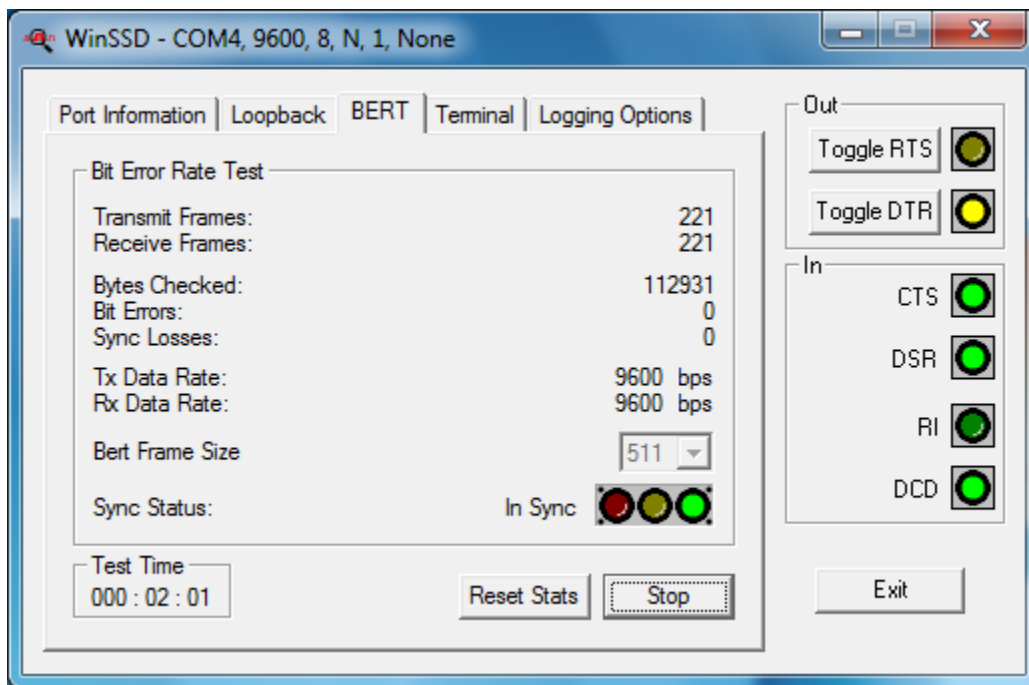

This verifies that the adapter is working properly. You can continue testing this port with different configurations or proceed with testing other ports, if necessary.

# Appendix B – Safety Instructions

## ESD Warnings

### ELECTROSTATIC DISCHARGES (ESD)

A sudden electrostatic discharge can destroy sensitive components. Proper packaging and grounding rules must therefore be observed. Always take the following precautions:

1. Transport boards and cards in electrostatically secure containers or bags.
2. Keep electrostatically sensitive components in their containers until they arrive at an electrostatically protected workplace.
3. Only touch electrostatically sensitive components when you are properly grounded.
4. Store electrostatically sensitive components in protective packaging or on anti-static mats.

### GROUNDING METHODS

The following measures help to avoid electrostatic damages to the device:

1. Cover workstations with approved antistatic material. Always wear a wrist strap connected to a properly grounded workplace.
2. Use antistatic mats, heel straps, and/or air ionizers for more protection.
3. Always handle electrostatically sensitive components by their edge or by their casing.
4. Avoid contact with pins, leads, or circuitry.
5. Turn off power and input signals before inserting and removing connectors or connecting test equipment.
6. Keep work area free of non-conductive materials such as ordinary plastic assembly aids and Styrofoam.
7. Use field service tools such as cutters, screwdrivers, and vacuum cleaners that are conductive.

# Appendix C – Electrical Interface

## RS-232

Quite possibly the most widely used communication standard is RS-232. This implementation has been defined and revised several times and is often referred to as RS-232 or EIA/TIA-232. The IBM PC computer defined the RS-232 port on a 9 pin D sub connector and subsequently the EIA/TIA approved this implementation as the EIA/TIA-574 standard. This standard is defined as the 9-Position Non-Synchronous Interface between Data Terminal Equipment and Data Circuit-Terminating Equipment Employing Serial Binary Data Interchange. Both implementations are in widespread use and will be referred to as RS-232 in this document. RS-232 is capable of operating at data rates up to 20 Kbps at distances less than 50 ft. The absolute maximum data rate may vary due to line conditions and cable lengths. RS-232 is a single ended or unbalanced interface, meaning that a single electrical signal is compared to a common signal (ground) to determine binary logic states. The RS-232 and the EIA/TIA-574 specification define two types of interface circuits, Data Terminal Equipment (DTE) and Data Circuit-Terminating Equipment (DCE). The ULTRA COMM+2I.PCI is a DTE device.

## RS-422

The RS-422 specification defines the electrical characteristics of balanced voltage digital interface circuits. RS-422 is a differential interface that defines voltage levels and driver/receiver electrical specifications. On a differential interface, logic levels are defined by the difference in voltage between a pair of outputs or inputs. In contrast, a single ended interface, for example RS-232, defines the logic levels as the difference in voltage between a single signal and a common ground connection. Differential interfaces are typically more immune to noise or voltage spikes that may occur on the communication lines. Differential interfaces also have greater drive capabilities that allow for longer cable lengths. RS-422 is rated up to 10 Megabits per second and can have cabling 4000 feet long. RS-422 also defines driver and receiver electrical characteristics that will allow 1 driver and up to 32 receivers on the line at once. RS-422 signal levels range from 0 to +5 volts. RS-422 does not define a physical connector.

## RS-485

RS-485 is backwardly compatible with RS-422; however, it is optimized for party-line or multi-drop applications. The output of the RS-422/485 driver is capable of being Active (enabled) or Tri-State (disabled). This capability allows multiple ports to be connected in a multi-drop bus and selectively polled. RS-485 allows cable lengths up to 4000 feet and data rates up to 10 Megabits per second. The signal levels for RS-485 are the same as those defined by RS-422. RS-485 has electrical characteristics that allow for 32 drivers and 32 receivers to be connected to one line. This interface is ideal for multi-drop or network environments. RS-485 tri-state driver (not dual-state) will allow the electrical presence of the driver to be removed from the line. Only one driver may be active at a time and the other driver(s) must be tri-stated. RS-485 can be cabled in two ways, two wire and four wire mode. Two wire mode does not allow for full duplex communication and requires that data be transferred in only one direction at a time. For half-duplex operation, the two transmit pins should be connected to the two receive pins (Tx+ to Rx+ and Tx- to Rx-). Four wire mode allows full duplex data transfers. RS-485 does not define a connector pin-out or a set of modem control signals. RS-485 does not define a physical connector.

# Appendix D – Asynchronous Communications

Serial data communications implies that individual bits of a character are transmitted consecutively to a receiver that assembles the bits back into a character. Data rate, error checking, handshaking, and character framing (start/stop bits) are pre-defined and must correspond at both the transmitting and receiving ends.

Asynchronous communications is the standard means of serial data communication for PC compatibles and PS/2 computers. The original PC was equipped with a communication or COM: port that was designed around an 8250 Universal Asynchronous Receiver Transmitter (UART). This device allows asynchronous serial data to be transferred through a simple and straightforward programming interface. A start bit, followed by a pre-defined number of data bits (5, 6, 7, or 8) defines character boundaries for asynchronous communications. The end of the character is defined by the transmission of a pre-defined number of stop bits (usually 1, 1.5 or 2). An extra bit used for error detection is often appended before the stop bits.

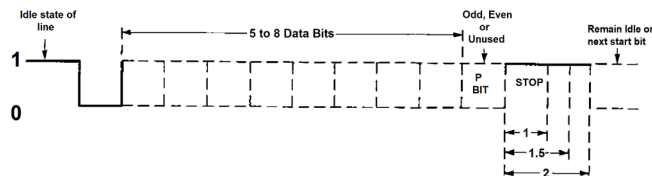

Figure 1 - Asynchronous Communications Bit Diagram

This special bit is called the parity bit. Parity is a simple method of determining if a data bit has been lost or corrupted during transmission. There are several methods for implementing a parity check to guard against data corruption. Common methods are called (E)ven Parity or (O)dd Parity. Sometimes parity is not used to detect errors on the data stream. This is referred to as (N)o parity. Because each bit in asynchronous communications is sent consecutively, it is easy to generalize asynchronous communications by stating that each character is wrapped (framed) by pre-defined bits to mark the beginning and end of the serial transmission of the character. The data rate and communication parameters for asynchronous communications have to be the same at both the transmitting and receiving ends. The communication parameters are baud rate, parity, number of data bits per character, and stop bits (i.e., 9600,N,8,1).

# Appendix E – Ground Loop Phenomenon

## What is Ground Loop?

Ground loop Phenomenon occurs when two (or more) pieces of equipment are connected together with a common ground and a different ground potential exists at each location. This current can cause the connected equipment to experience noise that in turn causes data transmission errors. In the extreme this ground current can cause equipment malfunction or even destruction.

## Cabling Recommendations

When connecting the ULTRA COMM+2I.PCI in a RS-485 network, care should be taken that both ends of the network are not isolated from ground (see Figure 8). This “floating” ground condition could cause the capacitive or inductive coupling of voltages that will cause a breakdown in the DC to DC converter circuit or in the opto-isolator circuit. This condition will cause data errors and possibly destruction of the receiver circuit.

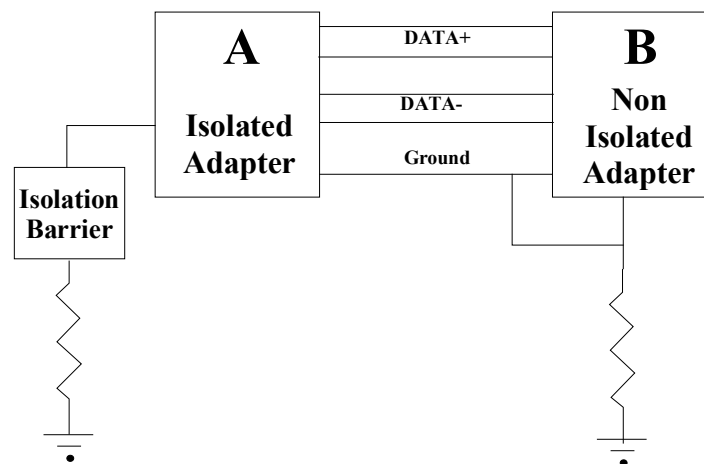



# Appendix G – Compliance Notices

## Federal Communications Commission (FCC) Statement



This equipment has been tested and found to comply with the limits for a Class A digital device, pursuant to part 15 of the FCC Rules. Operation is subject to the following two conditions: (1) This device may not cause harmful interference, and (2) this device must accept any interference received, including interference that may cause undesired operation.

## ISED Canada

- **CAN ICES-003(A) / NMB-003(A)**

## EMC Directive Statement



This equipment has been evaluated or tested and found in compliance with the requirements of the following directives issued by the European Commission:

- EMC Directive **2014/30/EU**
- RoHS Directive **2011/65/EU + (EU) 2015/863**



CE marking is recognized in the UK as an acceptable method of demonstrating compliance for certain categories of products, including the one described in this manual.



This is a Class A Product. In a domestic environment, this product may cause radio interference in which case the user may be required to take adequate measures to prevent or correct the interference.



Always use the cabling provided with this product if possible. If no cable is provided or if an alternate cable is required, use high quality shielded cabling to maintain compliance with FCC/EMC directives.

# Warranty

Sealevel's commitment to providing the best I/O solutions is reflected in the Lifetime Warranty that is standard on all Sealevel manufactured I/O products. We are able to offer this warranty due to our control of manufacturing quality and the historically high reliability of our products in the field. Sealevel products are designed and manufactured at its Liberty, South Carolina facility, allowing direct control over product development, production, burn-in and testing. Sealevel achieved ISO-9001:2015 certification in 2018.

## Warranty Policy

Sealevel Systems, Inc. (hereafter "Sealevel") warrants that the Product shall conform to and perform in accordance with published technical specifications and shall be free of defects in materials and workmanship for the warranty period. In the event of failure, Sealevel will repair or replace the product at Sealevel's sole discretion. Failures resulting from misapplication or misuse of the Product, failure to adhere to any specifications or instructions, or failure resulting from neglect, abuse, accidents, or acts of nature are not covered under this warranty.

Warranty service may be obtained by delivering the Product to Sealevel and providing proof of purchase. Customer agrees to ensure the Product or assume the risk of loss or damage in transit, to prepay shipping charges to Sealevel, and to use the original shipping container or equivalent. Warranty is valid only for original purchaser and is not transferable.

This warranty applies to Sealevel manufactured Product. Product purchased through Sealevel but manufactured by a third party will retain the original manufacturer's warranty.

## Non-Warranty Repair/Retest

Products returned due to damage or misuse and Products retested with no problem found are subject to repair/retest charges. A purchase order or credit card number and authorization must be provided in order to obtain an RMA (Return Merchandise Authorization) number prior to returning the Product.

## How to obtain an RMA (Return Merchandise Authorization)

If you need to return a product for warranty or non-warranty repair, you must first obtain an RMA number. Please contact Sealevel Systems, Inc., Technical Support for assistance:

Available	Monday – Friday, 8:00AM to 5:00PM EST
Phone	864-843-4343
Email	<a href="mailto:support@sealevel.com">support@sealevel.com</a>

## Trademarks

Sealevel Systems, Incorporated acknowledges that all trademarks referenced in this manual are the service mark, trademark, or registered trademark of the respective company.