

# REL-32

User Manual | 3098

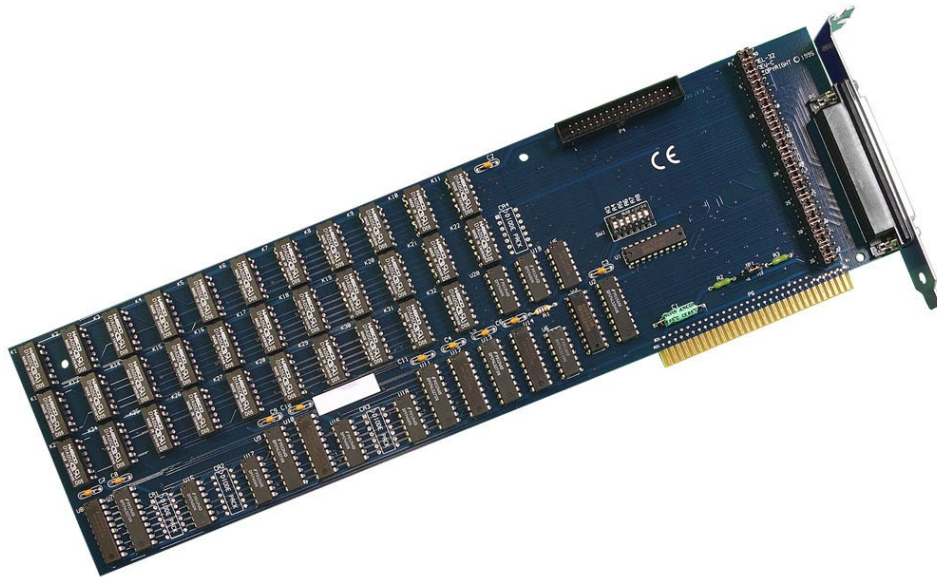

**SEALEVEL®**

# Contents

CONTENTS ..... 2

INTRODUCTION ..... 3

BEFORE YOU GET STARTED ..... 4

CARD SETUP ..... 6

INSTALLATION ..... 9

PROGRAMMING THE REL-32 ..... 12

ELECTRICAL CHARACTERISTICS ..... 19

SPECIFICATIONS ..... 20

EXAMPLE CIRCUITS ..... 21

APPENDIX A – TROUBLESHOOTING ..... 22

APPENDIX B – HOW TO GET ASSISTANCE ..... 23

APPENDIX C – SILK SCREEN – 3098 PCB ..... 24

APPENDIX D – COMPLIANCE NOTICES ..... 25

WARRANTY ..... 26

# Introduction

## Overview

The REL-32 provides 32 reed relays that can switch power, data, or other electronic signals for control applications. The outputs provide high quality, long life, low current (10 Watt maximum), dry contact switch closures. Reed relays are well suited for low current applications. The relays are normally open and will close when energized.

The REL-32 is designed to be used with a variety of Operating Systems including Windows 98/NT/ME/2000/XP, Linux, and DOS. The Seal/O API (Application Programmer Interface) included in the software available for the REL-32 provides a variety of useful high-level function calls implemented as a Windows dynamic link library (DLL) and as a Linux kernel module and library. In addition to the API, Seal/O includes sample code and utilities to simplify software development.

## Other Sealevel ISA Digital I/O Products

Model No.	Part No.	Description
DIO-16	(P/N 3096)	- 8 Reed Relay Outputs / 8 Opto-Isolated Inputs
ISO-16	(P/N 3094)	- 16 Optically Isolated Inputs
REL-16	(P/N 3095)	- 16 Reed Relay Outputs
DIO-32B	(P/N 3093)	- 16 Reed Relay Outputs / 16 Opto-Isolated Inputs
PIO-48	(P/N 4030)	- 48 TTL Inputs/Outputs

# Before You Get Started

## What's Included

The REL-32 is shipped with the following items. If any of these items is missing or damaged, please contact Sealevel for replacement.

- **REL-32 Adapter**
- **CA1752 6' DB78M to dual DB37M Cable**

## Advisory Conventions



### **Warning**

The highest level of importance used to stress a condition where damage could result to the product, or the user could suffer serious injury.



### **Important**

The middle level of importance used to highlight information that might not seem obvious or a situation that could cause the product to fail.





### **Note**

The lowest level of importance used to provide background information, additional tips, or other non-critical facts that will not affect the use of the product.

## Optional Items

Depending upon your application, you are likely to find one or more of the following items useful for interfacing the REL-32 to real-world signals. All items can be purchased from our website ([www.sealevel.com](http://www.sealevel.com)) or by calling (864) 843-4343.

DB-37 Male to DB-37 Female 6' Extension Cable (Item# CA112)	
<p>The CA112 is a cable that extends the DB-37 connector on the CA172 cable an additional six feet and is pinned one-to-one.</p>	
DB-37 Male/Female Terminal Block (Item# TB02-KT)	
<p>Break out serial and digital connectors to 37 screw terminals for easy field connection. The TB02 terminal block is designed with both DB-37 male and female connectors, therefore; it can be used with any DB-37 board regardless of the board's port gender.</p>	
Cable and Terminal Block Kit (Item# KT101)	
<p>For convenient and easier ordering, the KT101 includes the TB02-KT terminal block and CA112 cable in a single kit.</p>	

# Card Setup

The REL-32 contains several jumper straps for each port that must be set for proper operation.

## Address Selection

The REL-32 occupies 4 consecutive I/O locations. The DIP-switch (SW1) is used to set the base address for these locations. Be careful when selecting the base address as some selections conflict with existing PC ports. The following table shows several examples that usually do not cause a conflict.

Address	Binary	Switch Settings					
		1	2	3	4	5	6
280-283	000010	Off	On	Off	On	On	On
288-28A	100010	Off	On	Off	On	Off	On
2A0-2A3	010100	Off	On	Off	Off	Off	On
328-32B	100101	Off	Off	On	On	On	On
330-333	100110	Off	Off	On	On	Off	On

**Address Selection Table**

The following illustration shows the correlation between the DIP-switch setting and the address bits used to determine the base address. In the example below, address 300 is selected as the base address. Address 300 in binary is XXX 100000 XXX where X = a non-selectable address bit and address bit A9 is always a 1.

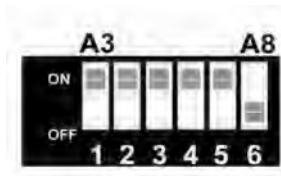

*DIP - Switch Illustration*



Setting the switch 'On' or 'Closed' corresponds to a '0' in the address, while leaving it 'Off' or 'Open' corresponds to a '1'.

## Options Header

P1	Function	P2	Function	P3	Function
1	Switch 1B	1	Common 1	1	Switch 1A
2	Switch 2B	2	Common 1	2	Switch 2A
3	Switch 3B	3	Common 1	3	Switch 3A
4	Switch 4B	4	Common 1	4	Switch 4A
5	Switch 5B	5	Common 1	5	Switch 5A
6	Switch 6B	6	Common 1	6	Switch 6A
7	Switch 7B	7	Common 1	7	Switch 7A
8	Switch 8B	8	Common 1	8	Switch 8A
9	Switch 9B	9	Common 2	9	Switch 9A
10	Switch 10B	10	Common 2	10	Switch 10A
11	Switch 11B	11	Common 2	11	Switch 11A
12	Switch 12B	12	Common 2	12	Switch 12A
13	Switch 13B	13	Common 2	13	Switch 13A
14	Switch 14B	14	Common 2	14	Switch 14A
15	Switch 15B	15	Common 2	15	Switch 15A
16	Switch 16B	16	Common 2	16	Switch 16A
17	Switch 17B	17	Common 3	17	Switch 17A
18	Switch 18B	18	Common 3	18	Switch 18A
19	Switch 19B	19	Common 3	19	Switch 19A
20	Switch 20B	20	Common 3	20	Switch 20A
21	Switch 21B	21	Common 3	21	Switch 21A
22	Switch 22B	22	Common 3	22	Switch 22A
23	Switch 23B	23	Common 3	23	Switch 23A
24	Switch 24B	24	Common 3	24	Switch 24A
25	Switch 25B	25	Common 4	25	Switch 25A
26	Switch 26B	26	Common 4	26	Switch 26A
27	Switch 27B	27	Common 4	27	Switch 27A
28	Switch 28B	28	Common 4	28	Switch 28A
29	Switch 29B	29	Common 4	29	Switch 29A
30	Switch 30B	30	Common 4	30	Switch 30A
31	Switch 31B	31	Common 4	31	Switch 31A
32	Switch 32B	32	Common 4	32	Switch 32A
33	GND	33	Common 1	33	5V/12V
34	GND	34	Common 2	34	5V/12V
35	GND	35	Common 3	35	5V/12V
36	GND	36	Common 4	36	5V/12V

## Optional Header, Continued

### Header JP1

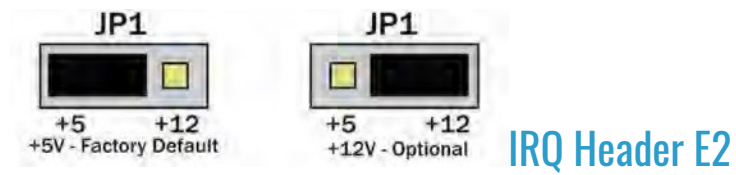

Header JP1 provides a means of connecting +5 VDC and +12 VDC from the PC bus to the Options Header. The center pin of this header is connected to P3 pins 3336.

### Optional Cable Connector P4

Discrete access to both sides of all relays is provided by attaching the optional cable (CA-108) to pin header P4 with the colored edge of the ribbon cable attached to pin one. Removing all the jumpers connecting row P1 to P2 places the A-side of each relay at the on-board DB-37 and the B-side at the optional cable's DB-37.



# Installation

## Software Installation

### Windows Installation



Do not install the Adapter in the machine until the software had been fully installed.



Only users running Windows 7 or newer should utilize these instructions for accessing and installing the appropriate driver via Sealevel's website. If you are utilizing an operating system prior to Windows 7, please contact Sealevel by calling 864.843.4343 or emailing [support@sealevel.com](mailto:support@sealevel.com) to receive access to the proper driver download and installation instructions.

---

1. Begin by locating, selecting, and installing the correct software from the [Sealevel software driver database](#).
2. Select the Part Number (**3098**) for your device from the listing.
3. Click the 'Download Now' button. The SealIO software is available for Windows and Linux.
4. The setup file will automatically detect the operating environment and install the proper components.
5. A screen may appear with the declaration: "The publisher cannot be determined due to the problems below: Authenticode signature not found." Please select the 'Yes' button and proceed with the installation. This declaration simply means that the Operating System is not aware of the driver being loaded. It will not cause any harm to your system.
6. During setup the user may specify installation directories and other preferred configurations. This program also adds entries to the system registry that are necessary for specifying the operating parameters for each driver. An uninstall option is also included to remove all registry/INI file entries from the system.

To confirm that the SealIO driver has been successfully installed, click on the 'Start' button, and then select 'All Programs'. You should see the 'SealIO' program folder listed.

You are now ready to proceed with connecting the 3098 to your system. Refer to the Hardware Installation section for details.



**Windows NT Card Installation:** After accomplishing the above steps, bring up the Control Panel and double-click on the SealIO Devices icon. To install a new card, click "Add Port". Repeat this procedure for as many SealIO cards as you wish to install.

## Linux Installation



You MUST have “root” privileges to install the software and drivers.



The syntax is case sensitive.

SeaCOM for Linux can be downloaded here: <https://www.sealevel.com/support/software-seacom-linux/>. It includes the **README** and the **Serial-HOWTO** help files (located at seacom/dox/howto). This series of files both explains typical Linux serial implementations and informs the user about Linux syntax and preferred practices.



User can use a program such as 7-Zip to extract the tar.gz file.

In addition, the software selectable interface settings can be accessed by referencing **seacom/utilities/3098mode**.

To set up Linux to automatically load the driver; refer to a Linux manual concerning your specific distribution for help.

For additional software support, including QNX, please call Sealevel Systems’ Technical Support, (864) 843-4343. Our technical support is free and available from 8:00 AM - 5:00 PM Eastern Time, Monday through Friday. For email support contact: [support@sealevel.com](mailto:support@sealevel.com).

## Installation, Continued

### Hardware Installation

The adapter can be installed in any PC expansion slot.



Do not install the Adapter in the machine until the software has been fully installed.

- 1. Turn off PC power. Disconnect the power cord.**
2. Remove the PC case cover.
3. Locate an available PC slot and remove the blank metal slot cover.
4. Gently insert the REL-32 adapter into the slot. Make sure that the adapter is seated properly.
5. After the adapter has been installed, the cables should be routed thru the opening in the bracket. This bracket also features a strain relief function that should be used to prevent un-expected cable removal.
6. Replace the screw you removed for the blank and use it to secure the adapter into the slot. (This is required to ensure FCC Part 15 compliance.)
7. Replace the cover.
8. Connect the power cord

The REL-32 is now ready for use.

# Programming the REL-32

Sealevel's Seal/O software is provided to assist in the development of reliable applications for the Sealevel Systems family of digital I/O adapters. The software also includes driver functions for use in accessing the I/O as well as helpful samples and utilities.

## Programming for Windows

The Seal/O API (Application Programmer Interface) provides a variety of useful high-level function calls implemented in a Windows dynamic link library (DLL). The API is defined in the help file (Start/Programs/SealO/SealO Help) under "Application Programmers Interface". This help file also includes detailed information dealing with installation / removal of the software and information about latency, logic states, and device configuration.

For C language programmers we recommend using the API to access the REL-32. If you are programming in Visual Basic, using the ActiveX control included with Seal/O is advised.

## Samples and Utilities

A variety of sample programs and utilities (both executable and source code) are included with Seal/O. Further documentation on these samples can be found by selecting "Start/Programs/Seal/O/Sample Application Description".

## Programming for Linux

Seal/O for Linux consists of two major parts: a kernel module and a library. The kernel module is a simple IO pass-through device, allowing the library to handle the more sophisticated functions provided to Seal/O users. It is provided in a 'tarball' format and can easily be compiled and included in the kernel build.

## Programming the REL-32, Continued

### Digital I/O Interface

The REL-32 provides four parallel input/output (I/O) ports. The ports are organized as ports 1, 2, 3, and 4.

### Output Ports (Reed Relay)

Reed relays provide very high quality, long life, low current, dry contact switch closures. Reed relays are not suited for high current applications and can be destroyed by inductive load switching. The relays are normally open, and close when energized.

### Connector and Jumper Pin Out

Each relay has two sides, an A-side and B-side. Each side is connected to two places: the cable, and the jumpers on the top of the board. The tables on the following pages provide the pin outs for the two DB-37 cable ends and the onboard jumpers.

# Programming the REL-32, Continued

## Jumper Setup Options

The common on each port may be tied to ground, 5, or 12 volts. Either side of each relay may then be tied to the common. The 3098 is shipped with all of the jumpers necessary for all possible configurations. The jumpers are parked on the B-side and are inactive until configured by the user. An example configuration is shown below:

- Port 4: The common is tied to ground (GND).  
The A-side of port-4 relay 3 (K27) is tied to the common.  
The B-side of port-4 relay 6 (K30) is tied to the common.
  
- Port 3: The common is tied to ground (GND).  
The A-side of port-3 relay 2 (K18) is tied to the common.  
The A-side of port-3 relay 5 (K21) is tied to the common.
  
- Port 2: The common is tied to 5 volts.  
The B-side of port-2 relay 4 (K12) is tied to the common.
  
- Port 1: The common is tied to 12 volts.  
The A-side of port-1 relay 1 (K1) is tied to the common.  
The A-side of port-1 relay 8 (K8) is tied to the common.

### Port 4



**GND A**  
**com5V B12V**  
**1 2 3 4 5 6 7 8**

### Port 3



**GND A**  
**COM5V B12V**  
**1 2 3 4 5 6 7 8**

### Port 2

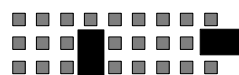

**GND A**  
**com5V B12V**  
**1 2 3 4 5 6 7 8**

### Port 1



**GND A**  
**com5V B12V**  
**1 2 3 4 5 6 7 8**

## Programming the REL-32, Continued

### Output Ports (Reed Relay) Pin Assignments

Via standard 6' cable, DB-78 Male to dual DB-37 Male connectors, Part Number CA172. The DB-37 connectors are labeled "Ports 1,2" and "Port 3,4".

Relay	Port 1				Relay	Port 2			
	Relay A Side		Relay B Side			Relay A Side		Relay B Side	
	Port 1 - A	Pin	Port 1 - B	Pin		Port 2 - A	Pin	Port 2 - B	Pin
K1	1	2	1	20	K9	1	10	1	28
K2	2	3	2	21	K10	2	11	2	29
K3	3	4	3	22	K11	3	12	3	30
K4	4	5	4	23	K12	4	13	4	31
K5	5	6	5	24	K13	5	14	5	32
K6	6	7	6	25	K14	6	15	6	33
K7	7	8	7	26	K15	7	16	7	34
K8	8	9	8	27	K16	8	17	8	35

Relay	Port 3				Relay	Port 4			
	Relay A Side		Relay B Side			Relay A Side		Relay B Side	
	Port 3 - A	Pin	Port 3 - B	Pin		Port 4 - A	Pin	Port 4 - B	Pin
K17	1	2	1	20	K25	1	10	1	28
K18	2	3	2	21	K26	2	11	2	29
K19	3	4	3	22	K27	3	12	3	30
K20	4	5	4	23	K28	4	13	4	31
K21	5	6	5	24	K29	5	14	5	32
K22	6	7	6	25	K30	6	15	6	33
K23	7	8	7	26	K31	7	16	7	34
K24	8	9	8	27	K32	8	17	8	35

### Power and Ground Pin Assignments

Via standard 6' cable, DB-78 Male to dual DB-37 Male connectors, Part Number CA172.

Ground	18, 36, 37
+ 5 Volts	19
+ 12 Volts	1

## Programming the REL-32, Continued

### Optional DB-37 Female Pin Assignment

In order to maintain compatibility with the existing ISA interface adapter (Sealevel Item# 3098), an optional 6' cable is offered with DB-78 Male to dual DB-37 Female connectors, Part Number CA173. The DB-37 connectors are labeled "Side A" and "Side B".

Side A			Side B		
Pin	Function	Jumper	Pin	Function	Jumper
1	Ground	N/A	1	Ground	N/A
2	Relay 2A	PORT 1-A2	2	Relay 2B	PORT 1-B2
3	Relay 4A	PORT 1-A4	3	Relay 4B	PORT 1-B4
4	Relay 6A	PORT 1-A6	4	Relay 6B	PORT 1-B6
5	Relay 8A	PORT 1-A8	5	Relay 8B	PORT 1-B8
6	Relay 10A	PORT 2-A2	6	Relay 10B	PORT 2-B2
7	Relay 12A	PORT 2-A4	7	Relay 12B	PORT 2-B4
8	Relay 14A	PORT 2-A6	8	Relay 14B	PORT 2-B6
9	Relay 16A	PORT 2-A8	9	Relay 16B	PORT 2-B8
10	Relay 18A	PORT 3-A2	10	Relay 18B	PORT 3-B2
11	Relay 20A	PORT 3-A4	11	Relay 20B	PORT 3-B4
12	Relay 22A	PORT 3-A6	12	Relay 22B	PORT 3-B6
13	Relay 24A	PORT 3-A8	13	Relay 24B	PORT 3-B8
14	Relay 26A	PORT 4-A2	14	Relay 26B	PORT 4-B2
15	Relay 28A	PORT 4-A4	15	Relay 28B	PORT 4-B4
16	Relay 30A	PORT 4-A6	16	Relay 30B	PORT 4-B6
17	Relay 32A	PORT 4-A8	17	Relay 32B	PORT 4-B8
18	12 V	N/A	18	12 V	N/A
19	5 V	N/A	19	5 V	N/A
20	Relay 1A	PORT 1-A1	20	Relay 1B	PORT 1-B1
21	Relay 3A	PORT 1-A3	21	Relay 3B	PORT 1-B3
22	Relay 5A	PORT 1-A5	22	Relay 5B	PORT 1-B5
23	Relay 7A	PORT 1-A7	23	Relay 7B	PORT 1-B7
24	Relay 9A	PORT 2-A1	24	Relay 9B	PORT 2-B1
25	Relay 11A	PORT 2-A3	25	Relay 11B	PORT 2-B3
26	Relay 13A	PORT 2-A5	26	Relay 13B	PORT 2-B5
27	Relay 15A	PORT 2-A7	27	Relay 15B	PORT 2-B7
28	Relay 17A	PORT 3-A1	28	Relay 17B	PORT 3-B1
29	Relay 19A	PORT 3-A3	29	Relay 19B	PORT 3-B3



## Programming the REL-32, Continued

30	Relay 21A	PORT 3-A5	30	Relay 21B	PORT 3-B5
31	Relay 23A	PORT 3-A7	31	Relay 23B	PORT 3-B7
32	Relay 25A	PORT 4-A1	32	Relay 25B	PORT 4-B1
33	Relay 27A	PORT 4-A3	33	Relay 27B	PORT 4-B3
34	Relay 29A	PORT 4-A5	34	Relay 29B	PORT 4-B5
35	Relay 31A	PORT 4-A7	35	Relay 31B	PORT 4-B7
36	Ground	N/A	36	Ground	N/A
37	Ground	N/A	37	Ground	N/A

## DB-78 Female Pin Assignment

This table shows the pin assignments via the card edge connector.

Relay	Port 1				Relay	Port 2			
	Relay A Side		Relay B Side			Relay A Side		Relay B Side	
	Port 1 - A	Pin	Port 1 - B	Pin		Port 2 - A	Pin	Port 2 - B	Pin
K1	1	2	1	20	K9	1	10	1	28
K2	2	3	2	21	K10	2	11	2	29
K3	3	4	3	22	K11	3	12	3	30
K4	4	5	4	23	K12	4	13	4	31
K5	5	6	5	24	K13	5	14	5	32
K6	6	7	6	25	K14	6	15	6	33
K7	7	8	7	26	K15	7	16	7	34
K8	8	9	8	27	K16	8	17	8	35

Relay	Port 3				Relay	Port 4			
	Relay A Side		Relay B Side			Relay A Side		Relay B Side	
	Port 3 - A	Pin	Port 3 - B	Pin		Port 4 - A	Pin	Port 4 - B	Pin
K17	1	39	1	57	K25	1	47	1	65
K18	2	40	2	58	K26	2	48	2	66
K19	3	41	3	59	K27	3	49	3	67
K20	4	42	4	60	K28	4	50	4	68
K21	5	43	5	61	K29	5	51	5	69
K22	6	44	6	62	K30	6	52	6	70
K23	7	45	7	63	K31	7	53	7	71
K24	8	46	8	64	K32	8	54	8	72

## Programming the REL-32, Continued

### Power and Ground Pin Assignments

Via DB-78 Female card edge connector.

Ground	18, 36, 37, 55, 73, 74
+ 5 Volts	19, 56
+ 12 Volts	1, 38

### Direct Hardware Control

In systems where the user's program has direct access to the hardware (DOS) the table below gives the mapping and functions that the REL-32 provides.

Function Available	Port	Address Hex	Port Type
R/W	1	Base + 0	Relay 1 - Relay 8
R/W	2	Base + 1	Relay 9 - Relay 16
R/W	3	Base + 2	Relay 17 - Relay 24
R/W	4	Base + 3	Relay 25 - Relay 32

R/W = Read or Write

### Reading the Outputs

The relay ports return the ones complement of the value that is currently being used to drive the relays. When using the API the value is returned not the complement of the value.

### Writing the Outputs

The relays on a standard 3098 are normally open. To close a relay a one must be written to the appropriate bit.

### Register Description

Address	Mode	D7	D6	D5	D4	D3	D2	D1	D0
Base+0	R/W	P1D7	P1D6	P1D5	P1D4	P1D3	P1D2	P1D1	P1D0
Base+1	R/W	P2D7	P2D6	P2D5	P2D4	P2D3	P2D2	P2D1	P2D0
Base+2	R/W	P3D7	P3D6	P3D5	P3D4	P3D3	P3D2	P3D1	P3D0
Base+3	R/W	P4D7	P4D6	P4D5	P4D4	P4D3	P4D2	P4D1	P4D0

# Electrical Characteristics

## Features

- Selectable I/O port addressing from 200H – 3F8H
- 4 sets of SPST Reed relays with each set having 8 relays
- Highly reliable 10 VA DIP reed relays utilized
- Multiple adapters can reside in same computer
- All address, data and control signals are TTL compatible

# Specifications

## Output Relays

<b>Contact Max Power Rating</b>	10W		
<b>Contact Voltage Maximum</b>	100 VDC/VAC		
<b>Contact Current Maximum</b>	.5A AC/DC RMS		
<b>Contact Resistance, Initial</b>	.15 $\Omega$		
<b>Rated Life</b>	200 Million Closures (Low Load)	100 Million Closures (Maximum Load)	
<b>Speed</b>	Operate - .5mS	Release - .5mS	Bounce - .5 mS
<b>Maximum Operating Speed</b>	600 Hz		

## Environmental Specifications

Specification	Operating	Storage
<b>Temperature Range</b>	0° to 70° C	-50° to 105° C

## Manufacturing

All Sealevel Systems Printed Circuit boards are built to UL 94V0 rating and are 100% electrically tested. These printed circuit boards are solder mask over bare copper or solder mask over tin nickel.

## Power Requirements

<b>Supply Line</b>	+5 VDC	+12VDC
<b>Rating</b>	800 mA	50 mA

## Physical Dimensions

<b>Board length</b>	13.3 inches (33.9 cm)
<b>Board Height including Goldfingers</b>	4.2 inches (10.7 cm)

# Example Circuits

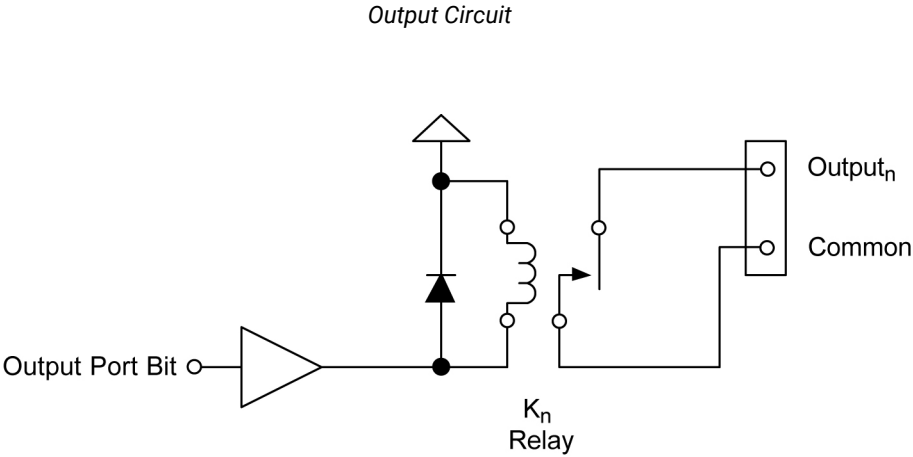

# Appendix A – Troubleshooting

Sealevel Software is supplied with the Sealevel Systems adapter and will be used in the troubleshooting procedures. By using this software and following these simple steps, most common problems can be eliminated without the need to call Technical Support.

1. **Install software first.** After installing the software then proceed to adding the hardware. This places the required installation files in the correct locations.
2. Read this manual thoroughly before attempting to install the adapter in your system.
3. Use Device Manager under Windows to verify proper installation.
4. Use the SealO Control Panel applet or the Device Manager's property page for card identification and configuration.
5. The following are known I/O conflicts:
  - The 278 and 378 settings may conflict with your printer I/O adapter.
    - a. 3B0 cannot be used if a Monochrome adapter is installed.
    - b. 3F8-3FF is typically reserved for COM1:
    - c. 2F8-2FF is typically reserved for COM2:
    - d. 3E8-3EF is typically reserved for COM3:
    - e. 2E8-2EF is typically reserved for COM4:

If these steps do not solve your problem, please call Sealevel Systems' Technical Support, (864) 843-4343. Our technical support is free and available from 8:00AM-5PM Eastern Time, Monday through Friday. For email support contact: [support@sealevel.com](mailto:support@sealevel.com).

# Appendix B – How To Get Assistance

Please refer to: Appendix A – Troubleshooting Guide prior to calling Technical Support.

Begin by reading through the Trouble Shooting Guide in Appendix A. If assistance is still needed, please see below.

When calling for technical assistance, please have your user manual and current adapter settings. If possible, please have the adapter installed in a computer ready to run diagnostics.

Sealevel Systems provides an FAQ section on its web site. Please refer to this to answer many common questions. This section can be found at <http://www.sealevel.com/faq.asp>.

Sealevel Systems maintains a web page on the Internet. Our home page address is [www.sealevel.com](http://www.sealevel.com). The latest software updates, and newest manuals are available via our web site.

Technical support is available Monday to Friday from 8:00 a.m. to 5:00 p.m. eastern time. Technical support can be reached at (864) 843-4343.

**RETURN AUTHORIZATION MUST BE OBTAINED FROM SEALEVEL SYSTEMS BEFORE RETURNED MERCHANDISE WILL BE ACCEPTED. AUTHORIZATION CAN BE OBTAINED BY CALLING SEALEVEL SYSTEMS AND REQUESTING A RETURN MERCHANDISE AUTHORIZATION (RMA) NUMBER.**

# Appendix C – Silk Screen – 3098 PCB

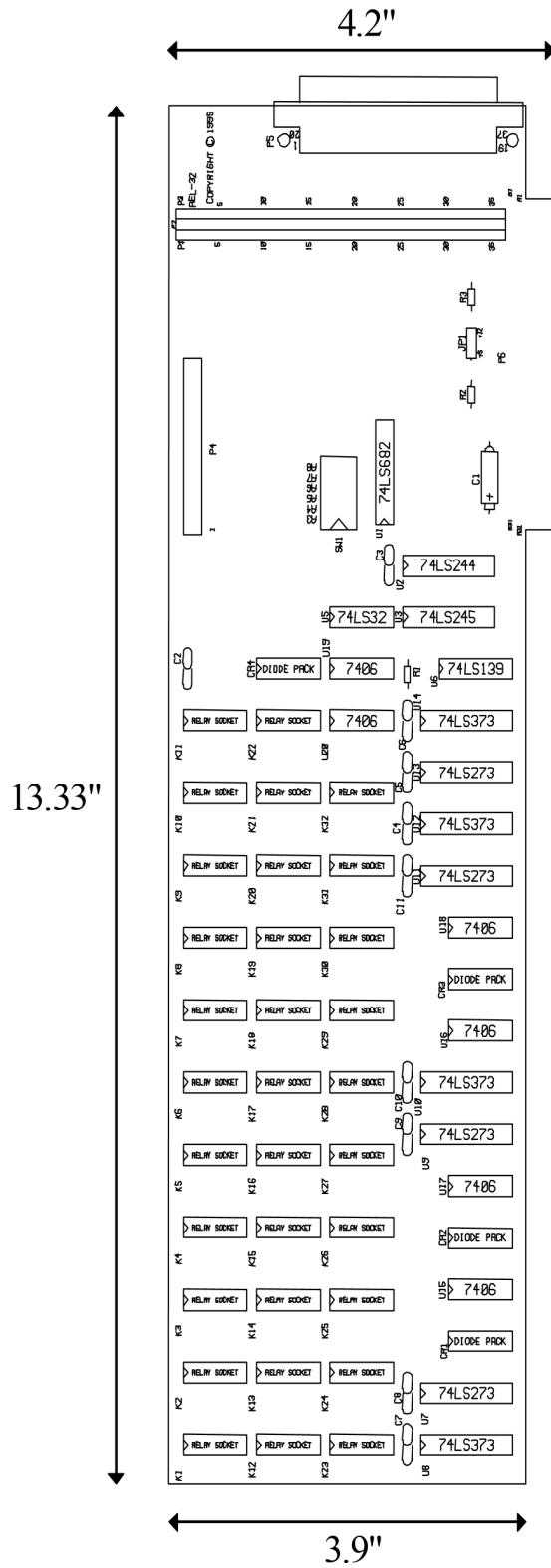



# Appendix D – Compliance Notices

## Federal Communications Commission (FCC) Statement



This equipment has been tested and found to comply with the limits for Class A digital device, pursuant to Part 15 of the FCC Rules. These limits are designed to provide reasonable protection against harmful interference when the equipment is operated in a commercial environment. This equipment generates, uses, and can radiate radio frequency energy and, if not installed and used in accordance with the instruction manual, may cause harmful interference to radio communications. Operation of this equipment in a residential area is likely to cause harmful interference in such case the user will be required to correct the interference at the user's expense.

## EMC Directive Statement



Products bearing the CE Label fulfill the requirements of the EMC directive (89/336/EEC) and of the low-voltage directive (73/23/EEC) issued by the European Commission. To obey these directives, the following European standards must be met:

- **EN55022 Class A** - "Limits and methods of measurement of radio interference characteristics of information technology equipment"
- **EN55024** – "Information technology equipment Immunity characteristics Limits and methods of measurement".



This is a Class A Product. In a domestic environment, this product may cause radio interference in which case the user may be required to take adequate measures to prevent or correct the interference.



Always use cabling provided with this product if possible. If no cable is provided or if an alternate cable is required, use high quality shielded cabling to maintain compliance with FCC/EMC directives.

# Warranty

Sealevel's commitment to providing the best I/O solutions is reflected in the Lifetime Warranty that is standard on all Sealevel manufactured I/O products. We are able to offer this warranty due to our control of manufacturing quality and the historically high reliability of our products in the field. Sealevel products are designed and manufactured at its Liberty, South Carolina facility, allowing direct control over product development, production, burn-in and testing. Sealevel achieved ISO-9001:2015 certification in 2018.

## Warranty Policy

Sealevel Systems, Inc. (hereafter "Sealevel") warrants that the Product shall conform to and perform in accordance with published technical specifications and shall be free of defects in materials and workmanship for the warranty period. In the event of failure, Sealevel will repair or replace the product at Sealevel's sole discretion. Failures resulting from misapplication or misuse of the Product, failure to adhere to any specifications or instructions, or failure resulting from neglect, abuse, accidents, or acts of nature are not covered under this warranty.

Warranty service may be obtained by delivering the Product to Sealevel and providing proof of purchase. Customer agrees to ensure the Product or assume the risk of loss or damage in transit, to prepay shipping charges to Sealevel, and to use the original shipping container or equivalent. Warranty is valid only for original purchaser and is not transferable.

This warranty applies to Sealevel manufactured Product. Product purchased through Sealevel but manufactured by a third party will retain the original manufacturer's warranty.

## Non-Warranty Repair/Retest

Products returned due to damage or misuse and Products retested with no problem found are subject to repair/retest charges. A purchase order or credit card number and authorization must be provided in order to obtain an RMA (Return Merchandise Authorization) number prior to returning Product.

## How to obtain an RMA (Return Merchandise Authorization)

If you need to return a product for warranty or non-warranty repair, you must first obtain an RMA number. Please contact Sealevel Systems, Inc. Technical Support for assistance:

Available	Monday – Friday, 8:00AM to 5:00PM EST
Phone	864-843-4343
Email	<a href="mailto:support@sealevel.com">support@sealevel.com</a>

## Trademarks

Sealevel Systems, Incorporated acknowledges that all trademarks referenced in this manual are the service mark, trademark, or registered trademark of the respective company.