

Dear Customer

Thank you for your order. We hope that you have received your furniture in the pristine condition that we sent it out in.

In the unfortunate event that your order was mishandled during transit, please contact us to let us know the extent of the damages so we can resolve for you as soon as possible.

If replacement parts are required, please email us with images and the part number referenced in this manual and we will have a replacement sent out right away.

We can be reached by the following email: cs@egtrading.co.uk.

Please include the full name and postcode used to place the order in your email so we can locate your order in our systems.

Alternatively, we can be reached by phone (Mon – Fri) on: 0161 401 6140.

The Customer Satisfaction Team

ASSEMBLING INSTRUCTIONS







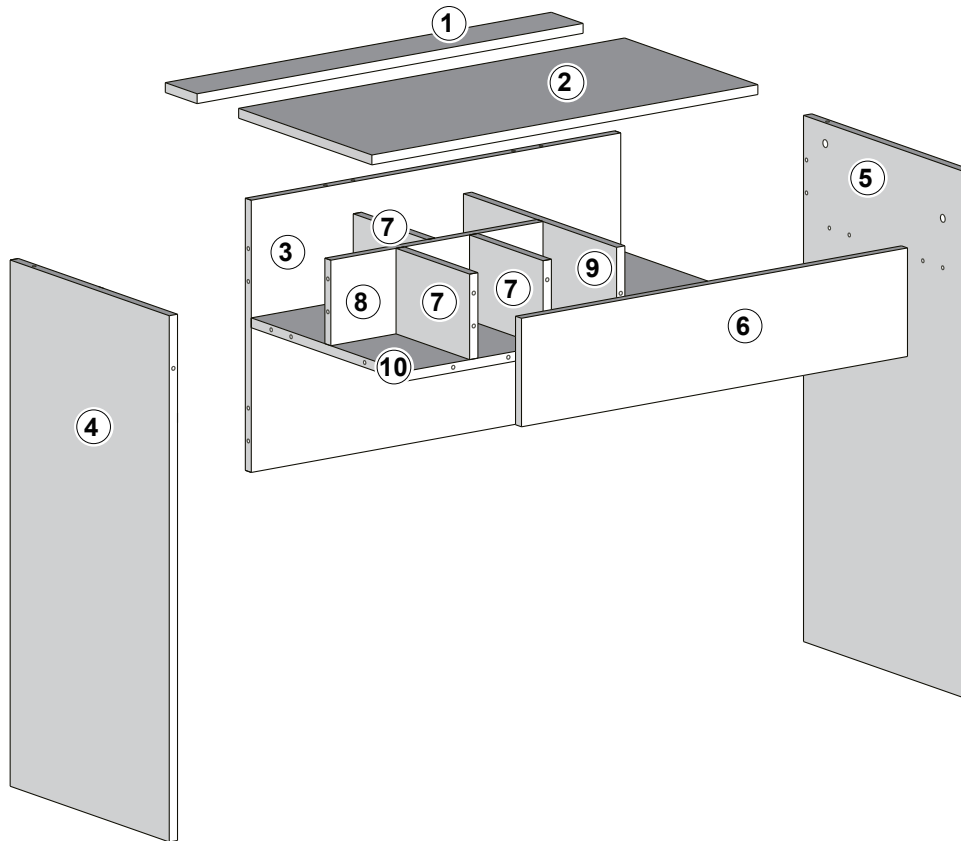

 easygift_products

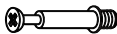
 easygiftproducts

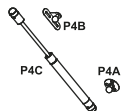
 easygiftproducts.co.uk





P1		17 PCS
P2		17 PCS
P3	 M4X35mm	7 PCS
P4		1 SET
P5		4 PCS
P6		2 PCS
P7	 M3.5X14mm	13 PCS
P8	 M5.8x30mm	16 PCS
P9	 M5x30mm	16 PCS

1

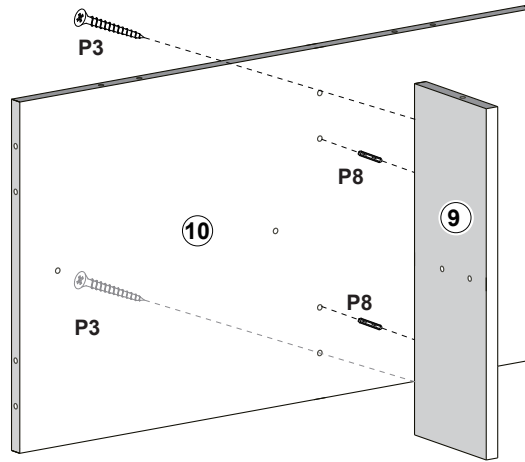

2

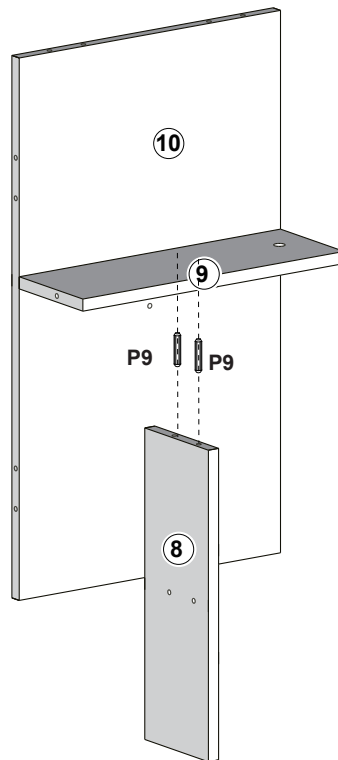

3

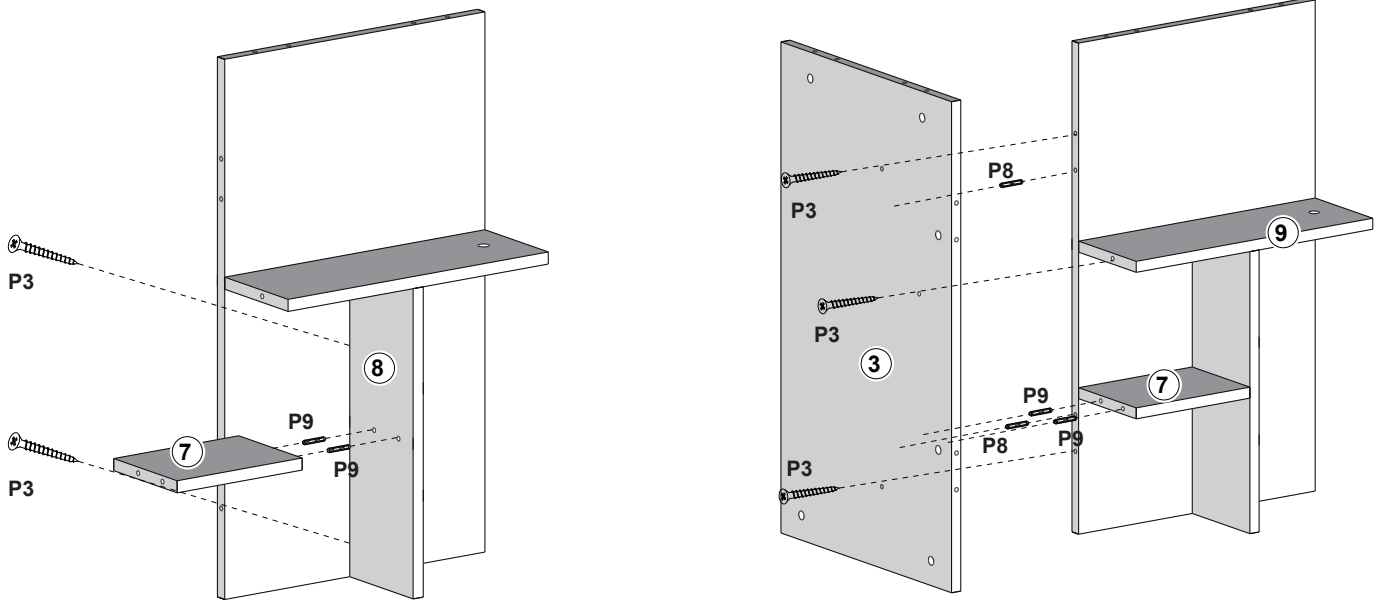

4

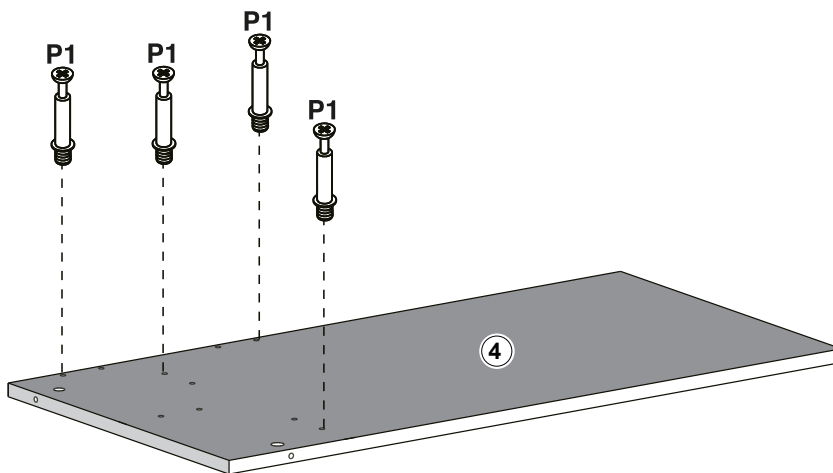

5

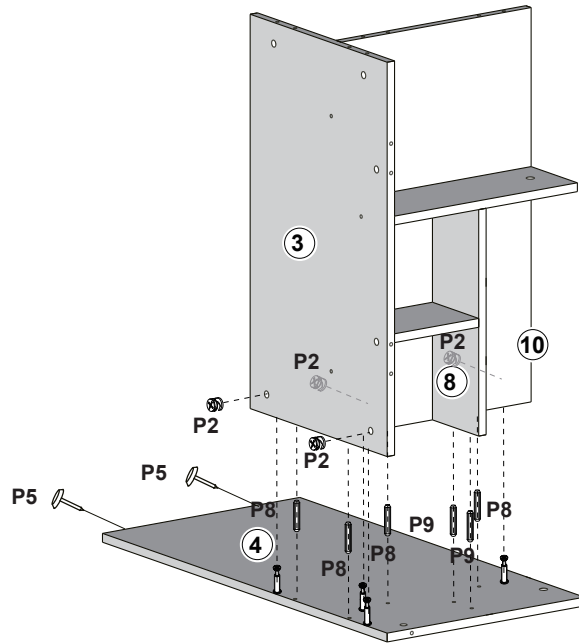

6

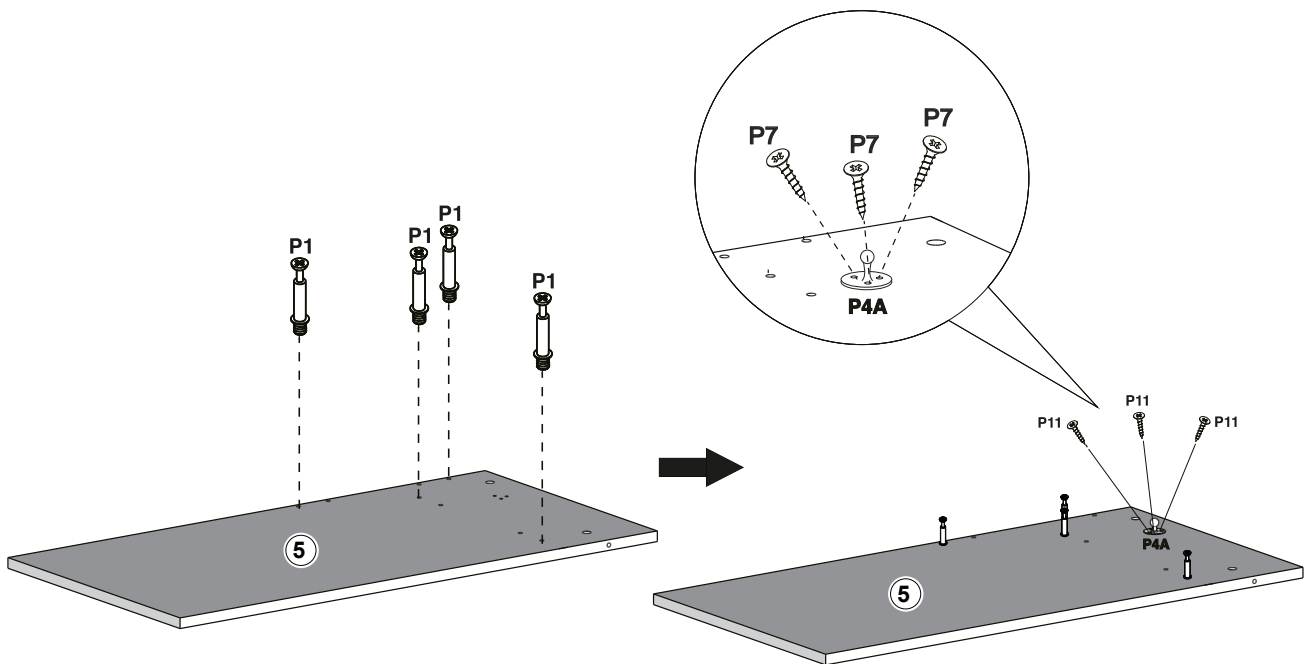

7

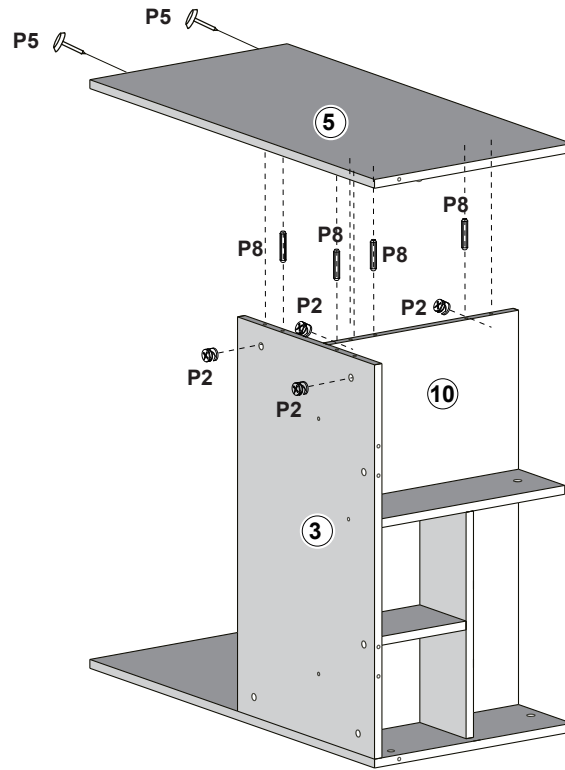

8

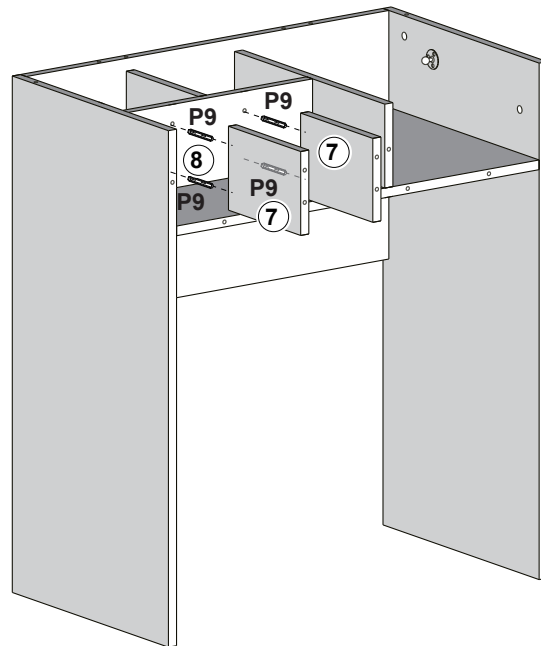

9

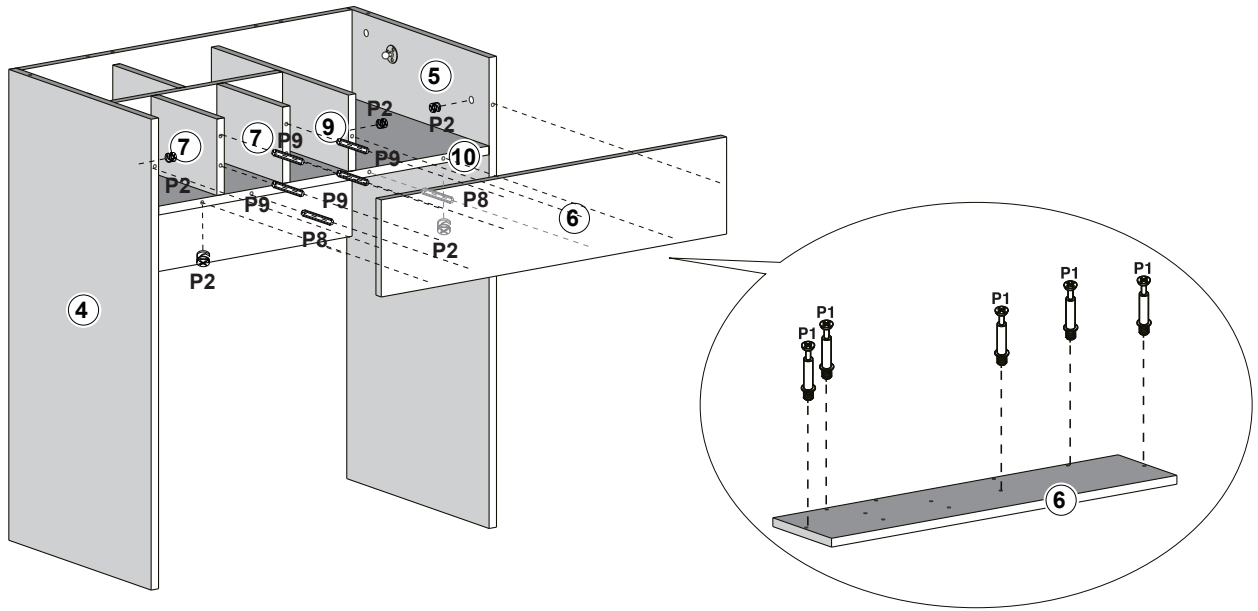

10

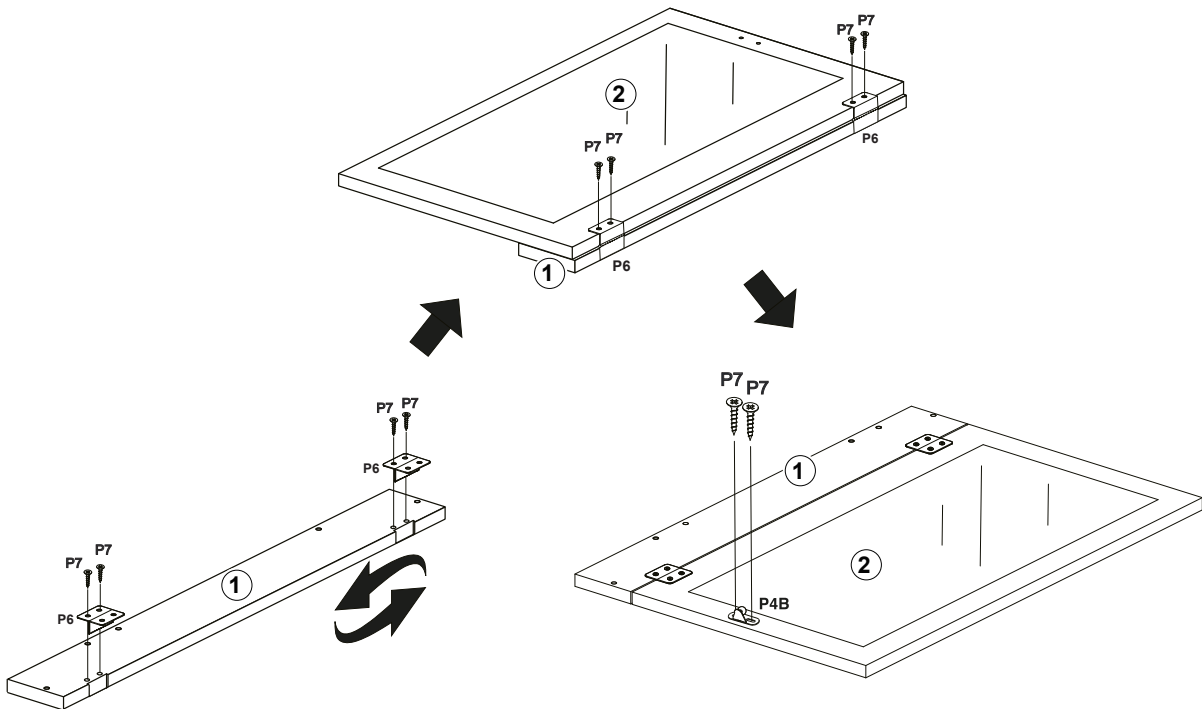

11

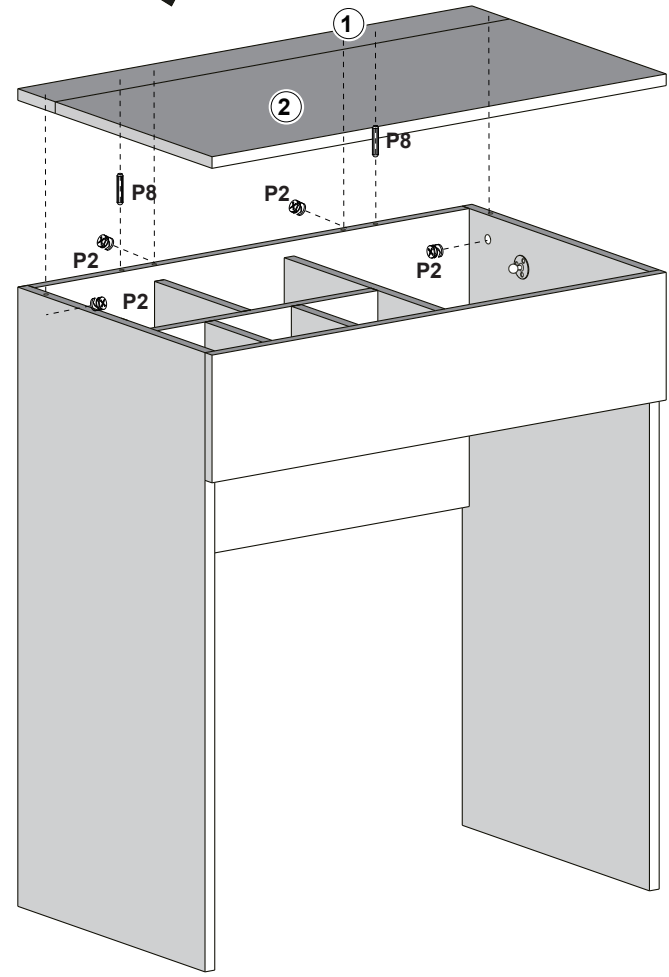
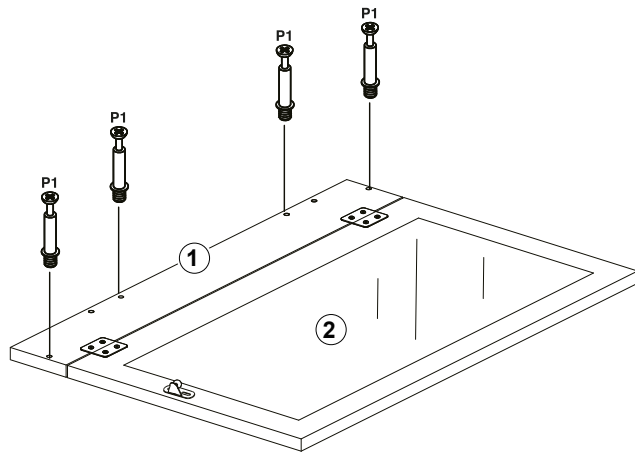

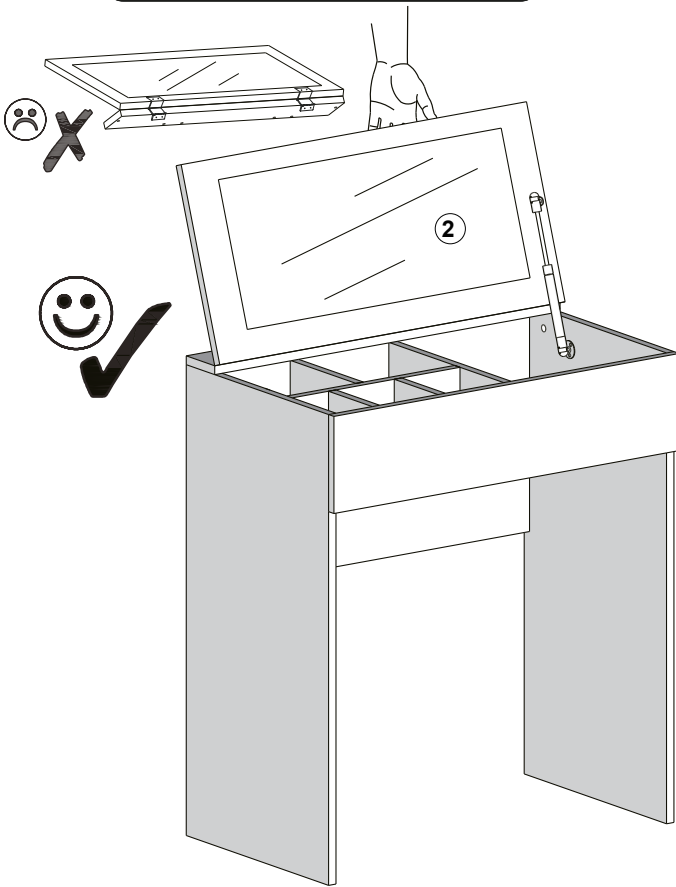
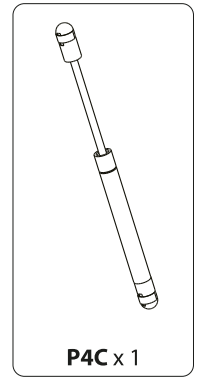
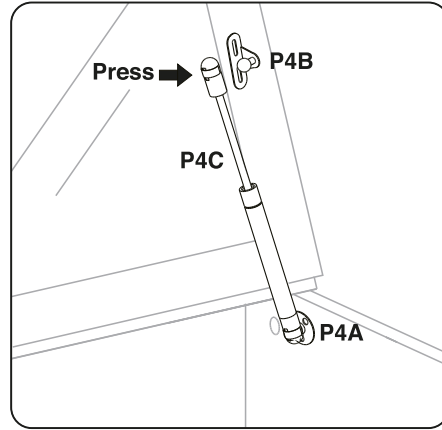
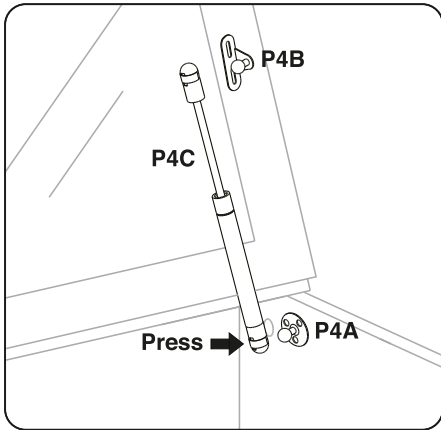

How to take out the Pneumatic Rod?

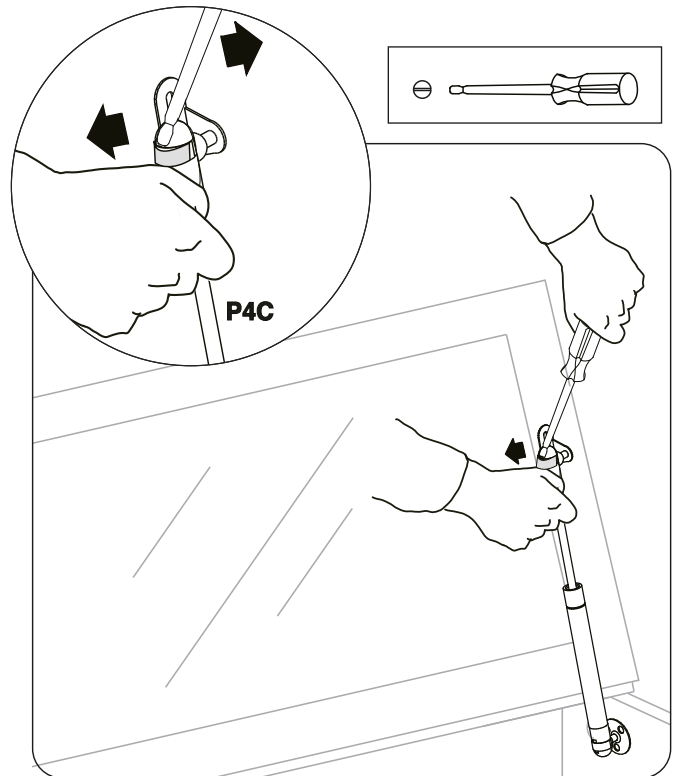

13 How to adjust the mirror angle?

Option 1

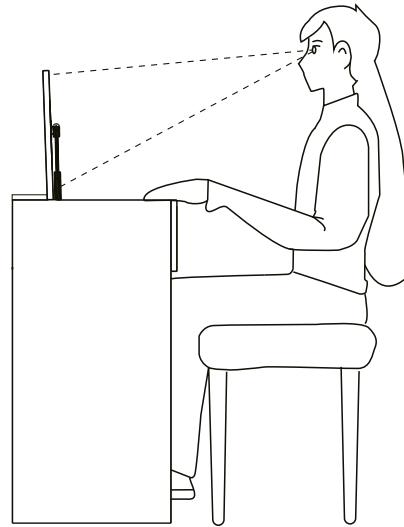
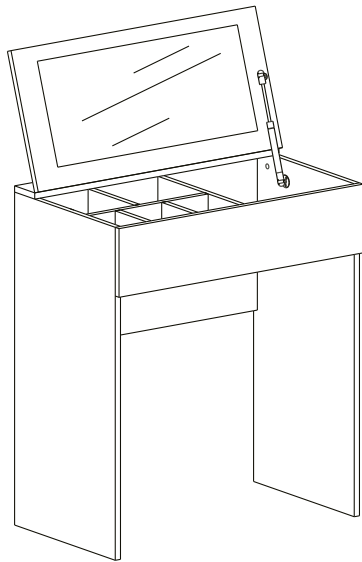
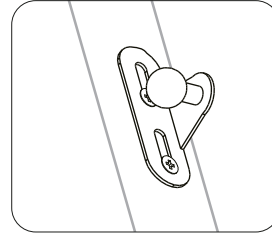
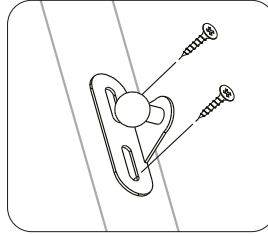

Option 2

