

# PH10 PLUS installation and user's guide

[www.renishaw.com](http://www.renishaw.com)

## PH10 PLUS installation and user's guide

Documentation part number: H-1000-7592-03-B



## PH10 PLUS installation and user's guide

www.renishaw.com

### General information

© 2013 - 2017 Renishaw plc. All rights reserved.

This document may not be copied or reproduced in whole or in part, or transferred to any other media or language, by any means, without the prior written permission of Renishaw.

The publication of material within this document does not imply freedom from the patent rights of Renishaw plc.

#### Disclaimer

RENISHAW HAS MADE CONSIDERABLE EFFORTS TO ENSURE THE CONTENT OF THIS DOCUMENT IS CORRECT AT THE DATE OF PUBLICATION BUT MAKES NO WARRANTIES OR REPRESENTATIONS REGARDING THE CONTENT. RENISHAW EXCLUDES LIABILITY, HOWSOEVER ARISING, FOR ANY INACCURACIES IN THIS DOCUMENT.

#### Trademarks

**RENISHAW®** and the probe emblem used in the **RENISHAW** logo are registered trademarks of Renishaw plc in the UK and other countries.

**apply innovation** is a trademark of Renishaw plc.

All brand names and product names used in this document are trade names, service marks, trademarks, or registered trademarks of their respective owners.

Windows XP, Windows 2000, Vista, Windows 7 and Windows 10 are registered trade names of the Microsoft Corporation.

All trademarks and trade names are acknowledged.

#### WEEE



The use of this symbol on Renishaw products and/or accompanying documentation indicates that the product should not be mixed with the general household waste upon disposal. It is the responsibility of the end user to dispose of this product at a designated collection point for waste electrical and electronic equipment (WEEE) to enable reuse or recycling. Correct disposal of this product will help save valuable resources and prevent potential negative effects on the environment. For more information, please contact your local waste disposal service or Renishaw distributor.

#### Warranty

Renishaw plc warrants its equipment for a limited period (as set out in our Standard Terms and Conditions of Sale) provided that it is installed exactly as defined in associated Renishaw documentation.

Prior consent must be obtained from Renishaw if non-Renishaw equipment (e.g. interfaces and/or cabling) is to be used or substituted. Failure to comply with this will invalidate the Renishaw warranty.

Claims under warranty must be made from authorised service centres only, which may be advised by the supplier or distributor.

## PH10 PLUS installation and user's guide

[www.renishaw.com](http://www.renishaw.com)

### Care of equipment

Renishaw probes and associated systems are precision tools used for obtaining precise measurements and must therefore be treated with care.

### Changes to Renishaw products

Renishaw reserves the right to improve, change or modify its hardware or software without incurring any obligations to make changes to Renishaw equipment previously sold.

### Packaging

To aid end user recycling and disposal the materials used in the different components of the packaging are stated here:

Packaging component	Material	94/62/EC code	94/62/EC number
Outer box	Polypropylene	PP	5
Outer box	Corrugated fibreboard	PAP	20
Packing foam	Low density Polyethylene	LDPE	4
Packing foam	Polyurethane	PU	7
Bag	Low density Polyethylene	LDPE	4

## PH10 PLUS installation and user's guide

[www.renishaw.com](http://www.renishaw.com)

# EU declaration of conformity

Contact Renishaw plc or visit [www.renishaw.com/productcompliance](http://www.renishaw.com/productcompliance) for the full EU declaration.

## PH10 PLUS installation and user's guide

www.renishaw.com

### FCC (USA only)

#### Information to user (47CFR section 15.105)

This equipment has been tested and found to comply with the limits for a Class A digital device, pursuant to Part 15 of the FCC rules. These limits are designed to provide reasonable protection against harmful interference when the equipment is operated in a commercial environment. This equipment generates, uses, and can radiate radio frequency energy and, if not installed and used in accordance with the instruction manual, may cause harmful interference to radio communications. Operation of this equipment in a residential area is likely to cause harmful interference, in which case you will be required to correct the interference at your own expense.

#### Information to user (47CFR section 15.21)

The user is cautioned that any changes or modifications not expressly approved by Renishaw plc or authorised representative could void the user's authority to operate the equipment.

#### Equipment label (47CFR section 15.19)

This device complies with part 15 of the FCC Rules. Operation is subject to the following two conditions:

1. This device may not cause harmful interference.
2. This device must accept any interference received, including interference that may cause undesired operation.

## PH10 PLUS installation and user's guide

[www.renishaw.com](http://www.renishaw.com)

# TÜV

This equipment has been independently certified by TÜV Product Services in accordance with OSHA (US) and SCC (Canada) requirements to the standards UL61010-1 Second Edition and CAN/CSA-C22-2 No. 61010-1 Second Edition.

## PH10 PLUS installation and user's guide

www.renishaw.com

# International safety instructions

### EN - WARNING

Please turn to appendix 1 and read the safety instructions in your own language before unpacking and installing this product.

### BG - Внимание

Моля, обърнете на приложение 1 и прочетете инструкциите за безопасност на вашия собствен език, преди за разопаковате и монтирате този продукт.

### CS - UPOZORNĚNÍ

Před rozbalením a instalací tohoto výrobku čtěte bezpečnostní pokyny uvedené v Příloze 1.

### DA - SIKKEREDHED

Læs sikkerhedsinstrukserne i Appendix 1 FØR udpakning og installation af dette produkt!

### DE - SICHERHEITSANWEISUNGEN

Lesen Sie die Sicherheitsanweisungen in Ihrer Sprache im Anhang 1 vor dem Auspacken und Installieren des Produktes.

### EL - ΑΣΦΑΛΕΙΑ

Πρέπει τώρα να γυρίσετε στο Κεφάλαιο 1 και να διαβάσετε τις οδηγίες ασφαλείας στη δική σας γλώσσα προτού ανοίξετε αυτό το προϊόν για να το εγκαταστήσετε.

### ES - SEGURIDAD

Debe volver al Apéndice 1 y leer las instrucciones de seguridad en su propio idioma antes de abrir e instalar este producto.

### ET - HOIATUSED

Nüüd peate vaatama 1. lisa ja enne selle toote lahtipakkimist ja paigaldamist lugema läbi ohutusjuhendi oma keeles.

### FI - TURVALLISUUTTA

Ennen tämän tuotteen pakkauksen avaamista ja asentamista lue liitteessä 1 olevat omalla kielelläsi kirjoitetut turvaohjeet.

### FR - SECURITE

Vous devez à présent consulter l'annexe 1 et les instructions de sécurité dans votre propre langue avant de déballer et d'installer ce produit.

### GA - RABHADH

Téigh chuig agusín 1 agus déan na treoracha sábháilteachta a léamh i do theanga féin le do thoil sula ndéantar an táirge seo a dhíphacáil agus a shuiteáil.

### HU - FIGYELMEZTETÉS

Lapozzon a 1. függelékhez és olvassa el a biztonsági előírásokat az Ön saját nyelvén mielőtt kicsomagolná és beüzemelné a terméket.

## PH10 PLUS installation and user's guide

www.renishaw.com

### IT - SICUREZZA

Prima di aprire ed installare questo prodotto dovete leggere le istruzioni di sicurezza nella Vostra Lingua riportate nell'Appendice 1.

### LT - ĮSPĖJIMAI

Prieš išpakuojant ir įdiegiant produktą jums reikia grįžti prie 1 priedo ir perskaityti nurodymus dėl saugos savo kalba.

### LV - BRĪDINĀJUMS

Pirms šī izstrādājuma izsaiņošanas un uzstādīšanas jums jāiepazīstas ar 1. pielikuma drošības instrukcijām savā valodā.

### MT - TWISSIJET

Issa għandek tmur f'appendiċi 1 sabiex taqra l-istruzzjonijiet tas-sigurtà fil-lingwa tiegħek qabel ma tispakkja u tinstalla dan il-prodott.

### NL - VELIGHEID

Ga nu naar Appendix 1 en lees de veiligheidsinstructies, in uw eigen taal, voordat u dit product uitpakt en installeert.

### PL - BEZPIECZEŃSTWO

Przed rozpakowaniem i instalacją produktu należy przeczytać załącznik nr 1 i zapoznać się z zasadami bezpieczeństwa w języku użytkownika.

### PT - SEGURANÇA

Você deve retornar ao Apêndice 1 e ler as instruções de segurança em seu idioma antes de desembalar e instalar este produto.

### RO - ATENȚIE

Înainte de a desface ambalajul și a instala acest produs, vă rugăm să căutați Anexa 1 și să citiți cu atenție instrucțiunile de protecția muncii, în limba română.

### SK - VÝSTRAHY

Pred rozbalením a inštaláciou tohto produktu si musíte pozrieť prílohu 1 a prečítať bezpečnostné pokyny vo vašom jazyku.

### SL - OPOZORILA

Sedaj morate v prilogi 1 prebrati varnostne napotke v svojem jeziku, preden odpakirate in namestite produkt.

### SV - SÄKERHETSFÖRESKRIFTER

Du måste nu gå till bilaga 1 och läsa säkerhetsinstruktionerna på ditt eget språk innan du packar upp och installerar denna produkt.



## PH10 PLUS installation and user's guide

www.renishaw.com

### Warnings

Where this symbol  is displayed on the product the user must refer to the installation and user guide for information and safety advice.

Pinch hazards exist between moving parts and between moving and static parts. Do not hold the probe head during movements, or when manually changing a probe.

Beware of unexpected movement. The user should remain outside the full working envelope of probe head/extension/probe combinations.

In all applications involving the use of machine tools or CMMs, eye protection is recommended.

Replace blown fuses with new components of the same type. Refer to the safety information in the relevant product documentation.

For instructions regarding the safe cleaning of Renishaw products, refer to the maintenance information in the relevant product documentation.

Remove power before performing any maintenance operations.

Refer to the machine supplier's operating instructions.

It is the machine supplier's responsibility to ensure that the user is made aware of any hazards involved in operation, including those mentioned in Renishaw product documentation, and to ensure that adequate guards and safety interlocks are provided.

Under certain circumstances the probe signal may falsely indicate a probe-seated condition. Do not rely on probe signals to stop machine movement.

If the equipment is used in a manner not specified by the manufacturer, the protection provided by the equipment may be impaired.

The expected method of providing an emergency stop for Renishaw products is to remove power.

## PH10 PLUS installation and user's guide

www.renishaw.com

### References and associated documents

Title	Document number
<a href="#">User's guide: Touch-trigger probes</a>	H-1000-5021
<a href="#">User's guide: SP25M</a>	H-1000-5104
<a href="#">User's guide: HCU2</a>	H-1000-5631
<a href="#">User's guide: AM1</a>	H-1000-4010
<a href="#">Data sheet: AM2</a>	H-1000-2051
<a href="#">Technical specification: Styli and accessories</a>	H-1000-3200
<a href="#">Installation guide: PICS</a>	H-1000-5000
<a href="#">Installation and user's guide: PHC10-3 PLUS</a>	H-1000-0077

## PH10 PLUS installation and user's guide

[www.renishaw.com](http://www.renishaw.com)

### Introduction

This guide describes the installation and product usage of the PH10 PLUS series of motorised probe heads. This guide gives information on physical installation and system connections, as well as assistance in fault-finding during the installation of a system.

The components of the PH10 PLUS system are not compatible with PH9 and PH20 system components. No attempt should be made to connect the PH10 PLUS system components to a PH9 or PH20 system as this will result in damage to the product.

 **CAUTION:** PH10 PLUS must be used in conjunction with the Renishaw PHC10-3 PLUS when part of an OEM installation not using Renishaw UCC controllers.

This guide should be read in conjunction with the PHC10-3 PLUS installation guide (part number H-1000-0077) in order to fully understand the system's features, capabilities and operation.

## PH10 PLUS installation and user's guide

www.renishaw.com

### PH10 system description

Product	Description
PH10T PLUS	A shank-mounted head with two-wired probe capability and an M8 thread.
PH10M PLUS	A shank-mounted head with multiwired probe capability and a Renishaw autojoint.
PH10MQ PLUS	A quill-mounted head with multiwired probe capability and a Renishaw autojoint.
HCU2	A hand control unit for use with PH10 measurement systems.
PHC10-3 PLUS	A controller for use with PH10 measurement systems.

The PH10 PLUS range of motorised heads consists of three different models:

Each head in the PH10 PLUS range is a general purpose, versatile unit designed specifically for use on direct computer controlled (DCC) CMMs and incorporates the following features:

- 720 indexing positions
- 0.4 µm indexing repeatability
- 7.5° indexing steps in both axes
- 300 mm (maximum) extension bar capability \*

**i** \* **NOTE:** 450 mm is possible for PH10M PLUS / PH10MQ PLUS with special order carbon fibre extensions.

**⚠ WARNING:** The components of the PH10 PLUS system are not compatible with PH9 system components. No attempt should be made to connect PH10 PLUS system components to a PH9 system, as this will result in damage to the product.

# PH10 PLUS installation and user's guide

www.renishaw.com

## System interconnection diagrams

### PH10 PLUS system with standard two wired touch-trigger probes

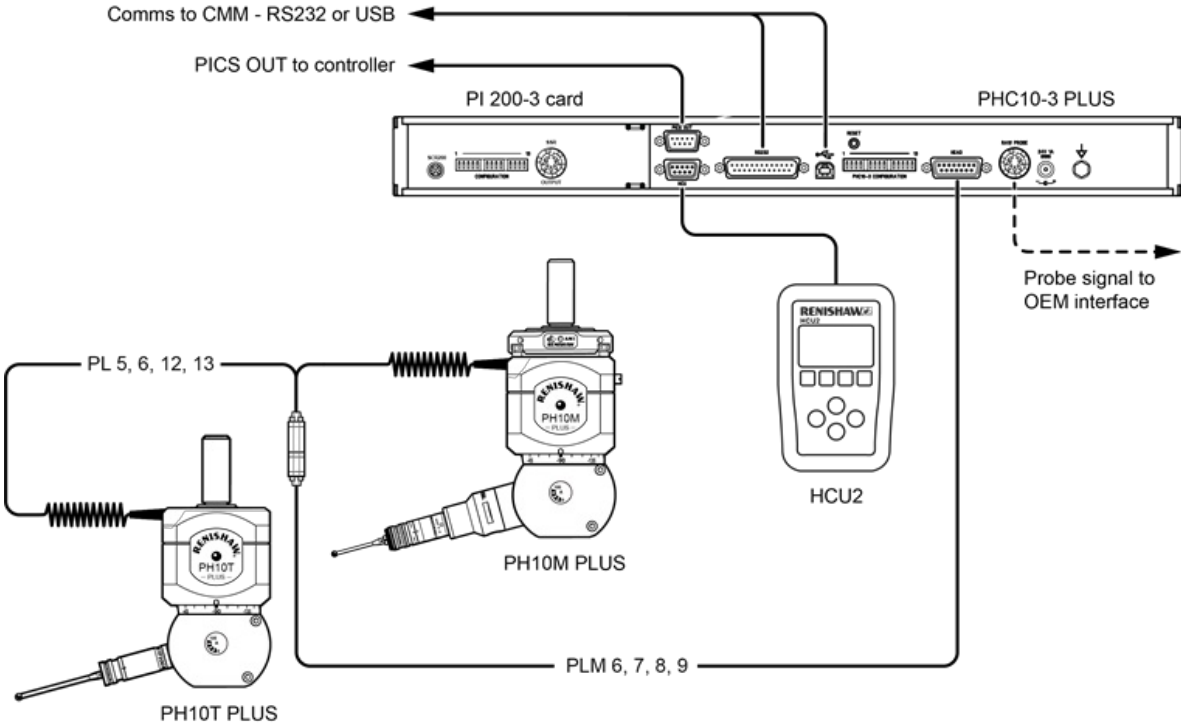

# PH10 PLUS installation and user's guide

www.renishaw.com

## PH10 PLUS system with standard two wire touch-trigger probe and autochange

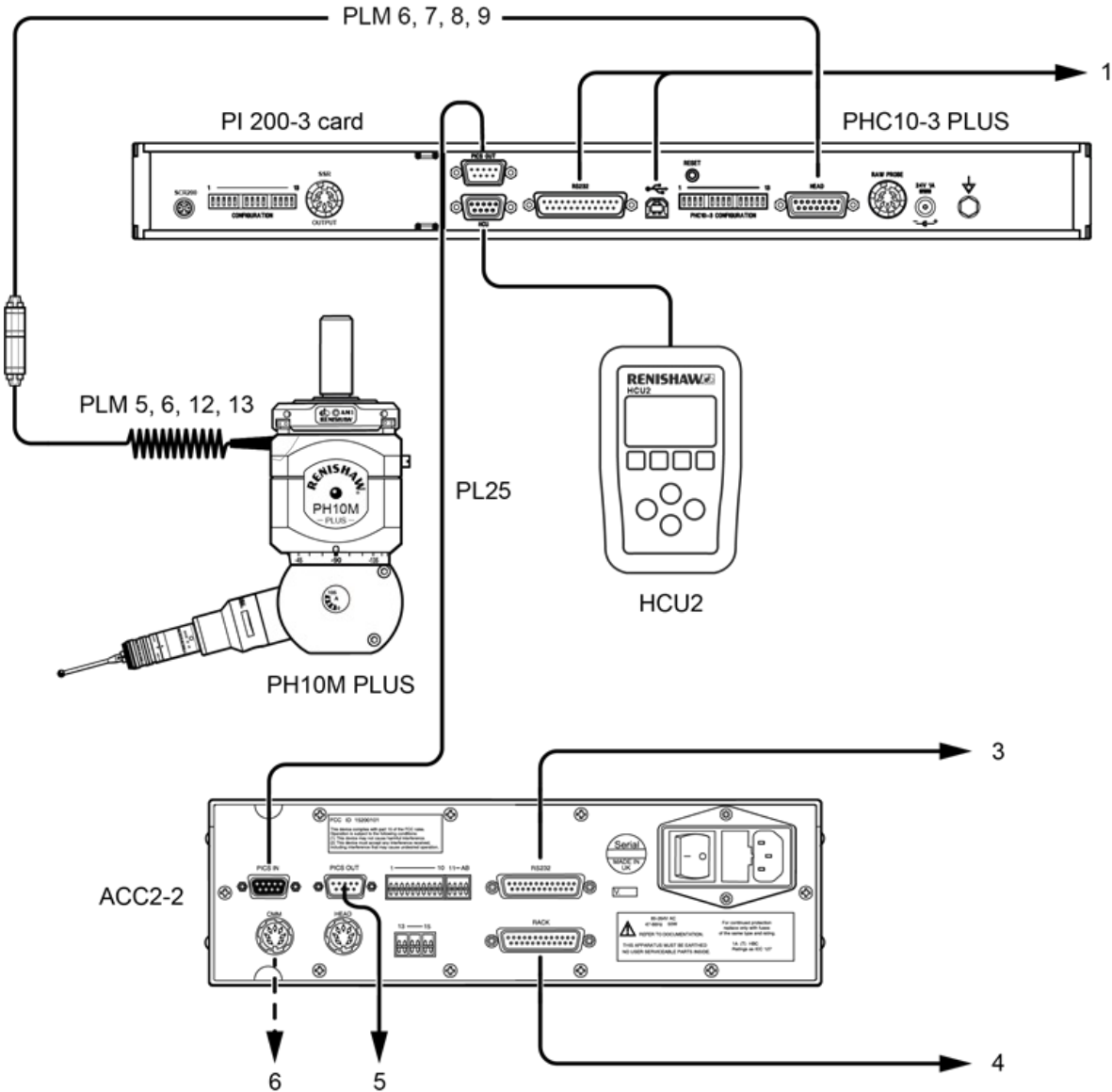

Key	Description
1	Communication connection to CMM controller RS232 or USB
3	Communication to CMM controller
4	Communication to autochange rack
5	PICS output to CMM
6	Probe output to CMM controller

# PH10 PLUS installation and user's guide

www.renishaw.com

## PH10 PLUS system with standard two wire touch-trigger probe, PI 200-3 and autochange

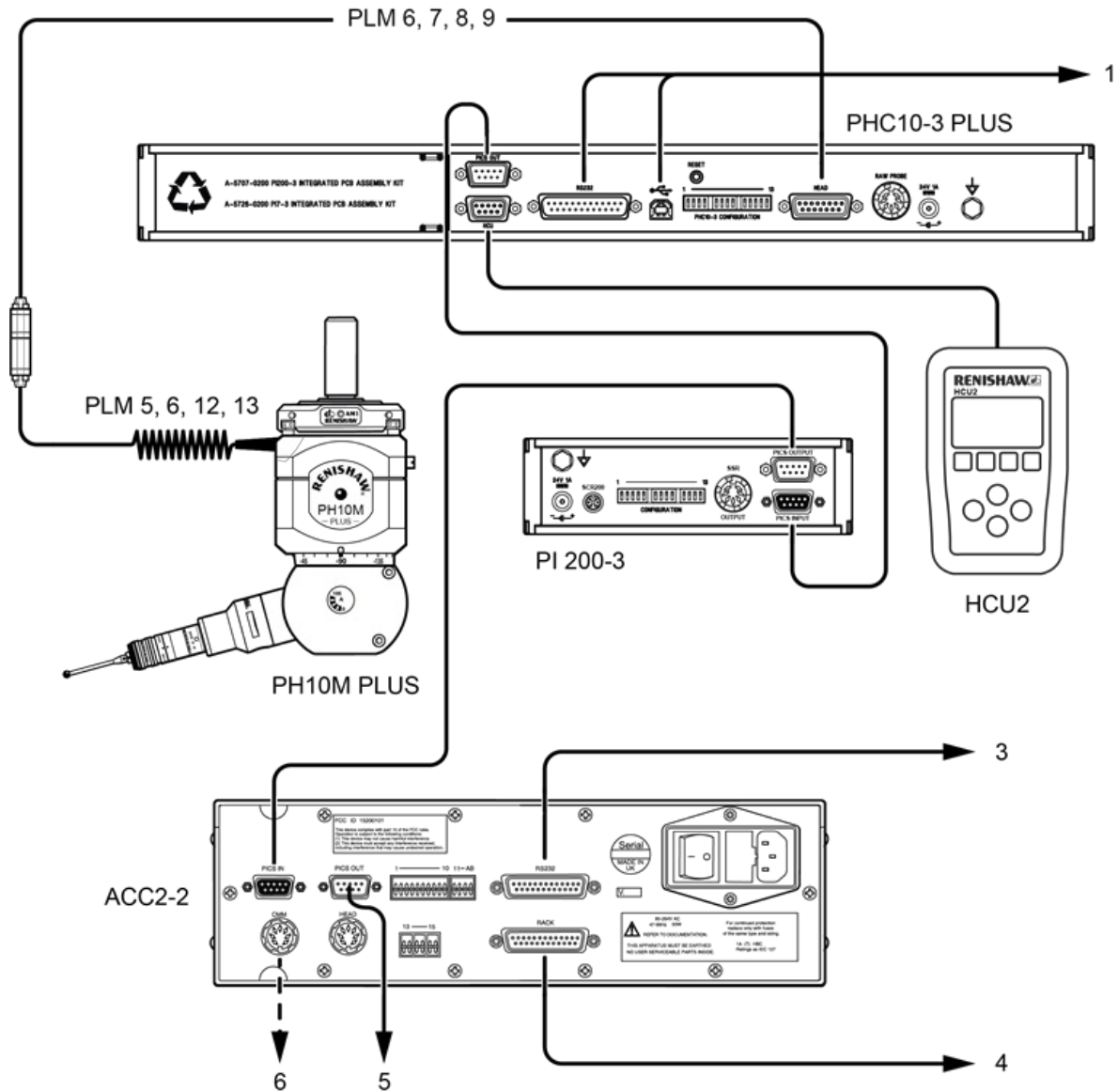

Key	Description
1	Communication connection to CMM controller - RS232 or USB
3	Communication to CMM controller
4	Communication to autochange rack
5	PICS output to CMM controller
6	Raw probe output to CMM controller

# PH10 PLUS installation and user's guide

www.renishaw.com

## PH10 PLUS system with multiwire scanning probes

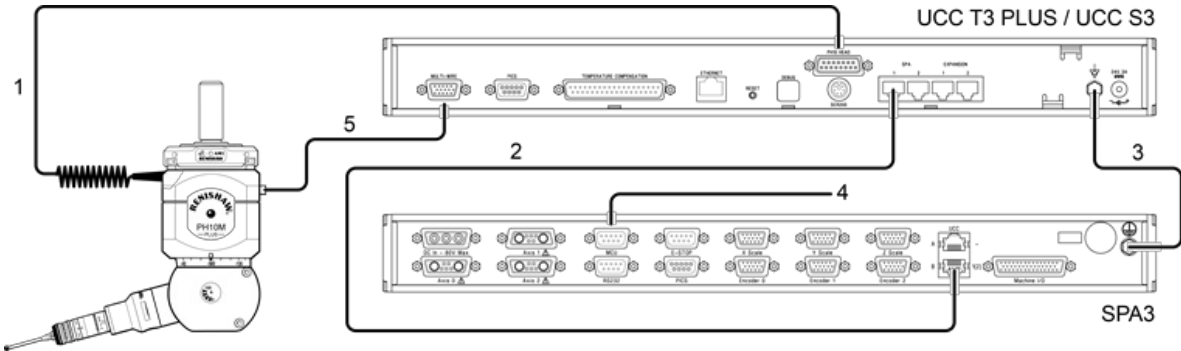

Key	Description	Key	Description
1	Head cable(s)	4	MCU connection
2	RJ45 cable (supplied)	5	Multiwire cable
3	16 / 0.2 mm earth connection		



## PH10 PLUS installation and user's guide

[www.renishaw.com](http://www.renishaw.com)

### Styli

Renishaw manufacture an extensive range of precision styli and stylus accessories. They are available in M2, M3, M4 and M5 thread sizes with steel, tungsten carbide, graphite fibre and ceramic stems. Each is fitted with a precision industrial synthetic ball (ruby, zirconia or silicon nitride) available in diameters from 0.3 mm (0.012 in) to 10 mm (0.4 in).

Special application styli including discs, cylinders, pointers, stars and large ceramic balls up to 30 mm (1.18 in) are available in M2 and M3 thread sizes.

For further information on the Renishaw stylus range, please refer to the stylus and accessories guide (part number H-1000-3200).

Renishaw also offer a custom design service if your requirements are not met by the standard range. Please contact your Renishaw supplier for details.

## PH10 PLUS installation and user's guide

www.renishaw.com

### Probe extension bars

Renishaw manufactures a comprehensive range of extension bars and adaptors to allow increased component penetration.

There are three types in the range:

- Autojoint to M8 bush (PAA series)
- Autojoint to autojoint (PEM series)
- M8 thread to M8 bush (PEL series)

#### Autojoint to M8 bush

These extension bars connect directly to the autojoint of the PH10M PLUS or PH10MQ PLUS head and terminate in an M8 bush. This permits the use of two-wire touch-trigger probes.

Extensions	Length	Material	Weight
PAA1	32 mm	Steel	57 g
PAA2	144 mm	Aluminium	85 g
PAA3	300 mm	Aluminium	144 g

The probe is fitted to the extension by hand and tightened by use of the S1 'C' spanner as shown.

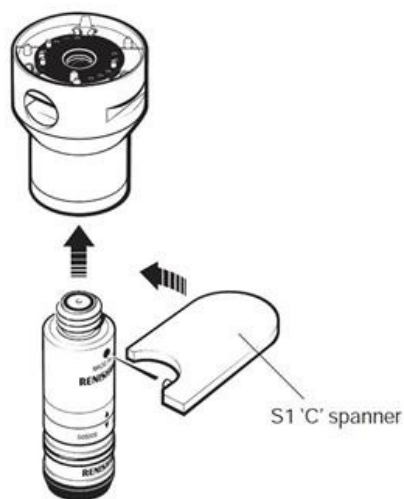

The S1 spanner is designed to fail before damage can occur to the mechanical joint between the two parts. Using the S1 spanner, fully hand-tighten the probe body into the M8 bush (0.3 Nm to 0.5 Nm).

## PH10 PLUS installation and user's guide

www.renishaw.com

### Autojoint to autojoint

These extension bars are compatible with the PH10M PLUS and PH10MQ PLUS heads. They allow direct connection to the head via the autojoint and terminate in an autojoint. This permits use of a multiwired probe.

Extensions	Length	Material	Weight
PEM25	25 mm	Aluminium	60 g
PEM1	50 mm	Aluminium	64 g
PEM2	100 mm	Aluminium	93 g
PEM3	200 mm	Aluminium	147 g

### M8 thread to M8 bush

These extension bars can be used directly with the PH10T PLUS head, and also with the PH10M PLUS and PH10MQ PLUS heads using the PAA1 adaptor.

Extensions	Length	Material	Weight
PEL1	50 mm	Aluminium	22 g
PEL2	100 mm	Aluminium	43 g
PEL3	200 mm	Aluminium	80 g
PEL4	300 mm	Aluminium	141 g

## PH10 PLUS installation and user's guide

www.renishaw.com

### PH10 compatible probes

#### M8 touch-trigger probes

This range of probes utilises the M8 bush for mounting to the head. These can be fitted directly onto the PH10T PLUS head, but when used with the PH10M PLUS or PH10MQ PLUS heads, one of the autojoint to M8 bush extension bars of the PAA1 adaptor must be used.

Probe	Diameter	Application	User's guide
TP2-5W	13 mm	Universal probe for DCC and manual CMMs.	H-1000-5021
TP6*	25 mm	Universal probe for DCC and manual CMMs.	H-1000-5008
TP20	13.2 mm	Universal probe for DCC and manual CMMs with module changing.	H-1000-5021
TP200	13.5 mm	Universal probe with strain gauge for DCC CMM - 100 mm max stylus length.	H-1000-5014

\* An autojoint version (TP6A) is also available

#### Multiwire (autojoint) probes

This range of probes is compatible with the PH10M PLUS and PH10MQ PLUS heads only and utilise the Renishaw multiwired autojoint connection to the head.

Probe	Diameter	Application	Weight	User's guide
SP25M	25 mm	High speed scanning probe.	65 g (body) 35 g (SM25-1) 40 g (SM25-2) 49 g (SM25-3) 71 g (SM25-4) 45 g (SM25-5) 40 g (TM25-20)	H-1000-5104
TP7M	25 mm	Universal probe with strain gauge for DCC CMMs.	85 g (without stylus)	H-1000-2010
SP600M*	50 mm	Analogue contact scanning probe.	216 g (without stylus)	H-1000-5175

Probes in this range require comprehensive integration with your CMM.

\* When using PH10MQ PLUS with SP600M, a PEM25 extension bar is required to achieve  $A = 97.5^\circ$  or  $A = 105^\circ$  in all B-axis positions.

## PH10 PLUS installation and user's guide

www.renishaw.com

# PH10 connection of probes and extensions

### PH10T PLUS M8 connection

PH10T PLUS is designed to carry Renishaw probes and extensions with an M8 screw thread. Probes and extensions are screwed into the probe head's bush and tightened with the appropriate spanner.

**CAUTION:** Never use anything other than the Renishaw spanner provided and do not apply excessive force.

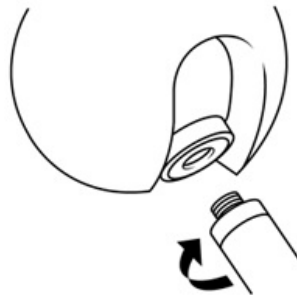

### PH10M PLUS and PH10MQ PLUS autojoint connection

PH10M PLUS and PH10MQ PLUS heads use a Renishaw autojoint which is a highly repeatable kinematic joint, one half is integral to the head. The other half forms part of the adaptor, extension bar or probe.

Locking and unlocking the autojoint is carried out either manually, using the autojoint key, or automatically using the Renishaw autochange rack systems (ACR1 or ACR3). In both cases, the connection's repeatability eliminates the need for probe requalification after exchange.

If an extension bar, adaptor or probe needs to be attached to the head manually, ensure that the location dots shown in the image below are aligned.

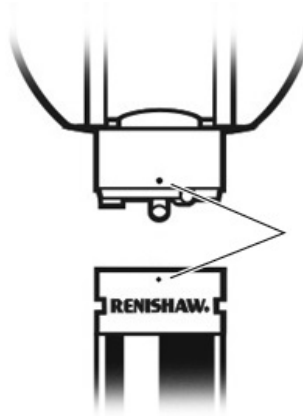

# PH10 PLUS installation and user's guide

www.renishaw.com

## System diagrams

### PH10T PLUS system diagram

The diagram below shows the range of extensions, probes and styli which can be used in conjunction with the PH10T head.

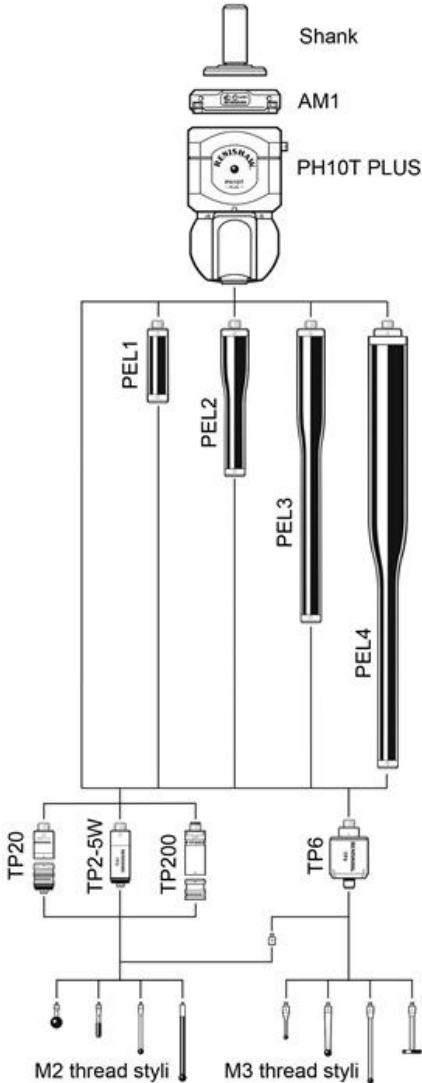

# PH10 PLUS installation and user's guide

www.renishaw.com

## PH10M PLUS and PH10MQ PLUS system diagrams

The diagram below shows the range of extensions, probes and styli which can be used in conjunction with the PH10M PLUS and PH10MQ PLUS heads.

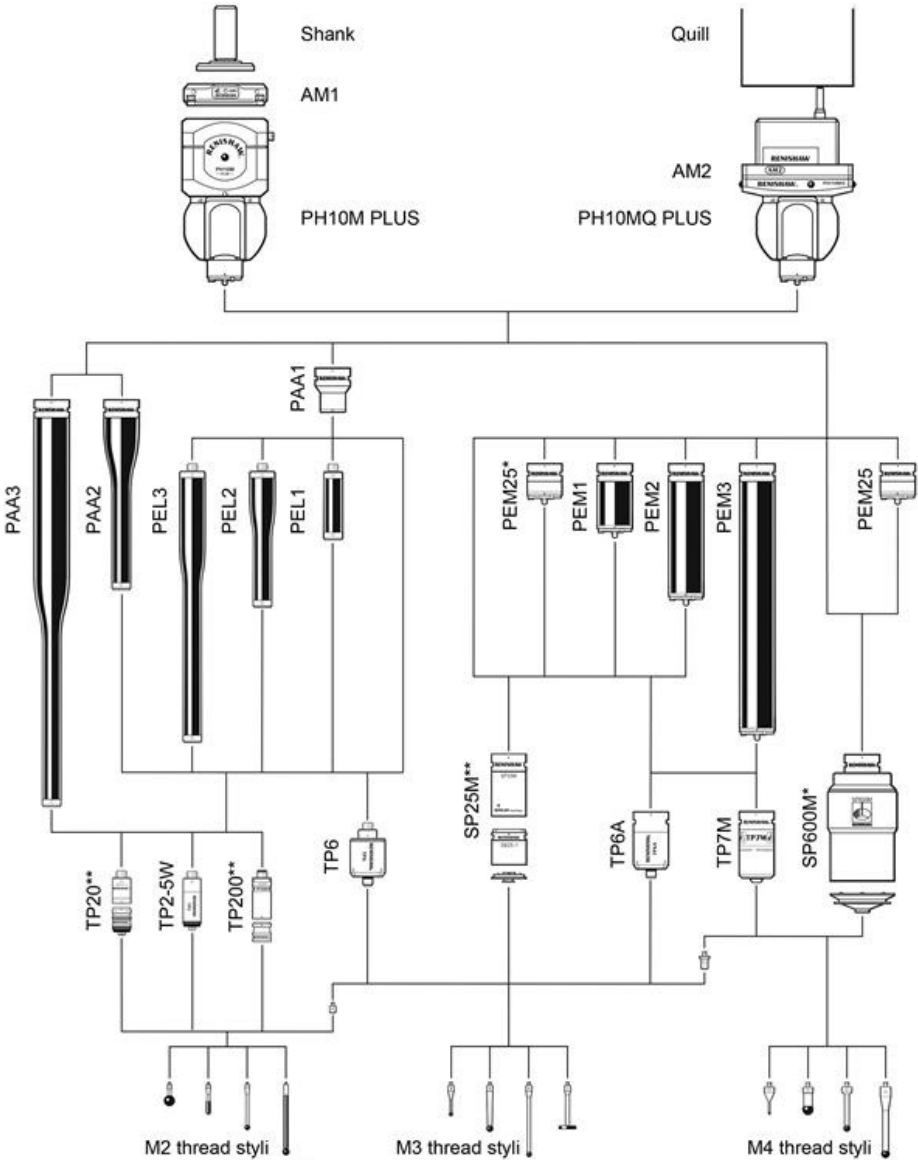

\* PH10MQ PLUS used with SP600M requires a PEM25 extension bar to achieve A = 97.5° or A = 105° in all B-axis positions.

\*\* Other modules versions are available for TP20, TP200 and SP25M.

## PH10 PLUS installation and user's guide

[www.renishaw.com](http://www.renishaw.com)

### HCU2 hand control unit

The HCU2 hand control unit is an optional control which enables the PH10 PLUS system to be used in manual mode or in a teach cycle. A LCD dot matrix display provides information on system status.

See the HCU2 user's guide (part number H-1000-5361) for further information on the features and operation of the unit, or contact your Renishaw representative for advice.





## PH10 PLUS installation and user's guide

www.renishaw.com

### PHC10-3 PLUS probe head controller

PH10 PLUS heads must be used in conjunction with either the PHC10-3 PLUS controller or the UCC (universal CMM controller).

PHC10-3 PLUS uses an external power supply for the head, manages all head functions and communicates via a suitable interface with the CMM computer.

A separate probe interface is required for probe signal conditioning when using the PHC10-3 PLUS. If using the UCC, the PHC1050 daughtercard takes its power from the host unit.



#### Powering PHC10-3 PLUS

PHC10-3 PLUS is to be used with the provided PSU - (Emerson DP4024N3M AC power adaptor) [www.emerson.com](http://www.emerson.com). This is a 24 Vdc 49 W supply and is connected to the PHC10-3 PLUS via Ø5.5 mm dc jack plug.

PHC10-3 PLUS does not require a protective earth, however an equipotential bonding point is provided on the rear panel for connection to the rest of the installation.

- PHC10-3 PLUS is rated to operate at +24 Vdc 1A max input current

If an internal interface is fitted with the PHC10-3 PLUS it will obtain its power internally from the PHC10-3 PLUS controller.

## PH10 PLUS installation and user's guide

www.renishaw.com

### PHC10-3 PLUS rear panel layout

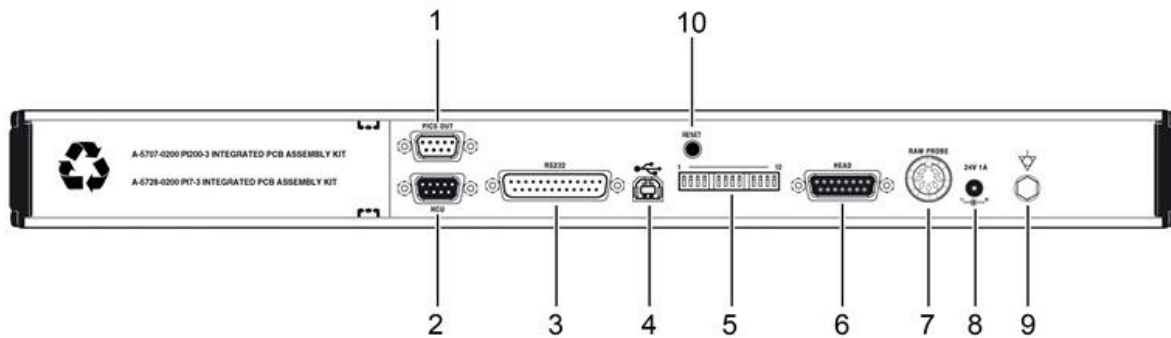

Key	Description
1	9-way D-type plug for PICS output.
2	9-way D-type connector to HCU2.
3	25-way D-type plug RS232 communications connector to CMM computer.
4	USB type 'B' socket.
5	PHC10-3 configuration switches.
6	15-way D-type connector to probe head.
7	7-pin DIN raw probe connector to probe interface or multiwire input for internal interfaces.
8	DC power jack.
9	Equipment bond point.
10	Reset button.

Refer to the PHC10-3 PLUS installation guide (part number H-1000-0077) for further detail.

## PH10 PLUS installation and user's guide

www.renishaw.com

### PHC10-3 PLUS LED description

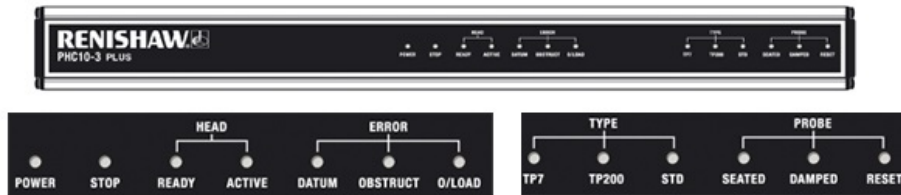

Name	Colour	Function
POWER	Green	Power on when lit
STOP	Red	PHC10-3 PLUS asserting PICS STOP when lit PI 200-3 asserting PICS STOP when flashing
HEAD READY	Green	Head ready for use when lit
HEAD ACTIVE	Yellow	Head indexing when lit
DATUM ERROR	Red	Head datum error when lit
OBSTRUCT ERROR	Red	Head obstruct error when lit, non PLUS interface fitted
OVERLOAD ERROR	Red	Head overload error when lit
TP7	Green	TP7 detected when lit
TP200	Green	TP200 detected when lit
STD	Green	TP2 / TP20 / TP6 detected when lit
SEATED	Green	Probe seated when lit
DAMPED	Yellow	Probe damped when lit

**NOTE:** The probe reset button on the front of PHC10-3 PLUS only functions if a probe interface card is installed within the unit.

# PH10 PLUS installation and user's guide

www.renishaw.com

## PHC10-3 PLUS variants

PHC10-3 PLUS is available in three options:

Standard PHC10-3 PLUS with provision for interface card to be inserted

(Renishaw part number A-5863-0100)

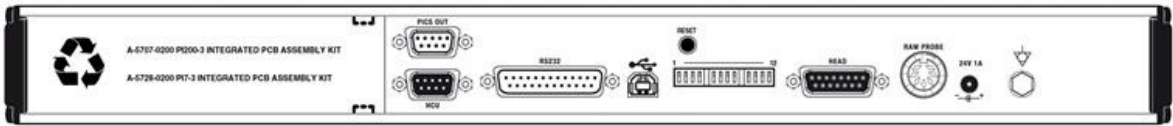

PHC10-3 PLUS with single rear panel and integrated PI 200-3 probe interface

(Renishaw part number A-5863-0200)

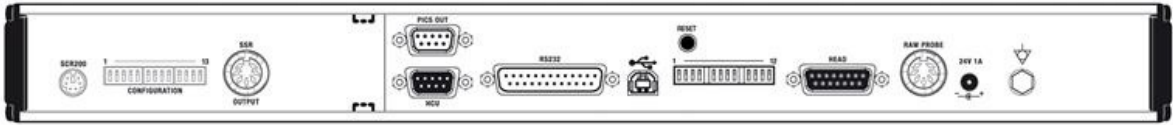

PHC10-3 PLUS with integrated PI 200-3 probe interface and additional PIC5 output

(Renishaw part number A-5863-0300)

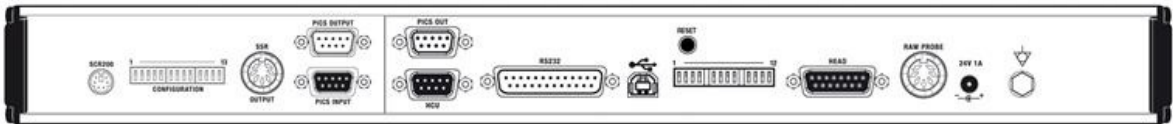

## PH10 PLUS installation and user's guide

www.renishaw.com

### Specification

<b>Repeatability of position (at a distance of 62 mm)</b>	PH10T PLUS PH10M PLUS PH10MQ PLUS	<0.4 µm TP20 and stylus <0.4 µm TP6A and stylus <0.4 µm TP6A and stylus
<b>Accuracy of step spacing from theoretical position</b>	PH10T PLUS PH10M PLUS PH10MQ PLUS	±0.24 mm TP6 probe and stylus ±0.3 mm TP6A probe and stylus ±0.3 mm TP6A probe and stylus
<b>Positioning</b>	Step A-axis 0° to 105° B-axis -180° to +180° Total	7.5° 15 positions 48 positions 720 positions
<b>Probe mounting</b>	PH10T PLUS PH10M PLUS PH10MQ PLUS	M8 thread, 18 mm diameter bush face Multiwired autojoint Multiwired autojoint
<b>Dimensions from quill face</b>	XY (all) Z (PH10T PLUS) Z (PH10M PLUS) Z (PH10MQ PLUS)	62 mm 102 mm 117 mm 73 mm
<b>Weight</b>	PH10T PLUS PH10M PLUS PH10MQ PLUS	595 g 620 g 730 g

The operating voltages of the unit are as follows:

100 V to 240 Vac +10%, -15% 47 Hz to 66 Hz 30 W maximum

### Environmental conditions

The following environmental conditions comply with those defined in BS EN61010 - 1:2001:

<b>Indoor use</b>	IP30 (no protection against liquids)
<b>Altitude</b>	Up to 2000 m
<b>Operating temperature</b>	0 °C to +50 °C
<b>Storage temperature</b>	-10 °C to +70 °C
<b>Relative humidity</b>	80% maximum for temperatures up to +31 °C
<b>Pollution degree</b>	2

# PH10 PLUS installation and user's guide

www.renishaw.com

## PH10 PLUS range dimensions

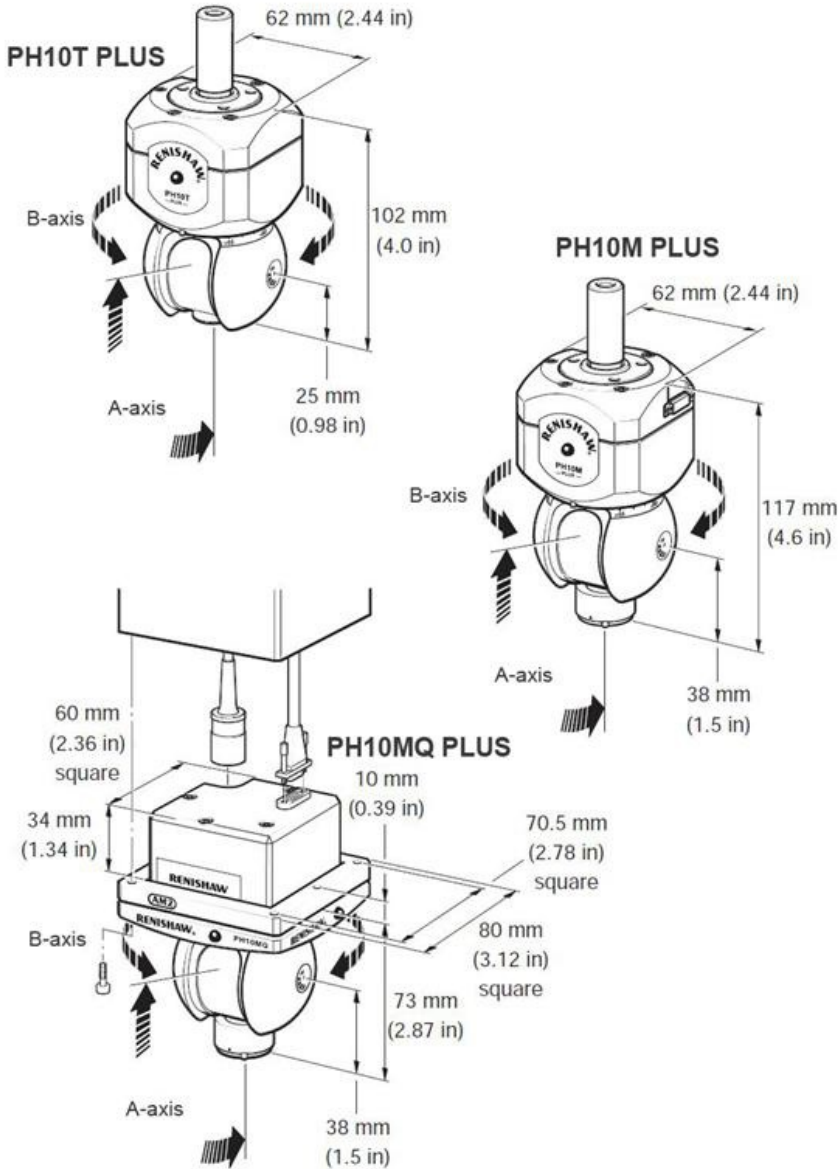

## PH10 PLUS installation and user's guide

[www.renishaw.com](http://www.renishaw.com)

# Operating modes

## Manual mode

In manual mode the optional HCU2 hand control unit is used to control head and probe functions. If the HCU2 is connected to the PHC10-3 PLUS controller when power is applied to the system, the system will enter manual mode. For further information refer to the HCU2 user's guide (part number H-1000-5361).

## Automatic mode

In automatic mode the system is under the control of the CMM computer. The HCU2 cannot be used to control head or probe functions in automatic mode. With no HCU2 fitted when power is applied to the system, the system will enter automatic mode. The system must be switched to manual mode under CMM control (and an HCU2 connected) for operation under manual mode.

Please refer to the documentation provided by your CMM supplier for further details on controlling the PH10 PLUS series of heads using the CMM computer.

**⚠ CAUTION:** Please ensure that the head is mounted as rigidly as possible in the CMM's quill. Avoid collisions between the head, workpiece or CMM bed, ensuring that the head is moved clear of any obstruction before requesting a position change. Do not apply force to any moving parts of the head and do not move the head axes by hand when locked or unlocked.

## PH10 PLUS installation and user's guide

www.renishaw.com

### Autochange racks

Renishaw's autochange racks shown are probe exchange systems available for use with the PH10M PLUS and PH10MQ PLUS probe heads. Mounted within the CMM's working envelope, the autochange system facilitates fast, automatic probe exchange without the need for requalification. Fast 'probing to probing' cycles are achieved by the head docking one probe and selecting another. Once calibrated the highly repeatable autojoint removes the need to requalify after each exchange.

#### ACR1

ACR1 is a fully integrated autochange system with eight ports. The ACR1 can be mounted vertically and has the ability to change probes from the end of extension bars.

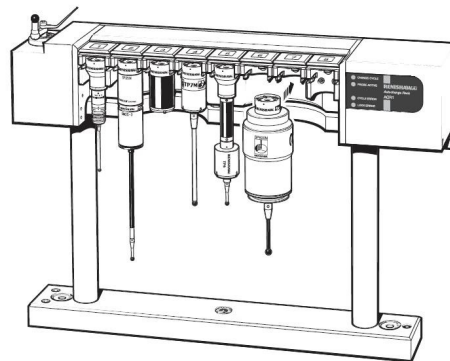

#### ACR3

ACR3 is a passive modular autochange rack with four ports and is driven by the motion of the CMM. Two ACR3s can be linked to provide an eight port system. The ACR3 is mounted on the horizontal Renishaw MRS (modular rail system).

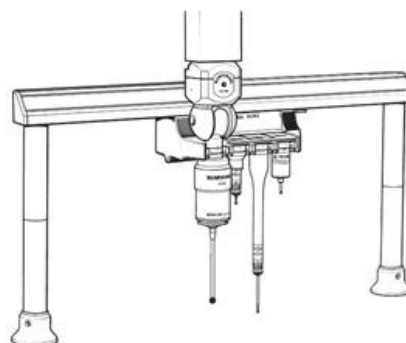

ACR3 is a passive modular autochange rack with four ports and is driven by the motion of the CMM. Two ACR3s can be linked to provide an eight port system. The ACR3 is mounted on the horizontal Renishaw MRS (modular rail system).



# PH10 PLUS installation and user's guide

www.renishaw.com

## Adjustment modules

Both modules enable adjustment in pitch, roll and yaw and allow accurate alignment with machine quill or workpiece.

### AM1 adjustment module

The AM1 adjustment module shown below is designed for use on the PH10T PLUS and PH10M PLUS. It has a quick release mechanism allowing for rapid head exchange and features inbuilt overtravel protection. For further information on the AM1, please refer to the AM1 user's guide (part number H-1000-4010).

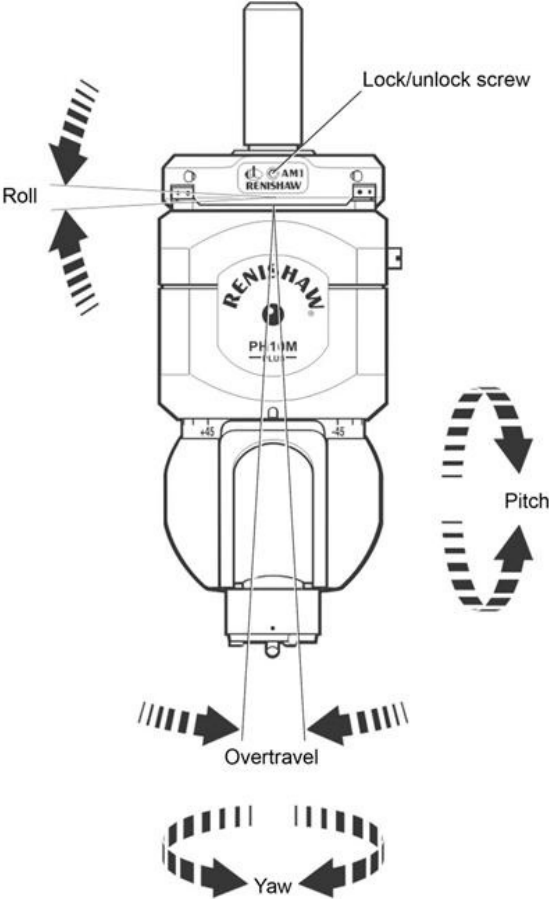

## PH10 PLUS installation and user's guide

[www.renishaw.com](http://www.renishaw.com)

### AM2 adjustment module

The AM2 adjustment module shown below is designed for use with the PH10MQ PLUS. For further information on the AM2, please refer to the AM2 product information sheet (part number H-1000-2051).

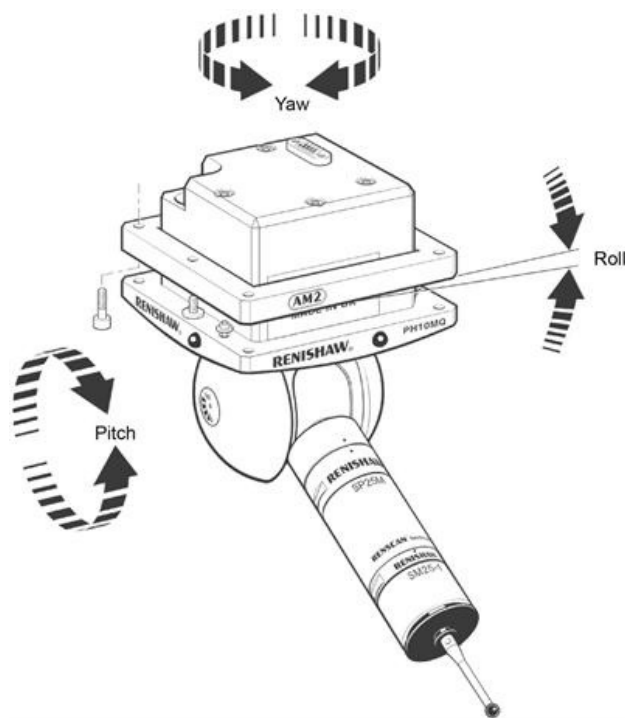

## PH10 PLUS installation and user's guide

[www.renishaw.com](http://www.renishaw.com)

### Maintenance

There are no user serviceable parts inside any PH10 PLUS system units. Units requiring attention must be returned to an authorised Renishaw customer service centre. The probe head, controller and hand control unit should be cleaned with a soft, dry, lint-free cloth.

## PH10 PLUS installation and user's guide

www.renishaw.com

# Troubleshooting

### Overload error

Possible cause	Solution
Head lock up holding force exceeded during CMM acceleration	Reduce mass of probe combination. Reduce acceleration.
Collision with workpiece or CMM	Check head for damage. Remove obstruction and repeat move.

### Obstruct error

Possible cause	Solution
Head / stylus configuration obstructed	Check head for damage. Remove obstruction and repeat move.
Probe extension combination too long	Use a shorter / lighter stylus combination.
Internal head fault	Contact your Renishaw representative.
PH10 PLUS head and non-PLUS PHC10-3 or third party controller	Contact your Renishaw representative.

### Datum error

Possible cause	Solution
Cable / connections faulty	Check condition of cabling from head to controller.
Head / stylus configuration obstructed	Remove obstruction and update head using HCU1 or under CMM control.
Probe extension combination too long	Use shorter / lighter stylus combination.
head	Contact your Renishaw representative.

### No head movement

Possible cause	Solution
Power loss	Check that controller power on LED is lit. Check mains cable condition and integrity. Check controller fuse. Check emergency stop condition.
Cable / connections faulty	Check condition of cabling from head to controller.

## PH10 PLUS installation and user's guide

www.renishaw.com

### No probe signal

Possible cause	Solution
Probe incorrectly attached	Remove probe and reattach.
Cable / connections faulty	Check condition of cabling from head to controller.
Probe failure	Contact your Renishaw representative.
Probe output disabled by CMM	Check probe output.

### Poor measurement performance

Possible cause	Solution
Loose head mounting	Ensure all mounting screws are tight and that mounting to the CMM is secure
Probe incorrectly attached	Remove probe and reattach
Force applied to head during lock up	Lock and unlock the head
Incorrect lock up position	Reposition head correctly
Position not qualified	Check qualification information

**NOTE:** Before seeking technical assistance please make a note of the following information:

- Your CMM manufacturer and model
- The probe head model
- The probe head serial number
- The head controller serial number
- The head controller version number
- The LED sequence on the PHC10-3
- The stylus configuration fitted

If you experience problems which you are not able to identify or solve satisfactorily, please contact your Renishaw representative for further advice.

## PH10 PLUS installation and user's guide

www.renishaw.com

# Appendix 1 - International safety warnings

## BG - ПРЕДУПРЕЖДЕНИЯ

 Когато върху продукта е показан този символ, потребителят трябва да направи справка с ръководството за потребителя за информация и съвет за безопасност.

Съществуват рискове от притискане между движещи се части и между движещи се и неподвижни части. Да не се държи пробникът или главата на пробника по време на работните движения, или при ръчна смяна на пробника.

Пазете се от неочаквано движение. Потребителят трябва да остава извън пълния работен обсег на комбинациите глава на пробника / удължител / пробник.

Препоръчва се защита на очите във всички приложения, включващи използване на машини или СММ.

Заменяйте изгорелите предпазители с нови от същия тип. Вж. информацията по безопасност в съответната документация за продукта.

За инструкции по отношение безопасното почистване на продуктите Renishaw вж. информацията за поддръжка в съответната документация на продукта.

Преди извършване на всякакви операции по поддръжката да се изключва захранването.

Вж. инструкциите за работа на доставчика на машината.

Отговорност на доставчика на машината е да гарантира, че на потребителя са обяснени всякакви рискове по време на работа, включително онези, упоменати в документацията на продуктите Renishaw и да гарантира осигуряване на съответни предпазители и обезопасителни блокировки.

При определени обстоятелства сигналът от пробника може да посочва фалшиво състояние на опрян пробник. Да не се разчита на сигналите от пробника за спиране движението на машината.

Ако оборудването се използва по начин, който не е указан от производителя, осигуряването от оборудването защита може да се влоши.

Очакваният метод за осигуряване на аварийно спиране за продуктите Renishaw е да се изключи захранването.

## CS - UPOZORNĚNÍ

 Jestliže je na výrobku zobrazen tento symbol, musí uživatel nahlédnout do příručky pro instalaci a obsluhu a přečíst si informace a bezpečnostní doporučení.

Mezi pohyblivými součástmi a mezi pohyblivými a statickými součástmi hrozí nebezpečí přiskřípnutí. Při přesunování nebo ručním nastavování sondy nedržte snímací hlavici.

Dejte pozor na nečekaný pohyb stroje. Uživatel by měl setrvávat mimo pracovní rozsah stroje, zejména mimo místa pohybu snímací hlavice, prodloužení a sondy.

Při jakékoli práci s obráběcími stroji nebo souřadnicovými měřicími stroji (CMM) je doporučeno používat ochranu očí.

Spálené pojistky nahradte novými pojistkami stejného typu. Pokyny naleznete v informacích o bezpečném provozu uvedených v příslušné dokumentaci k produktu.

Pokyny týkající se bezpečného čištění produktů společnosti Renishaw naleznete v části věnované informacím o údržbě v příslušné dokumentaci k produktu.

## PH10 PLUS installation and user's guide

www.renishaw.com

Před započítím jakékoliv údržby zařízení odpojte napájení.

Přečtěte si provozní pokyny dodavatele příslušného stroje.

Povinností dodavatele stroje je informovat uživatele o nebezpečích spojených s provozem i o nebezpečích zmiňovaných v dokumentaci k produktům společnosti Renishaw a zajistit dostatečné ochranné a bezpečnostní systémy.

Za určitých okolností může signál sondy nesprávně označovat klidový stav sondy. Nevyužívejte signály sondy jako hlavní impuls pro zastavování stroje.

Používá-li se zařízení způsobem, který není výrobcem specifikován, může dojít ke snížení ochrany zajištěné zařízením.

Předpokládaným způsobem nouzového zastavení produktů společnosti Renishaw je odpojení napájení.

### DA - ADVARSLER

 Når dette symbol vises på produktet, skal brugeren rådføre sig med installations- og brugervejledningen for at søge oplysninger og sikkerhedsråd.

Der er risiko for at blive klemt mellem bevægelige dele og mellem bevægelige og statiske dele. Hold ikke sondehovedet under bevægelse eller ved manuelle sondeskift.

Pas på uventede bevægelser. Brugeren bør holde sig uden for hele probehovedets/forlængerens/probekombinationernes arbejdsområde.

I alle tilfælde, hvor der anvendes værktøjs- og koordinatmålemaskiner, anbefales det at bære beskyttelsesbriller.

Udskift sikringer, der er sprunget, med nye komponenter af samme type. Se i under sikkerhed i produktdokumentationen.

Se under vedligeholdelse i produktdokumentationen for at få instruktioner til sikker rengøring af Renishaw-produkter.

Afbryd strømforsyningen, før der foretages vedligeholdelse.

Se maskinleverandørens brugervejledning

Det er maskinleverandørens ansvar at sikre, at brugeren er bekendt med eventuelle risici i forbindelse med driften, herunder de risici, som er nævnt i Renishaws produktdokumentation, og at sikre, at der er tilstrækkelig afskærmning af sikkerhedsblokeringer.

Under visse omstændigheder kan sondesignalet ved en fejl angive, at sonden står stille. Stol ikke på, at probesignaler vil stoppe maskinens bevægelse.

Hvis udstyret anvendes på en måde, som ikke er specificeret af producenten, kan udstyrets beskyttelse blive påvirket.

Den forventede metode til nødstop af Renishaw-produkter er afbrydelse strømforsyningen.

### DE - SICHERHEITSANWEISUNGEN

 Wenn dieses Symbol auf dem Produkt abgebildet ist, muss der Anwender die Informationen und Sicherheitshinweise des Installations- und Benutzerhandbuchs beachten.

Zwischen beweglichen sowie zwischen beweglichen und statischen Bauteilen besteht Einklemmgefahr. Der Dreh-/Schwenkkopf darf während des Betriebs oder einem Messtasterwechsel nicht berührt oder festgehalten werden.

Nehmen Sie sich vor unerwarteten Bewegungen in Acht. Der Anwender darf sich nur außerhalb des Messtaster-Arbeitsbereiches aufhalten.

Bei Arbeiten an Werkzeugmaschinen oder Koordinatenmessgeräten wird Augenschutz empfohlen.

## PH10 PLUS installation and user's guide

www.renishaw.com

Durchgebrannte Sicherungen dürfen nur mit gleichwertigen ersetzt werden. Beachten Sie die Sicherheitshinweise der zugehörigen Dokumentation.

Anweisungen zur sicheren Reinigung von Renishaw-Produkten finden Sie in den Wartungsinformationen der zugehörigen Produktdokumentation.

Bevor Wartungsarbeiten begonnen werden, muss die Stromversorgung getrennt werden.

Beachten Sie die Bedienungsanleitungen des Maschinenherstellers.

Es obliegt dem Maschinenlieferanten, den Anwender über alle Gefahren, die sich aus dem Betrieb der Ausrüstung, einschließlich der, die in der Renishaw Produktdokumentation erwähnt sind, zu unterrichten und sicherzustellen, dass ausreichende Schutzvorrichtungen und Sicherheitsverriegelungen eingebaut sind.

Es kann passieren, dass der Messtaster fälschlicherweise eine Ruhestellung signalisiert. Verlassen Sie sich nicht alleine auf das Signal des Mess-Systems, um Maschinenbewegungen zu stoppen.

Wird das Gerät für einen nicht vom Hersteller spezifizierten Zweck benutzt, kann dies zu einer Beeinträchtigung des vom Gerät bereitgestellten Schutzes führen.

Renishaw-Produkte im Notfall durch Ausschalten der Stromversorgung stoppen.

### EL - ΠΡΟΕΙΔΟΠΟΙΗΣΕΙΣ

 Όπου εμφανίζεται αυτό το σύμβολο επάνω στο προϊόν, ο χρήστης πρέπει να ανατρέξει στον οδηγό εγκατάστασης και στον οδηγό χρήστη, για πληροφορίες και για συμβουλές ασφαλείας.

Υπάρχει κίνδυνος πιασίματος μεταξύ των κινούμενων μερών όπως και μεταξύ των κινούμενων και στατικών μερών. Μη συγκρατείτε την κεφαλή ανιχνευτή κατά τη διάρκεια των κινήσεων ούτε και κατά τη διάρκεια χειροκίνητων αλλαγών του ανιχνευτή.

Προσέξτε τις απροσδόκητες κινήσεις. Ο χρήστης πρέπει να παραμένει εκτός του χώρου στον οποίο διεξάγονται όλοι οι συνδυασμοί λειτουργίας της κεφαλής ανιχνευτή, της προέκτασης και του ανιχνευτή.

Σε όλες τις εφαρμογές που συνεπάγονται τη χρήση εργαλείων μηχανημάτων και εξαρτημάτων CMM, συνιστάται η χρήση συσκευής προστασίας των ματιών.

Αντικαταστήστε τις καμένες ασφάλειες με νέες ασφάλειες του ίδιου τύπου. Ανατρέξτε στις πληροφορίες σχετικά με την ασφάλεια του έντυπου συνοδευτικού υλικού του αντίστοιχου προϊόντος.

Για οδηγίες σχετικά με τον ασφαλή καθαρισμό των προϊόντων Renishaw, ανατρέξτε στις πληροφορίες σχετικά με τη συντήρηση του έντυπου συνοδευτικού υλικού του αντίστοιχου προϊόντος.

Αποσυνδέστε το μηχάνημα από το ηλεκτρικό ρεύμα πριν επιχειρήσετε οποιοδήποτε εργασίες συντήρησης

Συμβουλευτείτε τις οδηγίες λειτουργίας του προμηθευτή του μηχανήματος.

Αποτελεί ευθύνη του προμηθευτή του μηχανήματος να εξασφαλίσει ότι ο χρήστης είναι ενήμερος για τυχόν κινδύνους που συνεπάγεται η λειτουργία, συμπεριλαμβανομένων όσων αναφέρονται στα εγχειρίδια του προϊόντος της Renishaw. Είναι επίσης ευθύνη του να εξασφαλίσει ότι υπάρχουν τα απαιτούμενα προστατευτικά καλύμματα και οι συνδέσεις ασφαλείας.

Υπό ορισμένες συνθήκες το σήμα του ανιχνευτή μπορεί να υποδεικνύει λανθασμένη ένδειξη τοποθέτησης του ανιχνευτή. Μη βασίζεστε στα σήματα ανιχνευτή για τη διακοπή της κίνησης του μηχανήματος.

Εάν ο εξοπλισμός χρησιμοποιείται με τρόπο μη προδιαγεγραμμένο από τον κατασκευαστή, η παρεχόμενη προστασία του εξοπλισμού πιθανώς να παρεμποδίζεται.

Η αναμενόμενη μέθοδος διακοπής έκτακτης ανάγκης για τα προϊόντα Renishaw είναι η αποσύνδεσή τους από το ηλεκτρικό ρεύμα.



## PH10 PLUS installation and user's guide

www.renishaw.com

### ES - AVISOS

 Si aparece este símbolo en el producto, el usuario deberá consultar la guía de instalación y de uso para obtener más información y consejos sobre seguridad.

Existe el peligro de atraparse los dedos entre las distintas partes móviles y entre partes móviles y fijas. No sujetar la cabeza de la sonda mientras se mueve, ni durante los cambios manuales de la sonda.

Preste atención a los movimientos imprevistos. El usuario debe quedarse fuera del grupo operativo completo compuesto por la cabeza de sonda/extensión/sonda o cualquier combinación de las mismas.

Se recomienda usar gafas de protección en todas las aplicaciones que implican el uso de Máquinas-Herramienta y máquinas de medición de coordenadas.

Reemplazar los fusibles fundidos con componentes nuevos del mismo tipo. Remitirse a la sección titulada SEGURIDAD (SAFETY) en la documentación sobre el producto.

Para instrucciones sobre seguridad a la hora de limpiar los productos Renishaw, remitirse a la sección titulada MANTENIMIENTO (MAINTENANCE) en la documentación sobre el producto

Quitar la corriente antes de emprender cualquier operación de mantenimiento.

Consulte las instrucciones de manejo del proveedor de la máquina.

Es responsabilidad del proveedor de la máquina garantizar que el operario sea informado sobre los peligros relacionados con el funcionamiento, incluidos los peligros mencionados en la documentación de los productos Renishaw, y garantizar que se suministran los dispositivos de protección y seguridad adecuados.

Bajo determinadas circunstancias la señal de la sonda puede indicar erróneamente que la sonda está asentada. No espere a las señales de la sonda para detener el movimiento de la máquina.

Si no se cumplen las indicaciones especificadas por el fabricante para la utilización del equipo, la protección del equipo puede verse dañada.

El método previsto para efectuar una parada de emergencia de los productos Renishaw es el de quitar la corriente.

### ET - HOIATUSED

 Kui seadmel on kujutatud see sümbol peab kasutaja pöörduma paigaldus- ja kasutusjuhendi poole täiendava info ja turvalise käsitsemise nõuannete saamiseks.

Masina liikuvad osad võivad põhjustada muljumisohtu. Ärge hoidke masina liikumise ajal või sondi vahetamise ajal kinni sondipeast.

Olge ettevaatlik ootamatute liikumiste suhtes. Kasutaja peab jääma väljapoole sondipea ja sondipikendi tööulatust.

Kõikide rakenduste puhul, mis kasutavad tööpinke või koordinaatmõõtemasinaid, on soovitatav kasutada silmakaitseid.

Asendage läbipõlenud kaitsemed uute sama tüüpi kaitsemetega. Täpsemad juhised leiate vastava toote dokumentide ohutusjuhiste alaosast.

Täpsemad juhised Renishaw toodete ohutuks puhastamiseks leiate vastava toote dokumentide hooldusjuhiste alaosast.

Enne hooldustööde teostamist eemaldage toide.

Vaadake masina tarnija kasutusjuhendit.

Masina tarnija vastutuseks on tagada, et kasutajat teavitatakse masina tööga kaasnevatest ohtudest, kaasa arvatud need ohud, mida on mainitud Renishaw toote dokumentides, ning samuti tagada, et masinaga oleks kaasas korrektsed kaitsepiirded ja turvalukud.

## PH10 PLUS installation and user's guide

www.renishaw.com

Teatud tingimustel võib sondi signaal valesti viidata sondiga seotud olukorrale. Ärge lootke masina liikumise peatamiseks sondi signaalile.

Kui seadet kasutatakse viisil, mis ei ole tootja poolt ette nähtud, võib seadme pakutav kaitse väheneda.

Esmaseks masina hädaseiskamise meetodiks Renishaw toodete puhul on elektritoite katkestamine.

### FI - VAROITUS

 Kun tuotteessa näkyy tämä symboli, käyttäjän tulee tutustua asennus- ja käyttöoppaassa esitettäviin lisätietoihin ja turvallisuusohjeisiin.

Liikkuvien osien sekä liikkuvien ja staattisten osien välillä on olemassa puristusvaara. Älä pidä kiinni anturin päästä sen liikkuessa tai vaihtaessasi anturia käsin.

Varo odottamatonta liikettä. Käyttäjän tulee pysyä mittapäät/jatke/anturi-yhdistelmien toiminta-alueen ulkopuolella,

Silmäsuojainten käyttö on suositeltavaa kaikkia työstökoneita ja koordinaattimittauskoneita (CMM) käytettäessä.

Korvaa palaneet sulakkeet samantyyppisillä uusilla sulakkeilla. Lue tuoteselosteen TURVALLISUUTTA (SAFETY) koskeva osa.

Renishaw-tuotteiden turvalliset puhdistusohjeet löytyvät kunkin tuotteen dokumenttien kunnossapito-kohdasta.

Katkaise virta ennen huoltotoimenpiteiden suorittamista.

Tutustu laitteen toimittajan käyttöohjeisiin.

Laitteen toimittajan vastuulla on varmistaa, että käyttäjä on tietoinen laitteen käyttöön liittyvistä vaaratekijöistä, mukaan lukien Renishaw'n tuotedokumenteissa mainitut vaaratekijät, ja varmistaa, että asiakas saa asianmukaiset suojalaitteet ja varmistimet.

Tietyissä olosuhteissa anturilta tuleva signaali saattaa virheellisesti osoittaa, että mitta-anturi on lepotilassa (=ei-kosketuksessa). Älä luota koneen pysähtyvän probin signaaleista.

Jos laitetta käytetään valmistajan ohjeista poikkeavalla tavalla, sen suojavaikutus voi olla puutteellinen.

Renishaw-tuotteiden hätäpysäytys tehdään tavallisesti kytkemällä virta pois päältä.

### FR - SECURITE

 Lorsque ce symbole est affiché sur le produit, l'utilisateur doit consulter le manuel d'installation et d'utilisation pour y trouver des informations et des conseils de sécurité.

L'effet de pincement dû au mouvement des pièces mobiles entre elles ou avec des pièces fixes présente des dangers. Ne pas tenir la tête du palpeur lorsqu'elle se déplace ou que le palpeur est changé à la main

Attention aux mouvements brusques. L'utilisateur doit toujours rester en dehors de la zone de sécurité des installations multiples  
Tête/Rallonge/Palpeur

Le port de lunettes de protection est recommandé pour toute application sur machine-outil et MMT.

Remplacer les fusibles grillés par des composants neufs du même type. Consulter les consignes de sécurité de votre documentation.

Les conseils de nettoyage en toute sécurité des produits Renishaw figurent dans les consignes de maintenance de votre documentation.

Mettre la machine hors tension avant d'entreprendre toute opération de maintenance.

Consulter le mode d'emploi du fournisseur de la machine.

Il incombe au fournisseur de la machine d'assurer que l'utilisateur prenne connaissance des dangers d'exploitation, y compris ceux décrits

## PH10 PLUS installation and user's guide

www.renishaw.com

dans la documentation du produit Renishaw, et d'assurer que des protections et verrouillages de sûreté adéquats soient prévus.

Dans certains cas, il est possible que le signal du palpeur indique à tort l'état que le palpeur est au repos. Il ne faut pas se fier aux signaux venant du palpeur car ils ne garantissent pas toujours l'arrêt de la machine.

Toute utilisation de ce matériel d'une manière non spécifiée par le constructeur peut compromettre la protection dont est pourvu cet équipement.

La procédure habituelle d'arrêt d'urgence des produits Renishaw est la mise hors tension.

### GA - RABHAIDH

 Nuair a thaispeántar an tsiombail seo ar an táirge, féachtar an treoir suiteála agus úsáideoirí, áit a bhfuil faisnéis agus comhairle shábháilteachta.

Tá guaiseacha cúngúcháin ann idir páirteanna atá ag gluaiseacht agus idir páirteanna atá ag gluaiseacht agus páirteanna statacha. Ná coinnigh greim ar cheann an tóireadóra le linn gluaiseachtaí, nó nuair atá tóireadóir á athrú de láimh.

Fainic an chorraíl gan choinne. Ba chóir don úsáideoir fanacht lasmuigh d'imchlúdach iomlán oibre an chinn tóireadóra/bhreisithe/na dteaghlaimí tóireadóra.

Moltar cosaint do na súile i ngach aon fheidhmiú lena mbaineann úsáid uirlisí meaisín nó CMM.

Déan fiúsanna séidte a athsholáthar le comhpháirteanna den chineál céanna. Tagair don fhaisnéis shábháilteachta i gcáipéisíocht ábhartha an táirge.

Atsholáthair fiúsanna séidte le comhpháirteanna den chineál céanna. Tagair don fhaisnéis shábháilteachta i gcáipéisíocht ábhartha an táirge.

Féach an fhaisnéis chothabhála sa cháipéisíocht a théann leis an táirge bainteach chun teoracha a fháil faoi tháirgí Renishaw a ghlanadh go sábháilte.

Baintear an chumhacht de sula ndéantar aon oibríochtaí cothabhála.

Féach na teoracha oibríúcháin ó sholáthraí an mheaisín.

Tá sé de dhualgas ar sholáthraí an mheaisín a chinntiú go dtugtar le fios don úsáideoir na guaiseacha a bhaineann leis an oibriú, lena n-áirítear iad sin a luaitear i gcáipéisíocht Renishaw faoina dtáirgí féin, agus a chinntiú go soláthraítear comhghlasáil agus cibé cosaint leordhóthanach eile atá riachtanach.

D'fhéadfadh an tóireadóir comhartha a thabhairt, ar chúinsí áirithe, go bhfuil rud éigin cearr leis go bréagach. Ná braitear ar chomharthaí tóireadóra le gluaiseacht an mheaisín a stopadh.

Má úsáidtear an trealamh ar bhealach nach bhfuil sonraithe ag an déantúsóir, tharlódh go ndéanfaí dochar don chosaint a sholáthraíonn an trealamh.

### HU - FIGYELMEZTETÉSEK

 Amikor ezt a szimbólumot látja a terméken, kérjük, tekintse meg a telepítési és használati útmutatót további információ és biztonsági ajánlások végett.

A mozgó alkatrészek között és a mozgó és statikus alkatrészek között beszorulás veszélye áll fenn. Ne fogja meg a tapintót, vagy a tapintófejet mozgás közben.

Vigyázzon, mert a gép váratlanul elindulhat. Tartózkodjon a tapintófej és hosszabbítójának teljes mozgáskörzetén kívül!

## PH10 PLUS installation and user's guide

www.renishaw.com

Szerszámgépek és koordináta-mérőgépek használata során mindig javasolt a szemvédő viselése.

A kiégett biztosítékokat ugyanolyan típusú, új alkatrészsel cserélje ki. Olvassa el a megfelelő termékismertető BIZTONSÁG-gal kapcsolatos fejezetét.

A Renishaw szerszámgépek biztonságos tisztítására vonatkozó előírásokat megtalálja a megfelelő termékismertető, karbantartás fejezetében.

Bármilyen karbantartási művelet kivitelezése előtt áramtalanítsa a gépet.

További tudnivalók a gép szállítójának használati utasításában találhatók.

A gép szállítója azért felelős, hogy felhívja a felhasználó figyelmét az üzemeltetéssel kapcsolatos veszélyforrásokra, beleértve a Renishaw termékdokumentációjában ismertetetteket is. Továbbá gondoskodnia kell a megfelelő védőburkolatok és biztonsági reteszelvek meglétéről is.

Bizonyos körülmények között, a tapintófej tévesen is jelezhet mechanikus érintkezést. Ezért nem szabad a tapintófejre bízni a gép leállítását.

Ha a felszerelést a gyártó által előírt módtól eltérő módon használják, a felszerelés által nyújtott védelem érvénytelenné válik.

A Renishaw termékek vészleállításának elvárt módszere a berendezés kikapcsolása.

### IT - SICUREZZA

 Se questo simbolo è riportato sul prodotto, l'utente deve consultare la Guida di installazione e il Manuale dell'utente per ottenere informazioni e consigli su un utilizzo sicuro.

Esiste pericolo di danno da schiacciamento tra le parti in moto o tra le parti in moto e quelle ferme. Evitare di afferrare la testa della sonda quando è in moto, oppure quando la sonda viene cambiata manualmente.

Fare attenzione ai movimenti improvvisi. Si raccomanda all'utente di tenersi al di fuori dello spazio operativo della testa della sonda, delle prolunghie e di altri accessori della sonda.

Si raccomanda di indossare occhiali di protezione in applicazioni che comportano l'utilizzo di macchine utensili e macchine CMM.

I fusibili bruciati dovranno essere sostituiti con altri dello stesso tipo. Consultare le informazioni di sicurezza nella documentazione dello specifico prodotto.

Per le istruzioni relative alla pulizia dei prodotti Renishaw, fare riferimento alle informazioni sulla manutenzione della documentazione del prodotto.

Prima di effettuare qualsiasi intervento di manutenzione, disconnettersi dalla rete di alimentazione.

Consultare le istruzioni d'uso fornite dal fabbricante della macchina.

Il fornitore della macchina ha la responsabilità di avvertire l'utente dei pericoli inerenti al funzionamento della stessa, compresi quelli riportati nelle istruzioni di Renishaw, e di fornire dispositivi di protezione e interruttori di esclusione adeguati.

È possibile che in certe situazioni venga erroneamente prodotto un segnale che indica che la sonda è in posizione. Non fare affidamento sui segnali di stato sonda per arrestare il movimento della macchina.

Se utilizzato in modo non conforme a quanto specificato dal produttore, il dispositivo potrebbe non fornire il livello di protezione previsto.

Il metodo corretto di eseguire un arresto di emergenza per i prodotti Renishaw è l'interruzione dell'alimentazione elettrica.

## PH10 PLUS installation and user's guide

www.renishaw.com

### LT - ĮSPĖJIMAI

Kai ant gaminio rodomas simbolis , naudotojas privalo informacijos ir saugos rekomendacijų ieškoti įrengimo naudotojo vadove.

Tarp judančių detalių bei tarp judančių ir statišku detalių pakliuvę daiktai gali būti suspausti. Nelaikykite zondo galvutės veikiant įrenginiui ar keisdami zondą rankiniu būdu.

Saugokitės netikėtų judesių. Naudotojui nerekomenduojama atidaryti veikiančios zondo galvutės / ilgintuvo / zondų junginio gaubto.

Dirbant visus darbus, naudojant įrenginio įrankius ar valant ir prižiūrint įrenginį, rekomenduojama užsidėti apsauginius akinius.

Pakeiskite perdegusius saugiklius to paties tipo saugikliais. Laikykites atitinkamos techninės gaminio dokumentacijos saugos nurodymų.

„Renishaw” gaminių saugaus valymo instrukcijas rasite priežiūros nurodymuose, pateikiamuose kartu su gaminiu.

Prieš atlikdami techninę priežiūrą, išjunkite elektros srovės tiekimą.

Laikykites įrenginio tiekėjo naudojimo nurodymų.

Įrenginio tiekėjas atsako už tai, kad naudotojas būtų įspėtas apie pavojus, susijusius su įrenginio naudojimu, taip pat pavojus, minimus „Renishaw” prietaiso techninėje dokumentacijoje, ir kad būtų sumontuoti atitinkami apsauginiai įrenginiai bei blokatoriai.

Susiklosčius tam tikroms aplinkybėms, zondo signalas gali neteisingai informuoti, kad jo reikšmės nustatytos į pradinę būseną. Nepasikliaukite zondo signalais ir iš karto nestabdykite įrenginio.

Jeigu įranga naudojama ne taip, kaip nurodo gamintojas, gali sumažėti įrangos teikiama apsauga.

Tinkamiausias būdas sustabdyti Renishaw prietaisą yra nutraukti elektros srovės tiekimą.

### LV - BRĪDINĀJUMS

 Ja uz izstrādājuma ir redzams šis simbols, lietotājam jāizlasa uzstādīšanas un lietošanas pamācībā sniegtā informācija un padomi par drošību.

Pastāv risks tikt saspiestam starp kustīgajām daļām, ka arī kustīgajām un nekustīgajām daļām. Nepieskarieties ar rokām zondei kustības laikā vai mainot zondi.

Uzmanieties no negaidītas kustības. Lietotājam jāpaliek ārpus zondes/uzgaļa/kontaktmērgalviņas pilna darbības rādiusa.

Aizsargājiet acis, strādājot ar darbgaldiem vai koordinātu mērīšanas ierīcēm.

Aizvietojiet izdegušus drošinātājus ar tā paša veida jauniem komponentiem. Skatiet drošības tehnikas informāciju attiecīgā izstrādājuma dokumentācijā.

Instrukcijas drošai Renishaw izstrādājumu tīrīšanai ir iekļautas apkalpošanas informācijā atbilstošā izstrādājuma dokumentācijā.

Atvienojiet no strāvas pirms jebkuru apkalpošanas darbu veikšanas.

Skatiet iekārtas piegādātāja ekspluatācijas instrukcijas.

Iekārtas piegādātājs atbild par to, lai lietotājs būtu iepazstināts ar jebkuriem draudiem, kas saistīti ar tās darbību (ieskaitot tos, kas minēti Renishaw izstrādājuma dokumentācijā), un lai būtu nodrošinātas atbilstošas aizsargierīces un aizsargbloķētāji.

Noteiktos apstākļos zondes signāls var nepareizi norādīt zondes stāvokli. Nepaļaujieties uz zondes signālu, lai apturētu iekārtas kustību.

Ja aparatūra tiek lietota veidā, kas neatbilst ražotāja norādītajam, tas var ietekmēt iekārtas drošību.

Tiek pieņemts, ka Renishaw izstrādājumu avārijas apturēšanai lietotājs to atvienos no strāvas.

## PH10 PLUS installation and user's guide

www.renishaw.com

### MT - TWISSIJET

 Kull fejn jintwera dan is-simbolu fuq il-prodott, l-utent irid jirreferi għall-gwida tal-utent u l-gwida dwar l-installazzjoni għal informazzjoni u pariri dwar is-sigurtà.

Hemm il-periklu li wieħed jinqaras bejn partijiet li jiċċaqilqu u bejn biċċiet li jiċċaqilqu u biċċiet partijiet. Iżzomm ir-ras tas-sonda waqt il-moviment, jew meta tkun qiegħed/qiegħda tibdel sonda.

Oqgħod attenta/a għal moviment mhux mistenni. L-utent għandu jibqa' barra ż-żona kollha tal-operat tal-kombinazzjonijiet tar-ras tas-sonda/estensjoni/sonda.

Fix-xogħol kollu li jinvolvu l-użu ta' għodda tal-magni jew CMMs, il-protezzjoni tal-għajnejn hija rakkommandata.

Ibdel f'usijiet li taru b'komponenti godda ta' l-istess tip. Irreferi għall-informazzjoni tas-sigurtà fid-dokumentazzjoni rilevanti tal-prodott.

Għal struzzjonijiet dwar it-tindif bla periklu tal-prodotti ta' Renishaw, irreferi għall-informazzjoni dwar il-manutenzjoni fid-dokumentazzjoni rilevanti tal-prodott rilevanti.

Irfi d-dawl qabel ma tagħmel xi xogħol ta' manutenzjoni.

Irreferi għall-istruzzjonijiet tal-operat tal-fornitur tal-magna.

Hija r-responsabbiltà tal-fornitur tal-magna li jiżgura li l-utent ikun konxju ta' kwalunkwe perikli involuti fit-tħaddim, inklużi dawk imsemmija fid-dokumentazzjoni tal-prodotti Renishaw, u li jiżgura li hemm protezzjoni u l-interlocks tas-sigurtà adegwati pprovduti.

Taħt certi ċirkustanzi, s-sinjali tas-sonda jista' jindika b'mod falz kundizzjoni ta' sonda mhux attiva. Tiddependix fuq is-sinjali tas-sonda sabiex twaqqaf il-moviment tal-magna.

Jekk dan it-tagħmir jintuza b'mod li ma jkunx speċifikat mill-manifattur, il-protezzjoni pprovduta mit-tagħmir tista' titnaqqas.

Il-metodu mistenni ta' li jiġi provdut waqfien ta' emerġenza għal prodotti ta' Renishaw huwa li jintefa' d-dawl. TWISSIJET

### NL - WAARSCHUWINGEN

 Wanneer dit symbool zich op het product bevindt, dient de gebruiker de installatie- en gebruikersgids te raadplegen voor informatie en veiligheidsadvies.

Er is risico op inklemming tussen de bewegende onderdelen onderling en tussen bewegende en niet-bewegende onderdelen. Houd de tasterkop niet vast als de machine in werking is of bij het handmatig verwisselen van een taster.

Wees bedacht op onverwachte bewegingen. De gebruiker dient buiten het bereik van de werkende tasterkop/verlengstuk/taster combinaties te blijven.

Voor alle toepassingen met bewerkingsmachines of CMM's wordt aanbevolen een veiligheidsbril te dragen.

Vervang doorgebrande zekeringen door nieuwe van hetzelfde type. Lees de veiligheidsinstructies in de bijbehorende productdocumentatie.

Raadpleeg voor het veilig reinigen van Renishaw producten de onderhoudsinstructies in de betreffende productdocumentatie.

Verbreek de stroomtoevoer voordat u onderhoudswerk gaat verrichten.

Raadpleeg de bedieningshandleiding van de machineleverancier.

De leverancier van de machine dient te zorgen dat de gebruiker op de hoogte is van de risico's die zijn verbonden aan het gebruik van de machine, met inbegrip van de risico's vermeld in de productdocumentatie van Renishaw, en dat de machine is voorzien van voldoende beveiligingen en veiligheidsvergrendelingen.

Onder bepaalde omstandigheden kan het tastersignaal een onjuiste tastertoestand aangeven. Vertrouw niet op de tastersignalen om de

## PH10 PLUS installation and user's guide

www.renishaw.com

machine tot stilstand te brengen.

Gebruik van de apparatuur op een manier die de fabrikant niet voorgeschreven heeft, kan het apparaat beschadigen of de bescherming beperken.

U kunt in geval van nood de Renishaw apparatuur stopzetten door de stroom uit te schakelen.

### PL - OSTRZEŻENIA

 Jeżeli symbol ten znajduje się na produkcie, należy zapoznać się z instrukcją i podręcznikiem użytkownika, aby uzyskać informacje dotyczące bezpieczeństwa.

Występuje niebezpieczeństwo zakleszczenia pomiędzy częściami ruchomymi oraz częściami ruchomymi i nieruchomymi. Nie wolno trzymać głowicy sondy podczas wykonywania przemieszczeń ani podczas ręcznej zmiany sondy.

Należy uważać na nieoczekiwane przemieszczenia maszyny. Użytkownik powinien pozostawać poza pełnym zasięgiem roboczym zespołu głowica sondy/łącznik przedłużający/sonda.

Podczas obsługi obrabiarek lub maszyn współrzędnościowych zaleca się używanie osłon na oczy.

Spalone bezpieczniki topikowe zastępować nowymi elementami tego samego typu. W dokumentacji odpowiedniego produktu zapoznaj się z informacjami dotyczącymi bezpieczeństwa.

Aby zapoznać się z instrukcjami dotyczącymi bezpiecznego czyszczenia produktów firmy Renishaw, należy przejść do rozdziału z informacjami dotyczącymi konserwacji w dokumentacji odpowiedniego produktu.

Przed przystąpieniem do jakichkolwiek czynności konserwacyjnych należy odłączyć zasilanie energią elektryczną.

Należy zapoznać się z instrukcjami obsługi dostarczonymi przez dostawcę urządzeń.

Na dostawcy maszyny współrzędnościowej spoczywa odpowiedzialność za uprzedzenie użytkownika o wszelkich zagrożeniach związanych z eksploatacją łącznie z tymi, o jakich wspomina się w dokumentacji produktu Renishaw oraz za zapewnienie stosownych osłon i blokad zabezpieczających.

W określonych warunkach sygnał sondy może fałszywie wskazywać stan gotowości sondy. Nie należy zatrzymywać pracy maszyny tylko z powodu fałszywego sygnału sondy.

Jeżeli wyposażenie jest użytkowane w inny sposób niż określił to producent, zabezpieczenie zapewniane przez to wyposażenie może być osłabione.

Zalecaną metodą zapewnienia awaryjnego zatrzymania działania produktów firmy Renishaw jest odłączenie zasilania energią elektryczną.

### PT - ATENÇÃO

 Quando este símbolo é exibido no produto, o usuário deve consultar as instruções de instalação e o manual do usuário para informações sobre segurança.

Existe perigo de esmagamento entre as peças móveis/estáticas do equipamento. Não segure o apalpador ou o cabeçote do apalpador durante os movimentos.

Tome cuidado com movimentos inesperados. O usuário deve permanecer fora da área de trabalho das combinações do cabeçote/extensão/apalpador.

Em todas as aplicações que envolvam a utilização de Máquinas-Ferramenta e CMMs, recomenda-se a utilização proteção para os olhos.

## PH10 PLUS installation and user's guide

www.renishaw.com

Substituiți os fusíveis danificados por fusíveis novos do mesmo tipo. Consultar a seção SEGURANÇA (SAFETY) na documentação do produto.

Para instruções relativas à limpeza dos produtos Renishaw em segurança, consultar a seção MAINTENANCE (MANUTENÇÃO) da documentação do produto.

Desligar a alimentação de energia antes de efetuar qualquer operação de manutenção.

Consultar as instruções de operação do fornecedor da máquina.

É responsabilidade do fornecedor da máquina garantir que o usuário está ciente dos perigos envolvidos na operação, incluindo os mencionados na documentação dos produtos Renishaw, e assegurar que foram fornecidas todas as proteções apropriadas e bloqueios de segurança.

Sob certas circunstâncias, o sinal do apalpador pode falsamente indicar uma condição de contato do apalpador. Não se basear em sinais de apalpador para interromper o movimento da máquina.

Se o equipamento for utilizado de modo não especificado pelo fabricante, a proteção oferecida pelo equipamento poderá ser prejudicada.

O método sugerido para uma parada de emergência de produtos Renishaw é desligar a alimentação de energia.

### RO - ATENȚIONĂRI

 În punctele marcate pe produs cu acest simbol utilizatorul trebuie să consulte manualul de utilizare și recomandările de securitate.

Există riscul prinderii pielii atât între piesele în mișcare cât și între piesele în mișcare și cele fixe. Nu țineți de capul palpatorului în timpul deplasării acestuia sau în timpul schimbării manuale a palpatorului propriu-zis.

Atenție la deplasările neașteptate. Operatorul trebuie să rămână complet în afara zonei de acțiune a ansamblului cap palpator/prelungitor/palpator propriu-zis.

În toate aplicațiile care presupun utilizarea mașinilor unelte sau a MMC, se recomandă protejerea ochilor.

Înlocuiți siguranțele arse numai cu componente noi de aceeași valoare. Vezi capitolul SIGURANȚĂ al documentației fiecărui produs implicat.

Pentru instrucțiuni referitoare la curățirea în siguranță a produselor Renishaw, vezi capitolul Întreținere al documentației fiecărui produs implicat.

Înainte de executarea oricăror operații de întreținere, scoateți echipamentul de sub tensiune.

Vezi și instrucțiunile de operare ale furnizorului echipamentului.

Este responsabilitatea furnizorului să se asigure că utilizatorul a fost înștiințat asupra oricărui pericol implicat de utilizarea echipamentului, inclusiv asupra pericolelor menționate în documentația produsului Renishaw, și de asemenea să se asigure că au fost prevăzute protecții și interblocări adecvate.

În anumite circumstanțe, palpatorul poate indica o atingere, în mod eronat. Nu vă bazați pe semnalele primite de la palpator pentru a opri deplasarea mașinii.

Dacă echipamentul este folosit în alt fel decât cel specificat de producător protecția oferită de acesta poate fi diminuată.

Metoda recomandată pentru efectuarea unei opriri de urgență în cazul produselor Renishaw este scoaterea echipamentului de sub tensiune.



## PH10 PLUS installation and user's guide

www.renishaw.com

### SK - VÝSTRAHY

 Ak je uvedený na výrobku tento symbol, používateľ si musí prečítať informácie a bezpečnostné odporúčania v inštaláčnej a používateľskej príručke.

Medzi pohyblivými časťami a medzi pohyblivými a statickými časťami vzniká riziko pomliaždenia. Snímaciu hlavicu počas pohybu alebo pri ručnej výmene sondy nechyťajte.

Dávajte si pozor na neočakávaný pohyb. Používateľ by mal zostať mimo celej pracovnej dráhy zostavy snímačej hlavice, ramena a sondy.

Vo všetkých aplikáciách zahŕňajúcich používanie obrábacích strojov alebo súradnicových meracích prístrojov sa odporúča ochrana očí.

Prepálené poistky vymeňte za nové rovnakého typu. Pozrite si bezpečnostné informácie v dokumentácii k príslušnému produktu.

Pokyny týkajúce sa bezpečného čistenia produktov spoločnosti Renishaw získate v informáciách o údržbe uvedených v dokumentácii k príslušnému produktu.

Pred každým vykonávaním údržby odpojte napájanie.

Pozrite si prevádzkové pokyny dodávateľa stroja.

Zodpovednosťou dodávateľa stroja je zaručiť oboznámenie používateľa so všetkými rizikami súvisiacimi s prevádzkou, vrátane tých, ktoré sú uvedené v dokumentácii k produktu spoločnosti Renishaw, a zaručiť poskytnutie adekvátnych zábran a bezpečnostných blokování.

Signál sondy môže za určitých okolností nesprávne indikovať parkovaciu polohu sondy. Pri zastavovaní pohybov stroja sa nespoliehajte na signály sondy.

Ak sa zariadenie používa spôsobom iným ako špecifikovaným výrobcom, môže to eliminovať ochranu poskytovanú zariadením.

Predpokladaný spôsob núdzového zastavenia zariadení spoločnosti Renishaw spočíva v odpojení napájania.

### SL - OPOZORILA

 Če je na izdelku nameščen ta simbol, mora uporabnik upoštevati informacije in nasvete glede varnosti v navodilih za inštalacijo in v navodilih za uporabnika.

Ob gibanju delov obstaja nevarnost uščipa, zato med ročno menjavo sonde ne držite merilne glave.

Bodite pozorni na nepričakovane premike. Zadržujte se zunaj delovnega območja sonde/podaljška/merilne glave.

Ob uporabi obdelovalnih strojov ali koordinatnih merilnih strojov priporočamo uporabo zaščitnih očal.

Pregorele varovalke zamenjajte z novimi komponentami istega tipa. Glejte varnostne napotke v ustrezni produktni dokumentaciji.

O varnem načinu čiščenja izdelkov Renishaw si preberite razdelek Vzdrževanje v odgovarjajoči dokumentaciji.

Pred začetkom vzdrževanja stroj izklopite iz električnega omrežja.

Držite se navodil dobavitelja stroja.

Odgovornost dobavitelja stroja je, da uporabnika opozori na vse nevarnosti pri delovanju, tudi na tiste, ki so navedene v Renishaw-jevi dokumentaciji, in da zagotovi vsa potrebna varovala in varnostne zapore.

Signal glave lahko v določenih pogojih lažno javlja, da je sonda spravljená, zato se pri zaustavitvi stroja ne zanašajte nanje.

Uporaba opreme na način, ki odstopa od predpisanega, lahko poslabša varnost izdelka.

Pričakovana metoda za zaustavitev v sili za Renishaw-ove izdelke je odvzem napajanja.

## PH10 PLUS installation and user's guide

[www.renishaw.com](http://www.renishaw.com)

### SV - VARNINGAR

 Om den här symbolen visas på en produkt betyder det att användaren måste se installations- och bruksanvisningen för information och råd om säkerheten.

Det finns risk för klämning mellan rörliga delar och mellan rörliga och stillastående delar. Håll inte i probhuvudet under rörelse eller vid manuellt probbyte.

Se upp för plötsliga rörelser. Operatören ska hålla sig utanför arbetsområdet för probhuvud/förlängning/probkombinationer.

Ögonskydd rekommenderas för alla tillämpningar, där verktygsmaskiner eller koordinatmätmaskiner används.

Byt trasiga säkringar mot nya av samma typ. Se säkerhetsavsnittet i produktdokumentationen.

Se underhållsinformationen i relevant produktdokumentation för instruktioner angående säker rengöring av Renishaws produkter.

Koppla bort strömmen innan underhåll utförs.

Se maskintillverkarens bruksanvisning.

Maskinleverantören ansvarar för att användaren informeras om de risker som drift innebär, inklusive de som nämns i Renishaws produktdokumentation, samt att tillräckliga skydd och säkerhetsföreglingar tillhandahålls.

Under vissa omständigheter kan probsignalen felaktigt ange att en prob är monterad. Lita inte på probsignaler för att stoppa maskinens rörelse.

Om utrustningen används på ett sätt som inte tillverkaren har avsett kanske skyddet fungerar sämre.

Metoden för nödstopp för Renishaws produkter förutsätter att strömmen kopplas bort.

**Renishaw plc**  
New Mills, Wotton-under-Edge,  
Gloucestershire, GL12 8JR  
United Kingdom

T +44 (0)1453 524524  
F +44 (0)1453 524901  
[www.renishaw.com/cmmsupport](http://www.renishaw.com/cmmsupport)

**RENISHAW**   
apply innovation™

For worldwide contact details,  
please visit our main website at  
[www.renishaw.com/contact](http://www.renishaw.com/contact)