

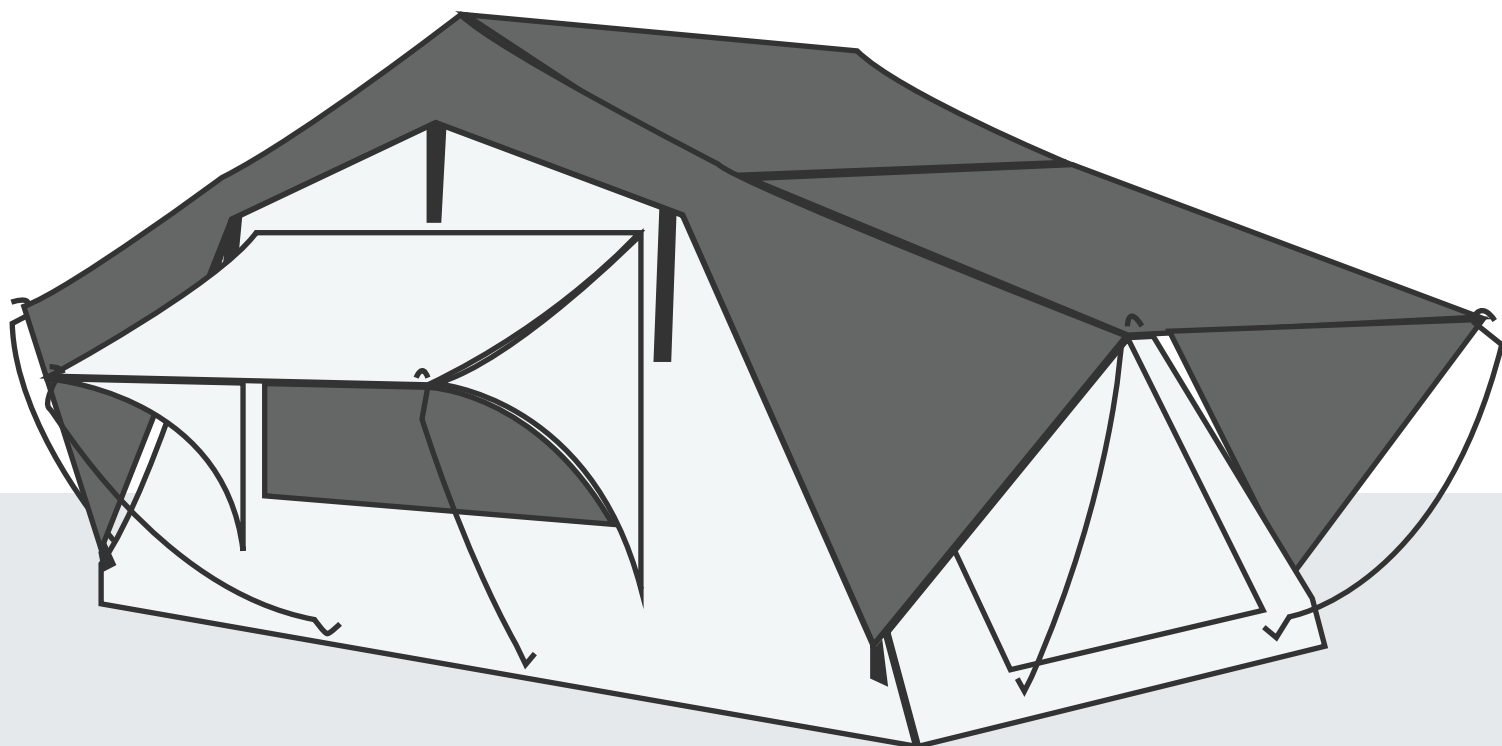

Nomadic Standard Roof Top Tent



**CAREFULLY READ INSTRUCTIONS PRIOR
TO THE FIRST USE OF THE
NOMADIC STANDARD ROOF TOP TENT**

GET TO KNOW YOUR NOMADIC STANDARD RTT

We recommend you check all parts are included prior to first use.

COMPONENTS NEEDED

8x 13mm Steel Bolt
8x 10mm x 40mm Bolt
2x 10mm x 20mm Steel Bolt
8x 10mm Nylock Nut
8x 13mm Nylock Nut

2x Ladder Mounting Bracket
14x Stainless Steel Washer
2x Rubber Washer
1x Metric Wrench 10mm
1x Metric Wrench

13mm/15mm
8x Channel Slider
4x Steel Mount Plate
2x Mounting Tracks

GETTING STARTED

1

Remove tent box and place on a clean surface.

Undo all the Velcro straps so that you can open the tent enough to unzip the door and remove the contents.

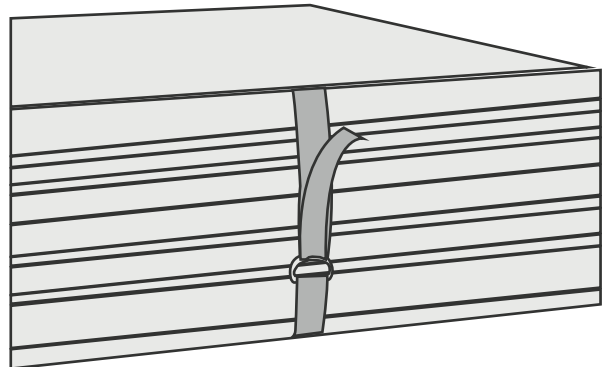

TENT ORIENTATION ON YOUR VEHICLE

There are two mounting options for the orientation of your new Overland Vehicle Systems Tent. Either the tent will open so that the ladder extends off the back of your vehicle, "Rear Mounted," or the ladder extends off the side of your vehicle, "Side Mounted." Most of your customers choose to mount their tents with the ladder extending off the side of the vehicle, in "Side Mounted" orientation.

Either orientation works for larger vehicles, however, most sedans or smaller SUVs are better suited for the side mounted option.

Benefits of a rear mounted tent:

Fits into narrow camping spaces.

1. Trunk or tail gate area at the rear of your vehicle is accessible from inside the annex

Benefits of a side mounted tent

1. Allows for bicycle racks and other tow hitch / bar accessories to be installed without interfering with your tent operation.
2. Closed tent width will fit inside the roof dimensions of most cars and SUV's. i.e. the tent base will not extend beyond the roofline of your vehicle when closed.
3. Typically, does not require cutting of the mounting tracks.

TENT ASSEMBLY

2

Four pre-drilled holes are in the center area of the tent base for attaching the mounting tracks. Align the holes in the mounting tracks over the holes in the base.

Rear Mounted

- Mount Perpendicular to Hinge

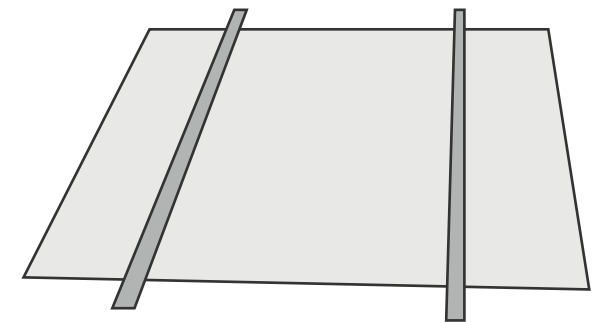

Rear Mounted

- Mount parallel to hinge

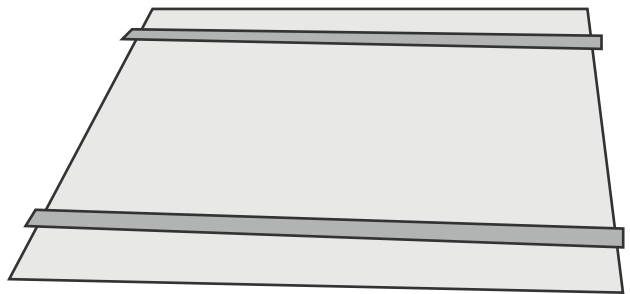

3

Slide the 10mm nylock nuts into the inner slot in the center of the mounting tracks until they are aligned with the holes in the mounting tracks and the base.

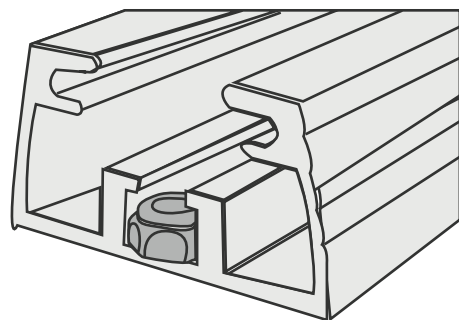

Using the supplied 10mm bolts, add two steel washers to each bolt. Slide your hand between base and mattress and insert bolts with washers into the pre-drilled holes. You may need to poke holes through the tape to insert bolts. The bolts should pass through the holes in the tent base and the mounting tracks, into the nuts in the inner slot of the mounting track. Reach under the mattress and tighten the bolts firmly using the supplied 10mm wrench

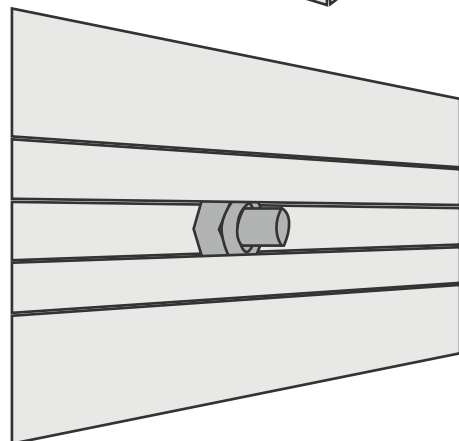

TENT ASSEMBLY

4

The mounting extrusion fitted to the base of the tent with slide plate and bolt fitted.

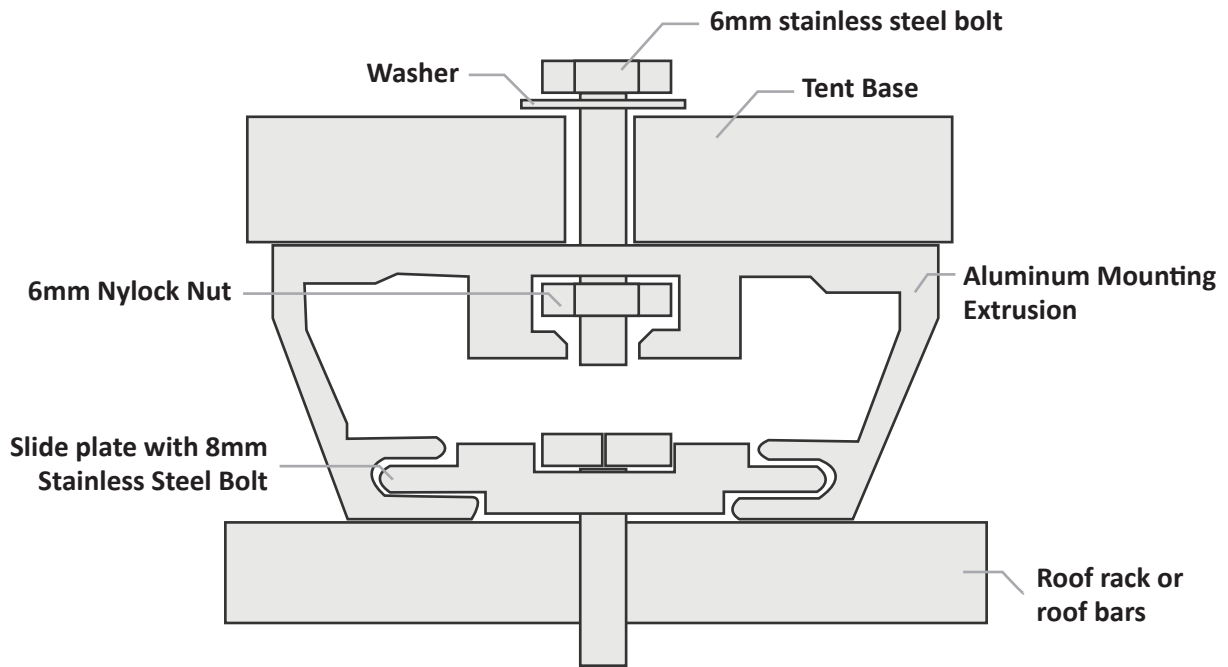

5

Attach the brackets to the ladder by threading the shorter bolt through a steel washer, the lateral side of the ladder bracet, the rubber washer, and the hole in the ladder, followed by a nylcok nut.

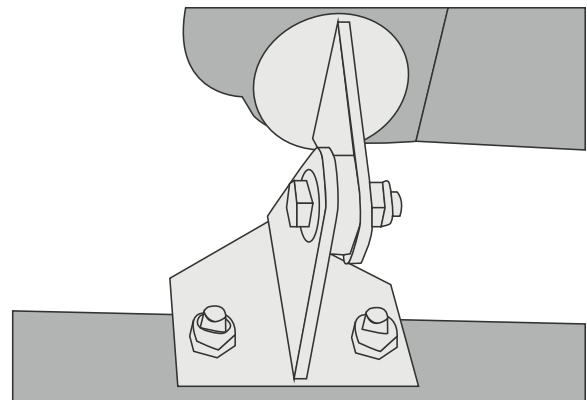

COVER ATTACHMENT

6

To attach the travel cover, slide the rounded fabric end of the cover into the rounded C-Channel at the hinge side of the tent base. Make sure the cover is oriented, so the exterior side of the cover faces up when you pull the cover over the tent

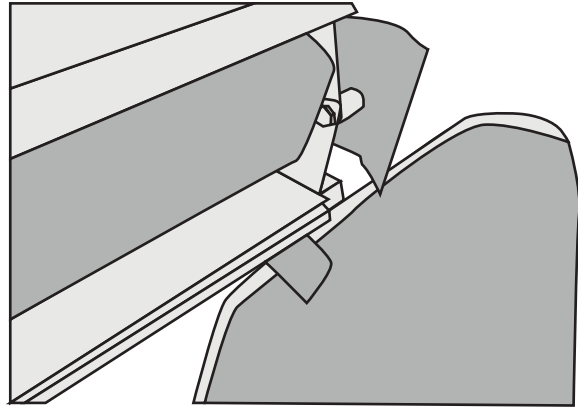

Fasten the Velcro Straps on either side of the tent to hold the canopy in place

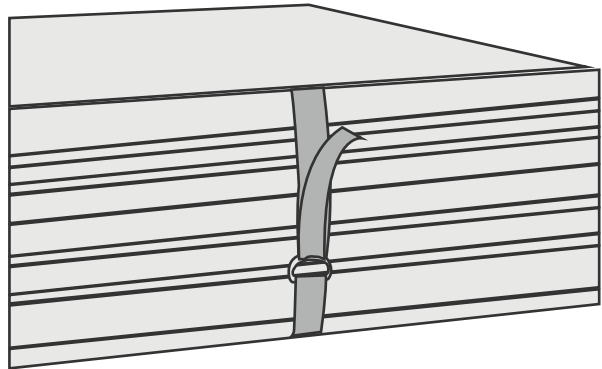

Zip the travel cover to the base along the other three edges, taking care that the tent fabric does not become caught in the zipper. Secure the two long Velcro straps over the top of the travel cover.

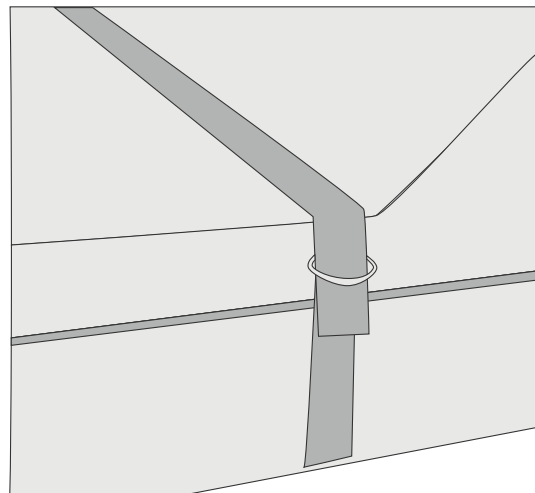
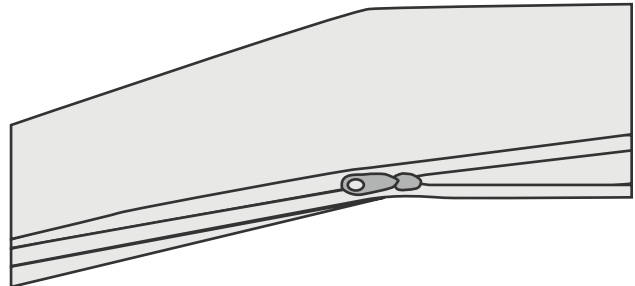

ATTACHMENT TO THE ROOF RACK

7

Place the tent on top of your vehicle rack system, ensuring the mounting tracks are perpendicular to the bars they will mount to, and the tent is centered on the roof rack.

Position the hinge so that the tent will open to the desired side

Slide the 13mm bolts and channel sliders into the mounting tracks. Lift one side of the tent to position one set of bolts and channel sliders on the inner side of the roof rack bar and an additional set on the opposite side. Repeat on all four corners.

At each of the four corners where the rack bars and mounting tracks cross, using a steel mounting plate and nylock nuts to secure the bolts on either side of the bar. Tighten all eight bolts securely with the included nuts and wrench. Check all the mounting bolts and brackets periodically during use.

After ensuring the tent is positioned correctly and all eight bolts are tightened securely, insert rubber end caps into the ends of the mounting tracks. This may require light taps from a hammer.

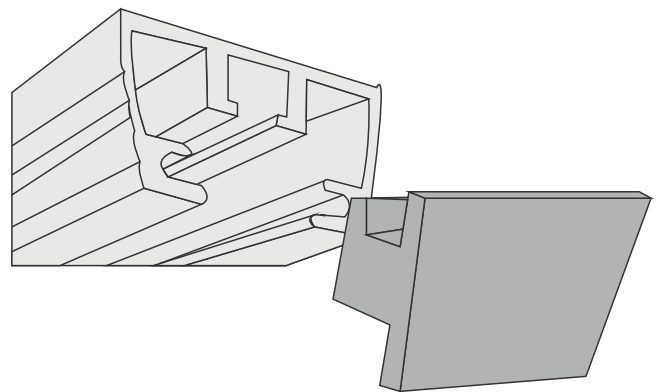
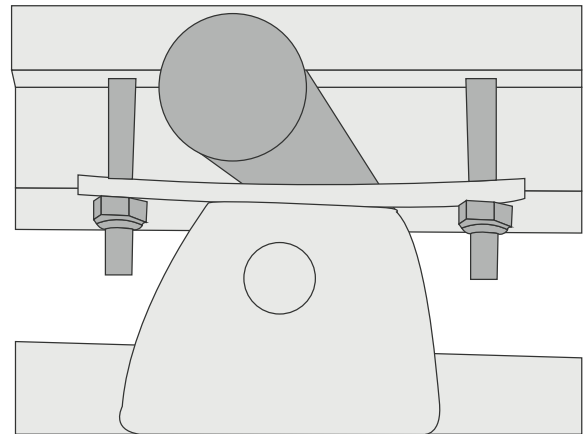
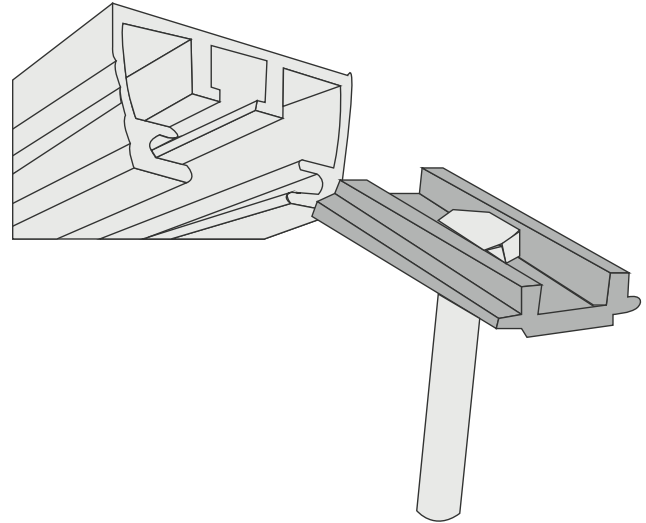

TENT SET UP

8

Release the straps over the travel cover

Unzip the travel cover. You can remove it, roll it up, or let it hang off the side of your vehicle

Unbuckle the straps on the sides of the tent and across the ladder

Use the ladder as leverage to open the tent by pulling straight back until the ladder rests firmly on the ground. Assure all the steps on the telescoping ladder are locked. The tent base should be level and the ladder should form a 60° angle with the ground.

To adjust the ladder height, pull on the locking pins in front of ladder and adjust to the desired height. Make sure the pins lock at the desired height.

Unfasten the grommets on the awning and rainfly. Locate the fabric slits in the tent skirt. Pre-drilled holes are located underneath each slit. Insert the rainfly rod at a 45° angle into the hole and bend slightly to hook the other end through the grommet. Repeat this process for both holes in the awnings and both holes at either end of the rainfly.

To close the tent, remove the rainfly rods. Extend the ladder, using it as leverage to close the tent. To collapse the ladder, press the red buttons at the base of the ladder. Fasten the straps at the sides of the tent and across the ladder before zipping on the cover. Secure with the Velcro Straps that run across the cover

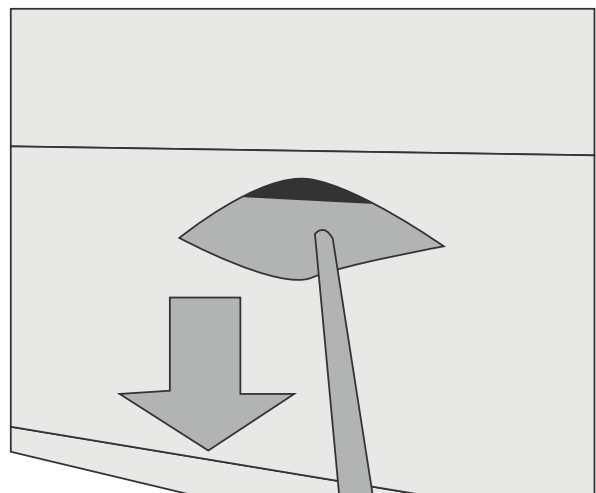
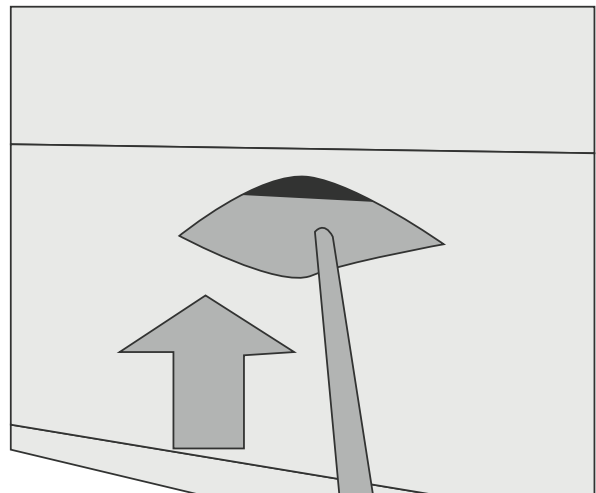

Nomadic Standard Roof Top Tent

SET-UP & CARE INSTRUCTIONS

FEBRUARY 2024

CLEANING

1. Open the tent fully and brush / vacuum inside.
2. Clean the fabric as needed using a mild detergent, warm water, and a soft to medium brush. Rinse fabric of all detergent prior to drying.
3. Dry tent in the sun with all windows open. The tent must be completely dry before storage, or mildew and mold may occur. This is especially necessary after camping in rain or wet conditions.
4. Using a small brush, remove dirt from zippers. Use a silicon spray to keep zippers lubricated.
5. Wash mattress pad and hang dry

STORING

1. Clean and dry the tent
2. Store in a cool, dry place



WARNINGS

- **THE NOMADIC STANDARD ROOF TOP TENT HAS BEEN DESIGNED FOR GENERAL CAMPING USE UNDER NORMAL CONDITIONS.**
- **TO AVOID CHANCES OF PERSONAL INJURY AND PROPERTY DAMAGE, WE HIGHLY RECOMMEND THE NOMADIC STANDARD ROOF TOP TENT SHOULD NOT BE ERECTED DURING WINDY CONDITIONS AS PERSONAL INJURY AND OR PROPERTY DAMAGE MAY OCCUR.**
- **DO NOT CUT OR MODIFY THE TENT OR MOUNTING ACCESSORIES.**
- **DO NOT EXCEED THE VEHICLE MANUFACTURER'S WEIGHT LIMITS.**
- **DO NOT USE DAMAGED OR EXCESSIVELY WORN PRODUCTS. CONTACT US IF YOU ARE UNSURE.**
- **KEEP ALL FLAMES AND HEAT SOURCES AWAY FROM THE FABRIC**
- **UNDER NO CIRCUMSTANCES SHOULD ANY NAKED FLAME SOURCES BE USED NEAR THE TENT, KEEP FIRES AWAY FROM THE TENT**
- **KEEP A LOOK OUT FOR ANY AIRBORNE BURNING EMBERS THAT MAY COME IN CONTACT WITH THE TENT. KEEP A FIRE EXTINGUISHER OR BUCKET OF WATER NEAR BY.**
- **DO NOT OPERATE ANY DEVICES WHICH BURN FUEL INSIDE THE TENT WHILE THE WALLS ARE ATTACHED.**
- **KEEP EXITS CLEAR**
- **KEEP AN EYE OUT FOR CHILDREN WHEN TENT IS IN USE**
- **STOW AWAY TENT BEFORE OPERATING VEHICLE**



DO YOU NEED OUR HELP?



CUSTOMER SUPPORT 833-226-4863



SALES@OVERLANDVEHICLESYSTEMS.COM

WANT TO SHOW US YOUR RIG?
CHECK OUT OUR SOCIAL!

@overlandvehiclesystems

