

Sensor Activated Clean Dry® Hand Dryer

FEATURES

- Hygienic sensor-activated hand dryer
- Double-sided blowers for faster dry time
- Sleek and compact design
- 208 mph of air speed
- Side panels and water tray to prevent water from trickling to the floor
- Low operating noise - 57dB(A)
- Energy efficient

COLORS/FINISHES

- #WH White

CODES/STANDARDS

- Meets or exceeds ANSI/UL 507, 9th edition, Rev. June 18th 2012 and CSA C22.2 No. 113-12 Oct 2012.
- Certifications: Intertek/ETL



PRODUCT SPECIFICATION

TOTO Model No. HDR120#WH shall be a sensor activated hand dryer. Product shall have double-sided blowers with 208mph of air speed. Product shall have the decibel rating of 57dB(A) and power rating of 690 W.



HDR120#WH

Sensor Activated Clean Dry® Hand Dryer

SPECIFICATIONS

- Warranty One Year Warranty
- Power Connection Hardwired
- Power Rating 120V AC, 5.75 Amps, 60 Hz, 690 W
- Power Saving Function Automatically turns OFF when hands are removed or after 30 seconds of use
- Air Speed 208mph
- Water Tray Capacity 0.25gal (950ml)
- Unit Size 11 13/16" x 7 3/8" x 21 5/8"
- Unit Weight 16.1lb (7.3kg)
- Operating Temperature 32°-104°F (0°-40°C)
- Shipping Size 25-5/8" x 14-31/32" x 10-15/16" (650mm x 380mm x 277mm)
- Shipping Weight 21.4lb (9.7kg)

These dimensions and specifications are subject to change without notice.

INSTALLATION NOTES

For ADA installation, refer to codes. See the template for locating the installation of the mounting bracket.

ROUGH-IN

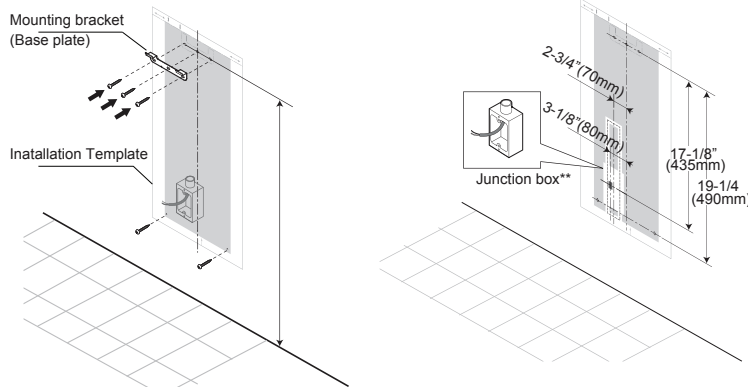

Recommended mounting bracket heights from floor are as follows:

General users: 35" [890mm]
 Children: 26-1/8" [665mm]
 ADA: 34" [865] **

**For ADA installation, refer to codes.

**Does not include junction box

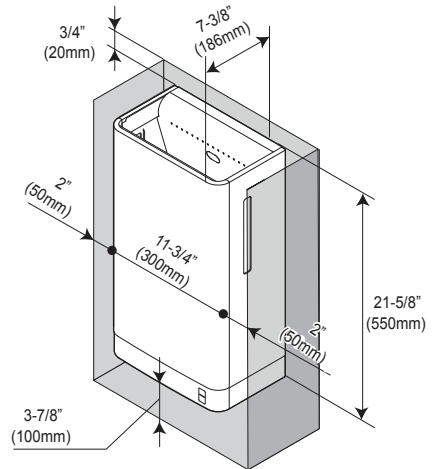

***Clearance is required in order to take the water tray side covers for cleaning and maintenance.