

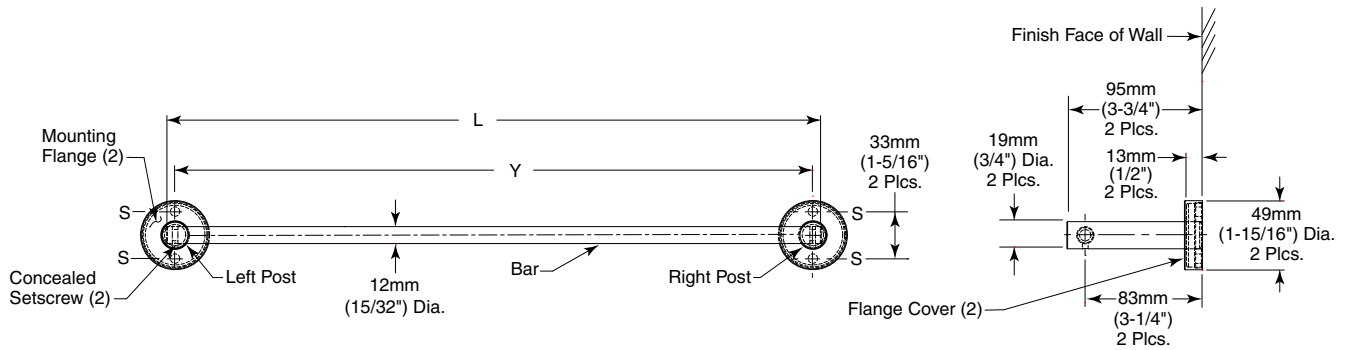

# Technical Data

# TOWEL BAR

# B-545



### STANDARD STOCK SIZES

Model No.	Bar Length L	Centerline-to-Centerline Y
B-545 x 18	460mm (18")	450mm (17-5/8")
B-545 x 24	610mm (24")	600mm (23-5/8")

### MATERIALS:

**Post** — 18-8, type-304, 19mm (3/4") diameter, solid stainless steel rod with satin finish. Post and Concealed Mounting Flange are machined as one piece.

**Bar** — 18-8, type-304, 12mm (15/32") diameter, solid stainless steel rod with satin finish. Secured to Posts with two (2) concealed set screws.

**Concealed Mounting Threaded Flange** — 18-8, type-304, 6mm (7/32") thick, stainless steel plate with thread on outside edge for fastening cover. 46mm (1-13/16") outside diameter with two holes for attachment to wall.

**Threaded Flange Cover** — 18-8, type-304, 1mm (17-gauge), machined stainless steel with satin finish. 49mm (1-15/16") diameter 13mm (1/2") deep. Cover fastens over mounting flange to conceal mounting screws.

### INSTALLATION:

For plaster or dry wall construction, provide concealed backing to comply with local building codes, then secure unit with sheet-metal screws (not furnished). For other wall surfaces, provide fiber plugs or expansion shields for use with sheet-metal screws (not furnished), or provide 3mm (1/8") toggle bolts or expansion bolts. For partitions with particle-board or other solid core, secure with sheet-metal screws (not furnished), or provide through-bolts, nuts, and washers. For hollow-core metal partitions, provides a solid backing into which the sheet-metal screws (not furnished) can be secured. NOTE: centerline-to-centerline of mounting flanges must be within 2mm (1/16") of the Y dimension given.

### SPECIFICATION:

Towel bar shall be type-304 stainless steel with satin finish. Towel bar shall have two (2) 19mm (3/4") diameter posts. Bar shall be 12mm (15/32") diameter secured to post with two (2) concealed set screws. Concealed mounting flange shall be 6mm (7/32") thick stainless steel plate, 46mm (1-13/16") outside diameter and equipped with two screw holes for attachment and thread on outside edge to fasten cover. Threaded flange cover shall be 1mm (17-gauge) stainless steel, 49mm (1-15/16") diameter and shall fasten over mounting flange to conceal mounting screws. Post and mounting flange are to be machined as one piece.

**Towel Bar shall be Model B-545 of Bobrick Washroom Equipment, Inc., Clifton Park, New York; Jackson, Tennessee; Los Angeles, California; Bobrick Washroom Equipment Company, Scarborough, Ontario; Bobrick Washroom Equipment Pty. Ltd., Australia; and Bobrick Washroom Equipment Limited, United Kingdom.**

