



**AMERICAN SPECIALTIES, INC.**

441 Saw Mill River Road, Yonkers, NY 10701 (914) 476-9000  
www.americanspecialties.com

MODEL No: 94696AC

ISSUED: 01-08

REVISED: 03-08

**RECESSED AUTOMATIC ROLL PAPER TOWEL DISPENSER AND WASTE RECEPACLE**

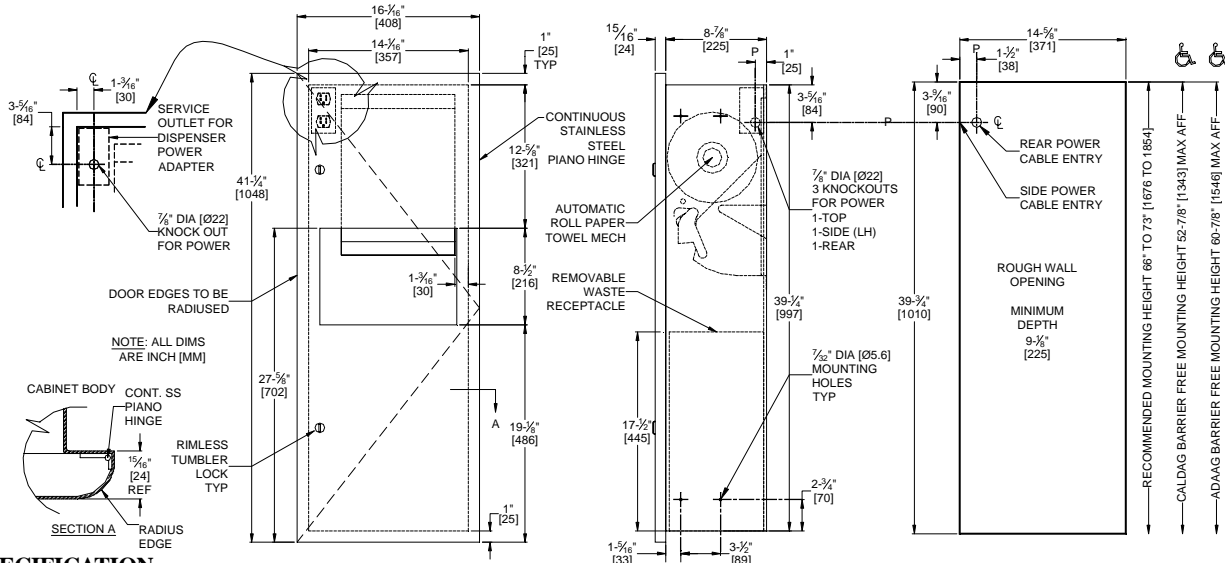

**SPECIFICATION**

Recessed Automatic Roll Paper Towel Dispenser and Waste Receptacle shall hold and dispense one 8" diameter (Ø203) x 8" wide (203) standard towel roll up to 800 ft. (244m) long and one 8" wide (203) stub roll up to 4" diameter (Ø102) and shall have a waste capacity of 10 gallons (38 liters). An automatically operated dispensing mechanism shall be supplied. Dispenser shall be powered by C-UL-US and CE approved internal low-voltage adapter (supplied) using 110-240VAC, 50/60 Hz and providing output of 5VDC @ 1A and shall operate automatically to activate towel dispensing when hands are placed in sensor zone. Unit shall feed out a 12" (305) length of paper towel during each activation and shall have an internal tear-off bar for towel pull out. Towel dispensing opening shall have a fully deburred edge for snag free dispensing and user safety. Full-face door, cabinet, dispenser and waste receptacle shall be fabricated of type 304 stainless steel alloy 18-8. All exposed surfaces shall have a N<sup>o</sup>4 satin finish and shall be protected during shipment with PVC film easily removable after installation. Cabinet and frame shall be fabricated of 20 gauge type 304 stainless steel alloy 18-8 with 1" (25.4) wide perimeter trim to lay flat against wall. Full-face door shall be 16 gauge and shall be free of miters, welding or open seams with 3/4" (19) radiused vertical edges and 15/16" (24) square horizontal returns to wall. Door shall be attached to the edge of unit with a concealed full length 3/16" diameter (Ø4.8) heavy duty stainless steel multi-staked piano hinge and shall be held closed with two (2) flush rimless tumbler locks keyed alike to other ASI washroom equipment. Unit back plate for mechanism shall be fabricated of 18 gauge. Interior waste receptacle shall be fabricated of stainless steel and shall have a welded on finger pull for ease of service removal and maintenance safety. Structural assembly of all components shall be of welded construction.

**Recess Mounted Automatic Roll Paper Towel Dispenser and Waste receptacle shall be Model N<sup>o</sup> 94696AC as manufactured by American Specialties, Inc., 441 Saw Mill River Road, Yonkers, New York 10701-4913**

**INSTALLATION**

Install unit in wall recess with four (4) N<sup>o</sup>10 self-tapping screws (by others) through concealed mounting holes provided. Note that top of Rough Wall Opening (RWO) is 3/4" (19) below top of unit. For compliance with ICC/ANSI A-117.1-2003 and ADA Accessibility Guidelines, install unit so that top edge of towel dispenser opening is 48" (1219) maximum above finished floor (MAX AFF) only if clear floor forward reach or side reach access is provided. Be advised that local codes may require mounting so that top of towel dispenser opening is 40" (1016) MAX AFF (e.g. California UBC/Title 24). For general utility install unit with centerline of towel dispenser opening between 49" and 56" (1245 to 1422) AFF. Power is supplied by code approved cable or conduit (by others) to RWO at any one of three [3] available locations indicated on diagram and terminated in utility simplex outlet box (provided) inside cabinet. Power required is 110-240VAC at 50/60 Hz protected by a 15A circuit breaker (by others) for low voltage adapter that draws ¼ Amp. Power adapter for dispenser unit is supplied cabled and plugged into dispenser and is plugged into simplex outlet (by others).

**RWO required is 14-5/8" W x 39-3/4" H x 9-1/8" D (371 x 1010 x 232)**

**OPERATION**

Towels are dispensed one at a time automatically when hands are placed in sensor zone until supply is depleted. Unit may be reloaded with a full roll to automatically start when finished with an existing partial roll and will continue to feed properly when reloaded with a full roll and partial roll is transferred to stub roll position. Refill dispenser by unlocking door and replacing towel roll for an empty or partially empty unit. Dispenser supply is replenished and waste container is emptied manually on cycles determined by maintenance needs. Locking full-face door over compartments prevents unauthorized access or removal.

Accessory Specialties

AMERICAN DISPENSER

Desert Ray Products

WATROUS INC.