



AMERICAN SPECIALTIES, INC.

441 Saw Mill River Road, Yonkers, NY 10701 (914) 476-9000

MODEL No: **6474**

ISSUED: 1-87

REVISED: 9-04

RECESSED WASTE RECEPTACLE

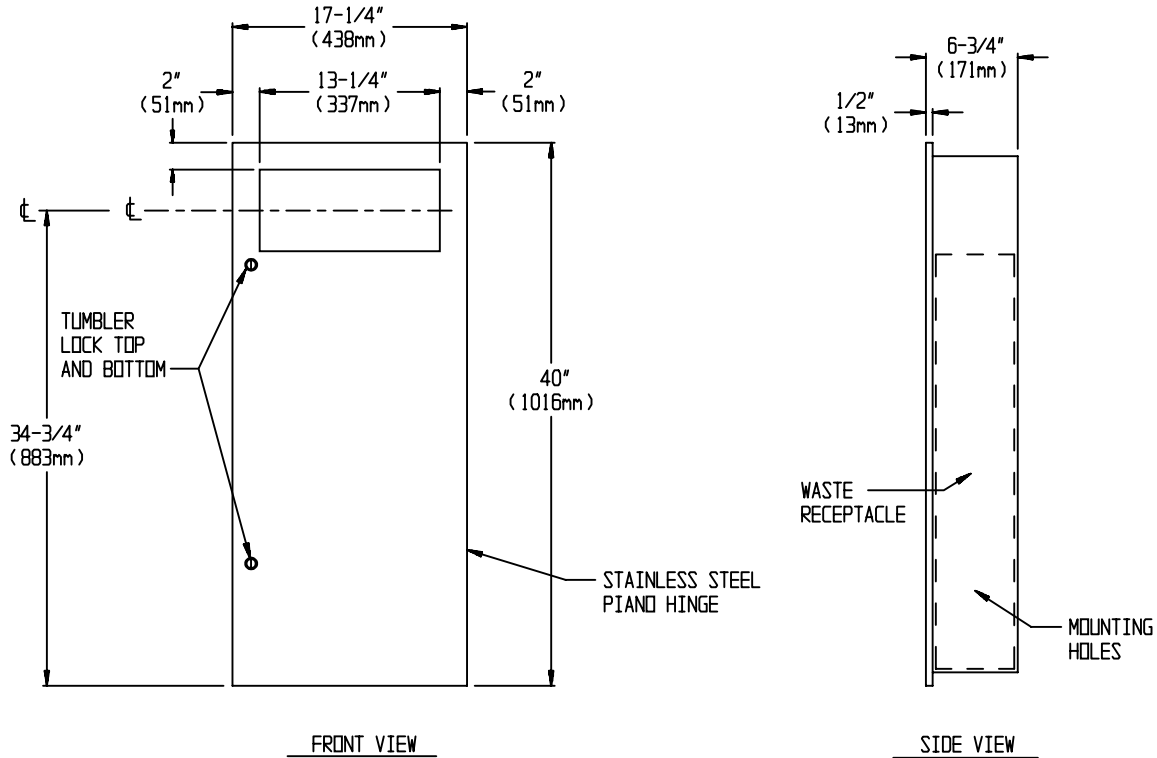

SPECIFICATION

Recessed Waste Receptacle unit shall have a waste capacity of 12 gal (46liters) and shall be fabricated of alloy 18-8 stainless steel, type 304. Full face door shall be fabricated from one piece of 18 gauge and shall be free of miters, welding or open seams on face and shall have a 1/2" (13mm) square return to wall and shall be attached to the edge of unit with a full length 3/16" (5mm) dia. stainless steel multi-staked piano hinge and shall be held closed with two (2) tumbler locks keyed alike to other ASI washroom equipment. Cabinet shall be fabricated from 20 gauge and shall have a 1" (25mm) wide perimeter trim to lay flat against wall. Waste container shall be fabricated of heavy duty stainless steel with a finger grip for easy removal. All exposed surfaces shall have a N° 4 satin finish and shall be protected during shipment with a PVC film that shall be easily removable after installation.

Recessed Waste Receptacle Unit shall be Model N° 6474 as manufactured by American Specialties, Inc., 441 Saw Mill River Road, Yonkers, New York 10701- 4913

INSTALLATION

Unit is mounted in wall recess using N° 10 self tapping screws (by others) through concealed mounting holes provided. For compliance with ADA Accessibility Guidelines the unit should be installed so that the center of the waste receptacle opening is 54" (1372mm) max. above finished floor (AFF) when clear floor side reach access is provided or 48" (1168mm) max. AFF if clear floor forward reach access is only provided.

Rough Wall Opening (RWO) required is.... 15-3/4"W x 38-1/2"H x 6-1/4"D minimum (400mm x 978mm x 159mm)

OPERATION

Waste is inserted through opening at upper section of unit. Waste container is emptied manually on cycle determined by maintenance needs. Locked door prevents unauthorized access or removal.

Accessory Specialties

AMERICAN DISPENSER

Desert Ray Products

WATROUS inc.