

Model 5410339 Horizontal Diaper Changing Station

Recommended Blocking

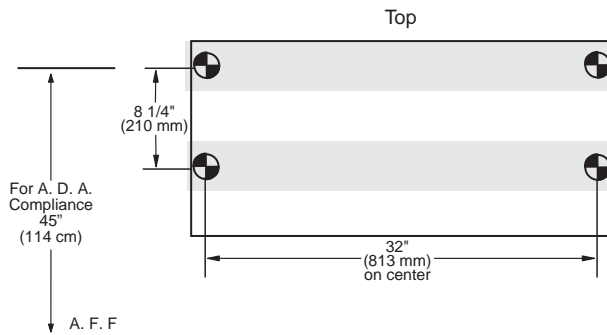

Short Specifications

Polyethylene Diaper Changing Stations with Stainless Steel Exterior:

1. Acceptable product: Foundations Worldwide, Inc.; Model 5410339
2. Characteristics:
 - a. Type: Molded FDA approved high-density polyethylene (HDPE) body.
 - b. Child protection strap featuring cam-buckle which is adjustable with one hand.
 - c. Smooth nylon safety belt is easily cleaned.
 - d. Warning labels printed in English, Spanish and French.
 - e. Meets ASTM F2285 requirements for weight bearing Commercial Changing Stations.
 - f. Entire body 18 gauge, 304 brushed stainless steel.
3. A.D.A. Compliance:

	306.3 Knee Clearance
	307.2 Maximum Protruding Objects
	308.2 Forward Reach
	308.3 Side Reach
	309.4 Operation
	902.3 Work Surface

Compliant when properly installed.
4. ANSI compliant safety labels.
5. CPSIA compliant to applicable sections.

- Polyethylene body with stainless steel exterior.
- Easy to clean, high-density polyethylene which is naturally bacteria resistant ; beneath 304 brushed stainless steel encasement.
- Standard with molded-in dual liner dispensers.
- Each liner dispenser holds approximately 50 of the 036-LCR or 036-NWL liners.
- A.D.A. cam-buckle is adjustable with one hand.
- Smooth nylon safety belt is easily cleaned and does not harbor bacteria.
- Convenient bag hooks clearly labeled on both sides.
- Easy to read ANSI compliant labels (ANSI Z535.3 and ANSI Z535.4), utilizing universal safety symbols.
- Compact, slim profile meets A.D.A. Only protrudes 4 inches or 102 mm from wall.
- Includes universal changing station door sign.
- Pneumatic gas shock mechanism to ensure smooth, safe open and close motions.
- Steel-to-steel support hinges.
- Includes easy to install, step-by-step instructions plus all mounting hardware.
- ASTM G21 Anti-Bacterial: No measurable bacterial growth.
- ASTM G22 Anti-Fungal: No measurable fungal growth.
- Meets or exceeds ASTM F2285 Safety Specifications for Commercial Changing Stations.
- Standard pack: 1 unit.
- Limited Warranty: This product is warranted against manufacturing defects for a period of 5 years.

Installation Information

- Closed unit projects less than 4 inches (101 mm) from wall.
- Open changing surface projects 17 inches (445 mm) from wall during use.
- Overall closed dimensions are 34-5/8 inches (870 mm) wide and 17 inches (390 mm) tall.
- Hardware allows for mounting to current or new construction applications.