

Submittal Sheet

Model 5240259 Polyethylene Horizontal Recessed Diaper Changing Station

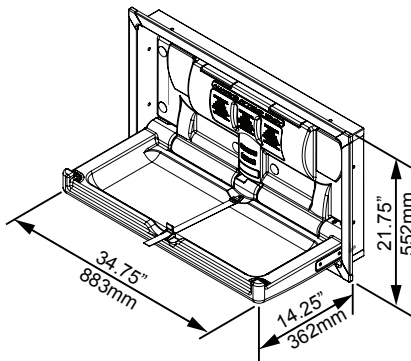

Recommended Blocking Recessed Mount

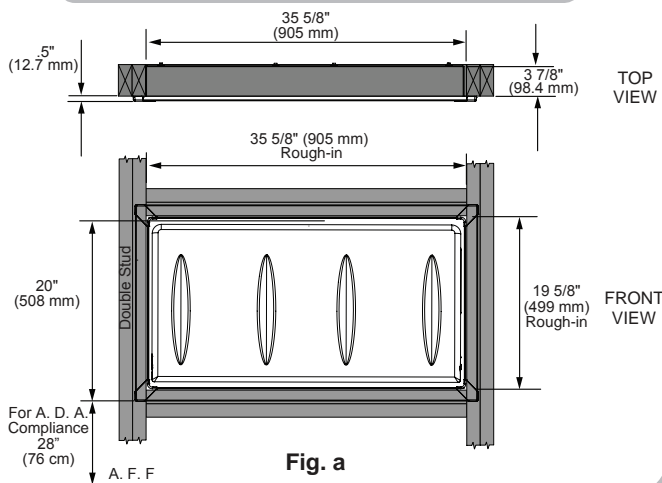

Fig. a

Installation Information

- 3-7/8 inches (98.4mm) recessed into wall, 1 inch (25 mm) protrusion from wall.
- Rough-in opening 35.625 inches (905 mm) wide x 19.625 (499 mm) high. Shim as required for tight fit on all 4 sides. For recess mount, use side mounting holes.
- Open unit project from wall 14-1/4 inches (362 mm) when recessed.
- 3.5 inches (89 mm), 18 gauge metal studs minimum. Line studs with trimmed 2 x 4's.

- Polyethylene body with stainless steel exterior.
- Easy to clean, high-density polyethylene which is naturally bacteria resistant; beneath 304 brushed stainless steel encasement.
- Standard with molded-in dual liner dispensers.
- Each liner dispenser holds approximately 50 of the 036-LCR or 036-NWL liners.
- A.D.A. cam-buckle is adjustable with one hand.
- Smooth nylon safety belt is easily cleaned and does not harbor bacteria.
- Convenient bag hooks clearly labeled on both sides
- Easy to read ANSI compliant labels (ANSI Z535.3 and ANSI Z535.4), utilizing universal safety symbols.
- Compact, slim profile meets A.D.A. Only protrudes 4 inches or 102 mm from wall.
- Includes universal changing station door sign.
- Pneumatic gas shock mechanism to ensure smooth, safe open and close motions.
- Includes easy to install, step-by-step instructions plus all mounting hardware.
- ASTM G21 Anti-Bacterial: No measurable bacterial growth.
- ASTM G22 Anti-Fungal: No measurable fungal growth.
- Meets or exceeds ASTM F2285 Safety Specifications for Commercial Changing Stations.
- Standard pack: 1 unit.
- Limited Warranty: This product is warranted against manufacturing defects for a period of 5 years.

Short Specifications

Polyethylene Diaper Changing Stations with Stainless Steel Exterior:

1. Acceptable product: Foundations Worldwide, Inc.; Model 5240259.
2. Characteristics:
 - a. Entire body 16 gauge 304 brushed stainless steel, seamless welds.
 - b. Provide Foundations Worldwide, Inc. 200-SSLD; stainless steel liner dispenser.
3. Equipped with a pneumatic cylinder.
4. Smooth nylon safety belt is easily cleaned.
5. Meets ASTM F2285 requirements for weight bearing changing stations.
6. **A.D.A. Compliance:**
 - 306.3 Knee Clearance
 - 307.2 Maximum Protruding Objects
 - 308.2 Forward Reach
 - 308.3 Reach Side
 - 309.4 Operation
 - 902.3 Work Surface
 Compliant when properly installed.
7. ANSI compliant safety labels.
8. CPSIA compliant to applicable sections.

