

**For Installation of Grab Bar Through Toilet Partition Panel.
One Anchor Required for Each Flange.**

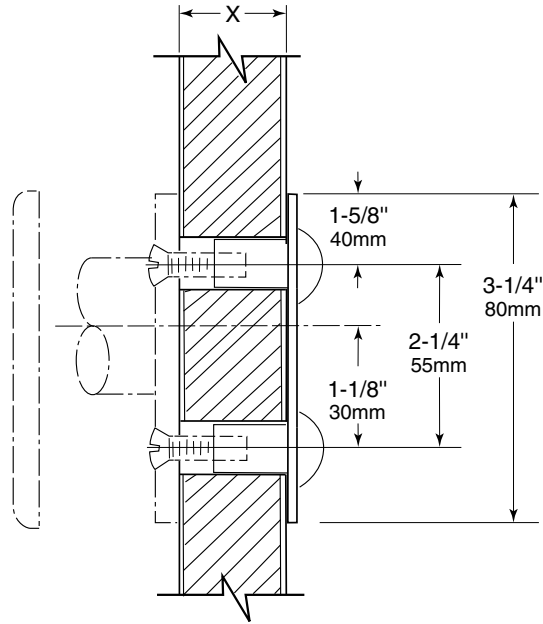

For B-530, B-490 and B-6106 Series Grab Bars

Anchor No.	Partition Thickness X
2583	3/4" to 1" 19 to 25mm
2586	1/2" 13mm

MATERIALS:

Backplate — 18-8, type-304, 16-gauge (1.6mm) stainless steel with satin-finish.

Screws — For 2586 Anchor - (2) Part No. 2584-6 Screw (1/4 - 20 x 1/2" Phillips Round Stainless Steel Machine Screw)
For 2583 Anchor - (2) Part No. 2582-3 Screw (1/4 - 20 x 3/4" Phillips Pan Head Stainless Steel Machine Screw)

Nuts — For 2586 Anchor - (2) Part No. 2584-104 Nut (Chrome Plated Brass, Sphere Head 1/2" Nut)
For 2583 Anchor - (2) Part No. 258-104 Nut (Chrome Plated Brass, Sphere Head 3/4" Nut)

INSTALLATION:

Using grab bar as a template, mark toilet partition panel. Drill 7/16" (11mm) holes for connectors. Insert connectors through backplate and into holes in panel. Secure grab bar to connectors using screws furnished by manufacturer.

SPECIFICATION:

Grab bar anchors shall have type-304, 16-gauge (1.6mm), satin-finish stainless steel backplate. Threaded chrome-plated brass connectors shall be keyed to backplates to prevent rotation. Stainless steel machine screws shall be furnished by manufacturer.

Grab Bar Anchors shall be Anchor No. _____ (insert anchor number) of Bobrick Washroom Equipment, Inc., Clifton Park, New York; Jackson, Tennessee; Los Angeles, California; Bobrick Washroom Equipment Company, Scarborough, Ontario; Bobrick Washroom Equipment Pty. Ltd., Australia; and Bobrick Washroom Equipment Limited, United Kingdom.

