

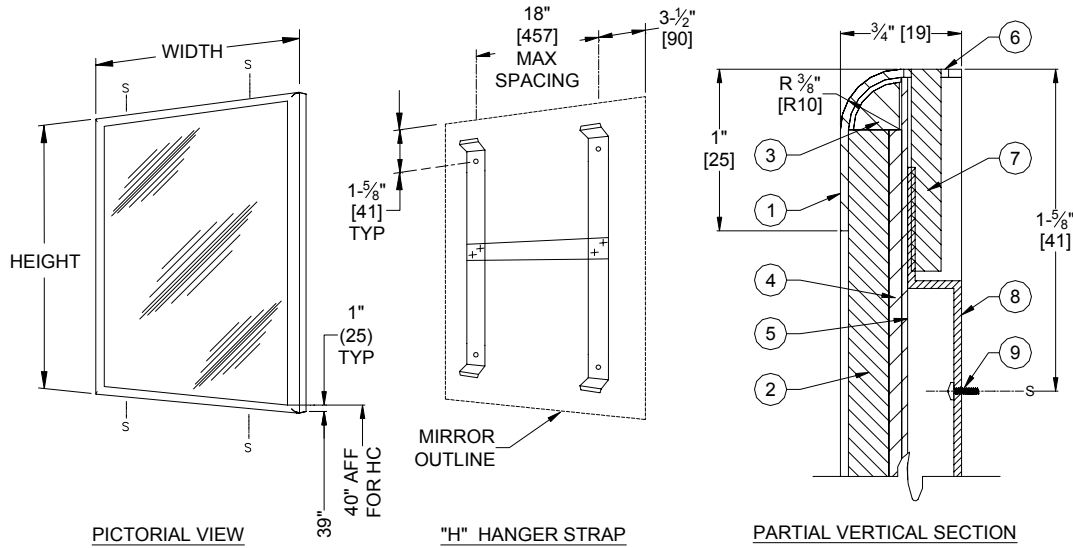

AMERICAN SPECIALTIES, INC.
441 Saw Mill River Road, NY 10701 (914) 476-9000
www.americanspecialties.com

MODEL №: 20650
ISSUED: 09/09
REVISED:

ROVAL™ INTER-LOK STAINLESS STEEL FRAMED MIRROR



| WIDTH | STRAP SPACING | # HANGER STRAPS |
|-----------|---------------|-----------------|
| 18" [457] | 11" [279] | 2 |
| 24" [610] | 17" [432] | 2 |
| 36" [914] | 14-1/2" [368] | 3 |

DESCRIPTION

- 18 GAUGE STAINLESS STEEL FRAME
- 1/4" (6) PLATE GLASS MIRROR
- SHOCK ABSORBING EDGE CUSHION
- NON-ABSORBENT FILLER
- 20 GAUGE CORROSION PROTECTED STEEL BACK
- MOUNTING FLUSH NUTSERT
- TAMPERPROOF MOUNTING & LOCKING HEX SOCKET HEADLESS SET-SCREW #10-32 X 1-1/4"(32)
- HANGER BRACKET 18 GAUGE
- INSTALLATION SCREW-FURNISHED BY INSTALLER

SPECIFICATION

Roval™ Collection Inter-Lok Stainless Steel Framed Mirror shall have frame fabricated of 18 gauge type 304 stainless steel alloy 18-8. Frame full front shall be formed seamless with mitered corners welded and polished and shall have gently radiused edges to provide added strength and complimentary appearance for modern washroom aesthetics. All exposed surfaces shall be satin finish. Mirror glazing shall be _____ (insert glazing option) and shall be warranted for 15 years against silver spoilage. All edges of mirror shall be protected with friction and chafe absorbing fillers. Full size shock-absorbing water-resistant filler and full size one-piece 20 gauge corrosion protected steel shall protect back of mirror. An 18 gauge corrosion protected steel 'H' bracket shall be supplied with all required mounting hardware. Mirror shall be secured to vertical bracket with hex socket headless locking screws.

Roval™ Collection Inter-Lok Stainless Steel Framed Mirror shall be Model № 20650- ____ (insert glazing option) of American Specialties, Inc., 441 Saw Mill River Road, Yonkers, New York 10701-4913

MATERIALS

- Frame: 18 gauge type 304 stainless steel alloy 18-8, (.048" <1.2> thick). Unitized all welded construction. Exposed surfaces have satin finish. Edges and corners are burr free.
- Glass: Standard glazing is № 1 quality, 1/4" (6.4) thick plate/float glass, silver coated and hermetically sealed with a uniform coating of electrolytic copper plating and warranted against silver spoilage for 15 years. Mirrors meet Federal Spec DD-M-411C, ASTM C-1036-06, ASTM C-1048-92, ASTM C-1503-01.
- Filler: Expanded polyethylene microcell foam sheet material, abrasion resistant and shock absorbing, water resistant, 1/8" (3.2) total layer thickness.

INSTALLATION

Install bracket level and plumb as per diagram location using № 10 x 1" (M5 x 25) self-tapping pan head screws (by others). Hang mirror on bracket and tighten locking screws at top & bottom. For compliance with ADA Accessibility Guidelines bottom edge of reflecting surface should be no higher than 40" (1016) above finished floor.

GLAZING OPTIONS

Units are supplied with standard A glazing 1/4" (6.4) thick plate glass mirror. Other glazing option available is tempered glass mirror 20650-B. For a complete description see the MIRROR GLAZING OPTIONS chart.