

Submittal Sheet

Model 100-EH Horizontal Diaper Changing Station

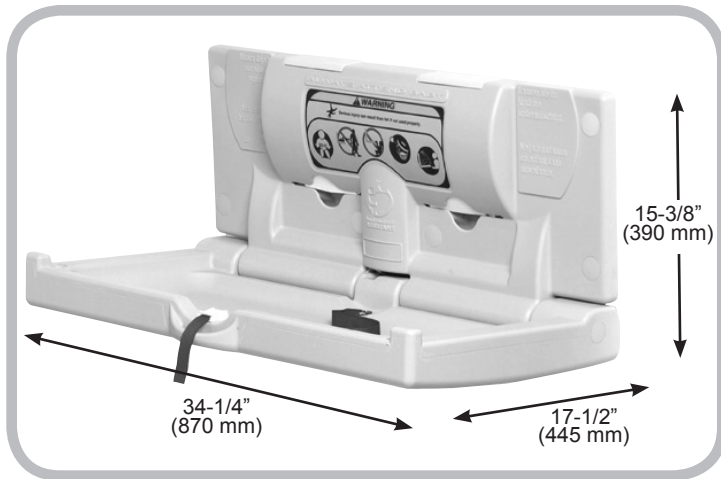

Recommended Blocking

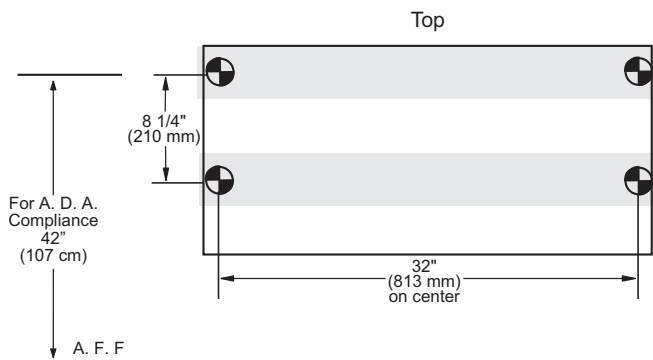

Short Specifications

- Polyethylene Diaper Changing Stations:
- Acceptable product: Foundations Worldwide, Inc.; Model 100-EH.
 - Characteristics:
 - Type: Molded FDA approved high-density polyethylene (HDPE) body.
 - Child protection strap featuring cam-buckle which is adjustable with one hand.
 - Smooth nylon safety belt is easily cleaned.
 - Warning labels printed in English, Spanish and French.
 - Meets ASTM F2285 requirements for weight bearing Commercial Changing Stations.
 - A.D.A. Compliance:**

	306.3 Knee Clearance
	307.2 Maximum Protruding Objects
	308.2 Forward Reach
	308.3 Side Reach
	309.4 Operation
	902.3 Work Surface

Compliant when properly installed.
 - ANSI compliant safety labels.
 - CPSIA compliant to applicable sections.

- Easy to clean, high-density polyethylene which is naturally bacteria resistant.
- Standard with molded-in dual liner dispensers.
- Each liner dispenser holds approximately 50 of the 036-LCR or 036-NWL liners.
- A.D.A. cam-buckle is adjustable with one hand.
- Smooth nylon safety belt is easily cleaned and does not harbor bacteria.
- Convenient bag hooks clearly labeled on both sides.
- Easy to read ANSI compliant labels (ANSI Z535.3 and ANSI Z535.4), utilizing universal safety symbols.
- Compact, slim profile meets A.D.A. Only protrudes 4 inches or 102 mm from wall.
- Includes universal changing station door sign.
- Pneumatic gas shock mechanism to ensure smooth, safe open and close motions.
- Steel-to-steel support hinges.
- Includes easy to install, step-by-step instructions plus all mounting hardware.
- ASTM G21 Anti-Bacterial: No measurable bacterial growth.
- ASTM G22 Anti-Fungal: No measurable fungal growth.
- Meets or exceeds ASTM F2285 Safety Specifications for Commercial Changing Stations.
- Standard pack: 1 unit.
- Limited Warranty: This product is warranted against manufacturing defects for a period of 5 years.

Installation Information

- Closed unit projects less than 4 inches (101 mm) from wall.
- Open changing surface projects 17-1/2 inches (445 mm) from wall during use.
- Overall closed dimensions are 34-1/4 inches (870 mm) wide and 15-3/8 inches (390 mm) tall.
- Hardware allows for mounting to current or new construction applications.