



AMERICAN SPECIALTIES, INC.
441 Saw Mill River Road, NY 10701 (914) 476-9000
www.americanspecialties.com

MODEL No: 0795

ISSUED: 01/87

REVISED: 07/09

MOP HOLDER

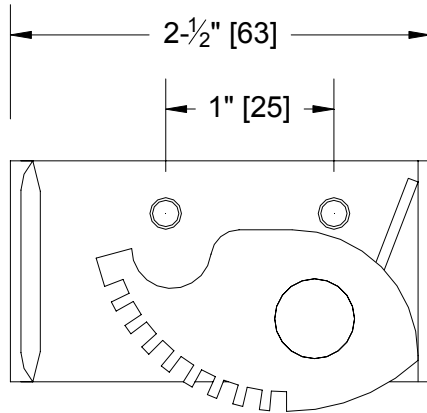

ELEVATION

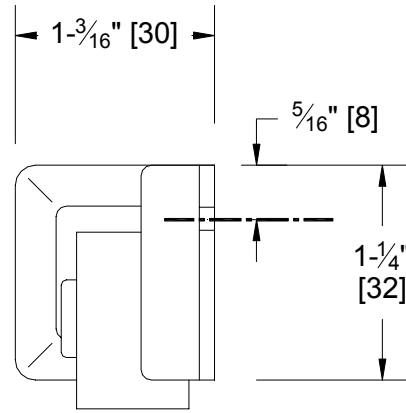

SIDE VIEW

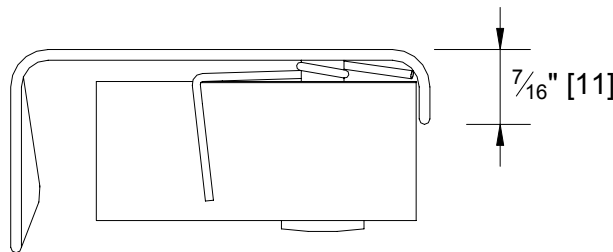

TOP VIEW

NOTE:
ALL DIMS
INCH [MM]

SPECIFICATION

Mop Holder bracket shall be fabricated of cadmium plated steel and be ribbed for rigidity. Pivoting spring loaded serrated rubber cam shall hold round handles of 7/8" to 1-1/4" diameter (Ø22 to 32) wedged against ribbed clamp plate. Unit shall be surface mounted by others.

Mop Holder shall be Model N^o 0795 of American Specialties, Inc., 441 Saw Mill River Road, Yonkers, New York 10701-4913

INSTALLATION

For general utility mount mop holder 70" (1788) AFF (above finished floor) from bottom of mop holder. Secure mop holder to wall with two (2) N^o 10 self-tapping screws (supplied by others) through mounting holes in back plate. For compliance with ADA Accessibility Guidelines, install unit with top of mop holder at 48" (1219) MAX AFF if clear floor access is provided.

OPERATION

Mop or broom handle is pushed into grip-jaw of pivoting serrated rubber cam with upward motion until it seats behind rib on clamp plate. Spring holds cam against handle. Gravity holds mop clamped in position.