



AMERICAN SPECIALTIES, INC.

441 Saw Mill River Road, Yonkers, NY 10701 (914) 476-9000
www.americanspecialties.com

MODEL No: 0625

ISSUED: 1-87

REVISED: 4-06

CHANNEL FRAME MIRROR WITH SHELF

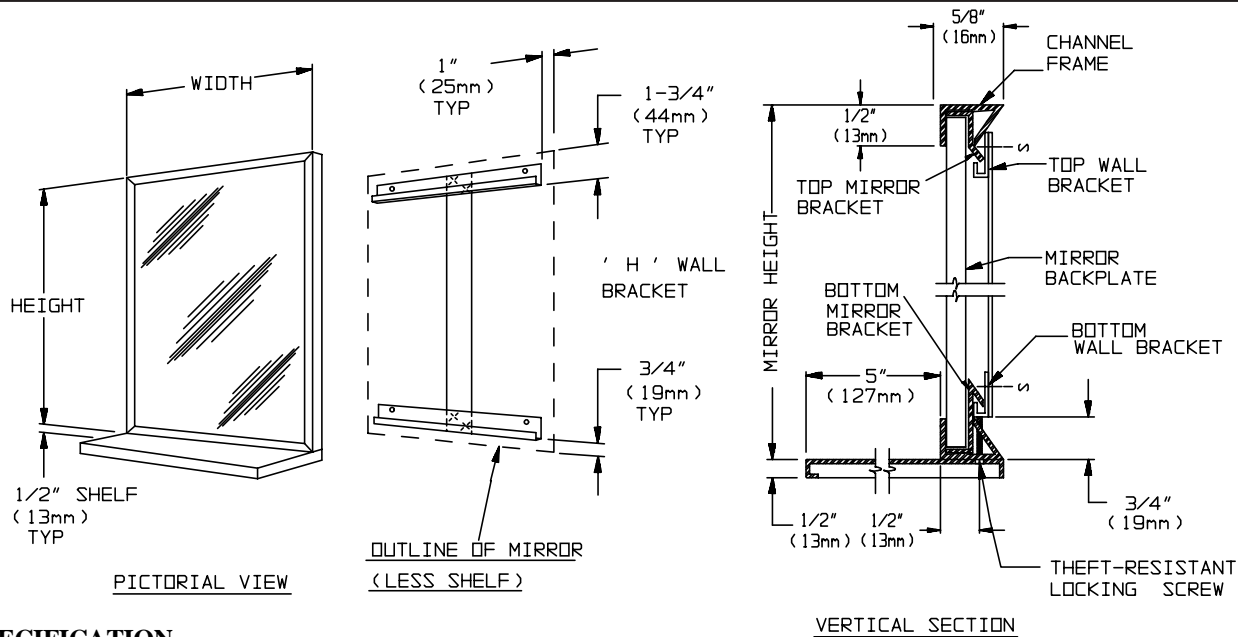

SPECIFICATION

Channel Frame Mirror with Shelf shall have frame fabricated of 20 gauge alloy 18-8 stainless steel, type 304 with mitred corners. Shelf shall be 18 gauge, same grade. Mirror glazing shall be _____ (insert glazing option) and shall be warranted for 15 years against silver spoilage. All edges of mirror shall be protected by friction and chafe absorbing fillers. Back of mirror shall be protected by full size shock-absorbing water-resistant filler and full size one piece 20 gauge corrosion protected steel. Top and bottom wall mounting brackets shall be spot welded into an "H" for easy installation. Mirror shall be secured to lower bracket with a Philips Pan Head locking screw. Finish of unit shall be protected from marring by easily removed self-adhesive PVC film.

Channel Frame Mirror with Shelf shall be Model N° 0625- _____ (insert glazing option)- _____ (note size, W x H) as manufactured by American Specialties, Inc., 441 Saw Mill River Road, Yonkers, New York 10701-4913

MATERIALS

- Frame:** Alloy 18-8, type 304, 20 gauge (.036 in. <.91mm> thick) stainless steel. Unitized all roll-formed one-piece construction. Exposed surfaces have satin finish. Edges and corners are burr free.
- Shelf:** Alloy 18-8, type 304, 18 gauge (.048 in. <1.2mm> thick) stainless steel. Unitized all welded construction. Exposed surfaces have satin finish. Edges and corners are burr free.
- Glass:** Standard glazing is N° 1 quality, 1/4" (6.4mm) thick plate/float glass, silver coated and hermetically sealed with uniform copper plating, and warranted against silver spoilage for 15 years. Mirrors meet Federal Specification DD-M-411C, ASTM C-1036-91.
- Filler:** Expanded polyethylene microcell foam sheet material, abrasion resistant and shock absorbing, water resistant, 1/8" inch (3.2mm) total layer thickness.

FABRICATION NOTE FOR SPECIFICATION

Mirrors larger than 21 sq. ft. (1.95m²) are fabricated in two or more sections to provide installation and handling ease.

INSTALLATION

Install "H" wall brackets level and plumb per diagram location using **ONLY** N° 8 or N° 10 Pan Head screws (by others). Hang mirror on brackets and tighten locking screw (N° 6-32F x 3/4" Philips Pan Head, supplied separately taped to mirror back) at bottom (note: this screw should be started prior to hanging mirror on wall bracket). For compliance with ADA Accessibility Guidelines, bottom edge of reflecting surface should be no higher than 40" (1016mm) above finished floor.

GLAZING OPTIONS

Units are supplied with 1/4" (6.4mm) thick plate glass. Other glazing options are available. For a complete description of any other available glazing, see the **MIRROR GLAZING OPTIONS** chart.

Accessory Specialties

AMERICAN DISPENSER

Desert Ray Products

WATROUS INC.