



**AMERICAN SPECIALTIES, INC.**

441 Saw Mill River Road, Yonkers, NY 10701 (914) 476-9000  
www.americanspecialties.com

MODEL No: 0620

ISSUED: 1-87

REVISED: 4-06

**CHANNEL FRAME MIRROR**

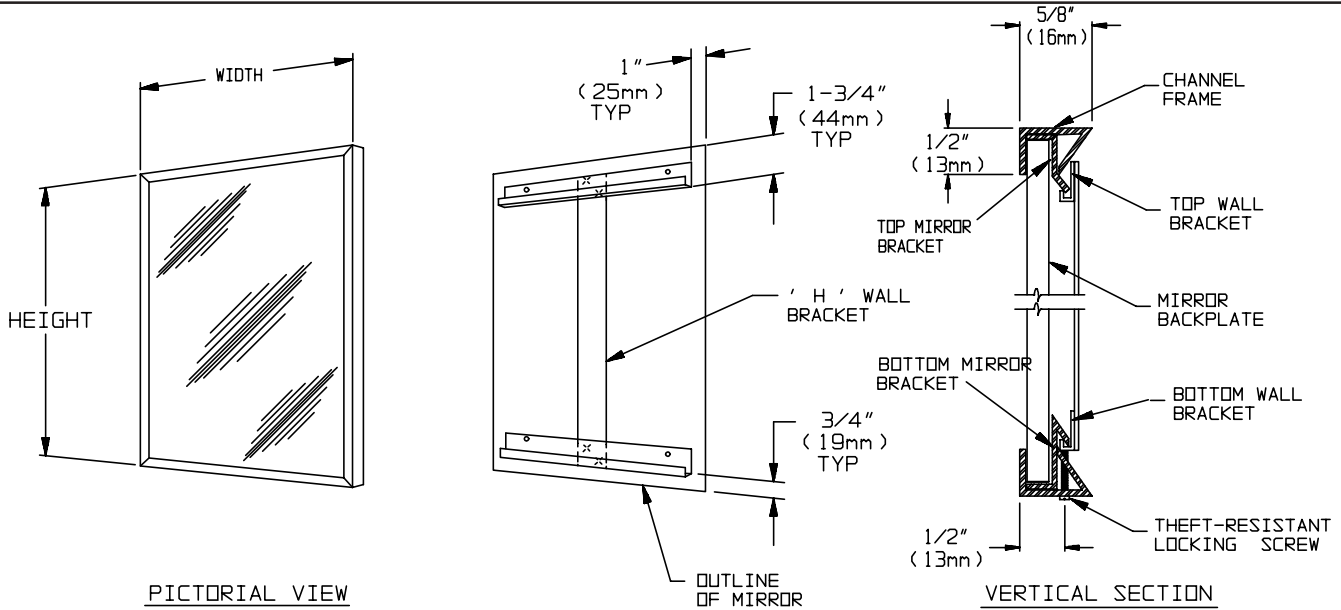

**SPECIFICATION**

Channel Frame Mirror shall have frame fabricated of alloy 18-8 stainless steel, type 304, 20 gauge with mitered corners. Mirror glazing shall be \_\_\_\_ (insert glazing option) and shall be warranted for 15 years against silver spoilage. All edges of mirror shall be protected by friction and chafe absorbing fillers. Back of mirror shall be protected by full size shock-absorbing water-resistant filler and full size one piece 20 gauge corrosion protected steel. Top and bottom wall mounting brackets shall be fabricated of 20 gauge corrosion protected steel and shall be spot welded into "H" hanger. Mirror shall be secured to lower bracket with a Philips Pan Head locking screw.

**Channel Frame Mirror shall be Model N° 0620-\_\_ (insert glazing option)-\_\_ (note size, W x H) as manufactured by American Specialties, Inc., 441 Saw Mill River Road, Yonkers, New York 10701-4913**

**MATERIALS**

**Frame** 18-8, type 304, 20 gauge (.036" <91mm> thick) stainless steel. Unitized all roll-formed one-piece construction. Exposed surfaces have N° 4 satin finish. Edges and corners are burr free.

**Glass:** Standard glazing is N° 1 quality, 1/4" (6.4mm) thick plate/float glass, silver coated and hermetically sealed with uniform copper plating, and warranted against silver spoilage for 15 years. Mirrors meet Federal Specification DD-M-411C, ASTM C1036-91.

**Filler:** Expanded polyethylene microcell foam sheet material, abrasion resistant and shock absorbing, water resistant, 1/8" inch (3.2mm) total layer thickness.

**FABRICATION NOTE FOR SPECIFICATION**

Mirrors larger than 21sq. Ft. (1.95m<sup>2</sup>) are fabricated in two (2) or more sections to provide installation and handling ease.

**INSTALLATION**

Install "H" wall brackets level and plumb per diagram location using **ONLY** N° 8 or N° 10 Pan Head screws (by others). Hang mirror on brackets and tighten locking screw (N° 6-32F x 3/4" Philips Pan Head, supplied separately taped to mirror back) at bottom (note: this screw should be started prior to hanging mirror on wall bracket). For compliance with ADA Accessibility Guidelines, bottom edge of reflecting surface should be no higher than 40" (1016mm) above finished floor.

**GLAZING OPTIONS**

Units are supplied with 1/4" (6.4mm) thick plate glass. Other glazing options are available. For a complete description of any other available glazing, see the **MIRROR GLAZING OPTIONS** chart.