



AMERICAN SPECIALTIES, INC.

441 Saw Mill River Road, Yonkers, NY 10701 (914) 476-9000

MODEL No: 0600-T

ISSUED: 1-87

REVISED: 3-99

INTER-LOK TILTING STAINLESS STEEL FRAMED MIRROR

NOTE:
THIS UNIT PROJECTS APPROX. 6" (152mm)
FROM WALL.

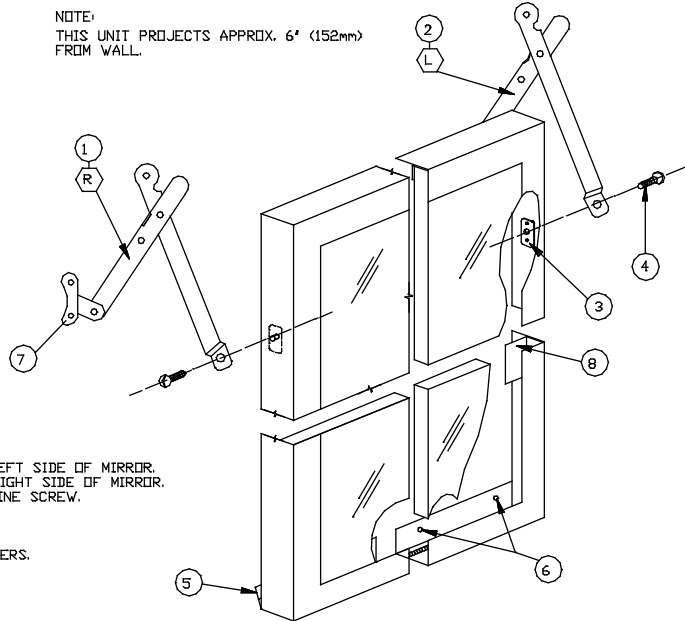

DESCRIPTION-

1. R - STAINLESS STEEL BRACKET MARK R. TO BE USED ON LEFT SIDE OF MIRROR.
2. L - STAINLESS STEEL BRACKET MARK L. TO BE USED ON RIGHT SIDE OF MIRROR.
3. WELDED NUT ON INSIDE OF FRAME TO RECEIVE 8-32 MACHINE SCREW.
4. 8-32 MACHINE SCREWS.
5. CONTINUOUS PIANO HINGE ACROSS WIDTH OF FRAME.
6. MOUNTING HOLES ON HINGE - SECURED TO WALL BY OTHERS.
7. MOUNTING HOLES ON BRACKETS- SECURED TO WALL BY OTHERS.
8. CLIPS FOR HOLDING MIRROR.

SPECIFICATION

Inter-Lok Tilting Stainless Steel Framed Mirror shall have frame fabricated of alloy 18-8 stainless steel, type 304 №18 gauge with mitred corners, welded and ground smooth. All exposed surfaces shall be №4 satin finish. Tilting control brackets shall be fabricated of stainless steel and shall allow mirror to tilt forward for barrier free utility or hold mirror vertical for normal viewing. Mirror shall have a full length stainless steel 3/16" (5mm) dia. multi-staked piano hinge welded to frame at bottom back edge. Mirror glazing shall be ____ (insert glazing option) and shall be warranted for 15 years for silver spoilage. All mirror edges shall be protected with friction and chafe absorbing fillers. Back of mirror shall be protected by full size shock-absorbing water-resistant filler and full size one piece №20 gauge corrosion protected steel.

Inter-Lok Tilting Stainless Steel Framed Mirror shall be Model №0600-T ____ (insert glazing option) as fabricated by American Specialties, Inc., 441 Saw Mill River Road, Yonkers, New York 10701-4913.

MATERIAL

Frame: 18-8, type 304, №18 gauge (.048 in. [1mm] thick) stainless steel. Unitized all welded construction. Exposed surfaces have satin finish. Edges and corners are burr free.

Glass: Standard -A glazing is №1 quality, 1/4 inch (6mm) thick plate/float, silver coated and hermetically sealed with a uniform copper plating, and warranted against spoilage for 15 years. Mirrors meet Federal Spec DD-M411C, ASTM-C1036-91.

Filler: Expanded polyethylene microcell foam sheet material, abrasion resistant and shock absorbing, water resistant, 1/8" inch (3mm) total layer thickness.

Brackets: Stainless steel alloy 18-8, type 304 16 gauge, rounded edges with stainless steel hinge pivot and internal lock.

INSTALLATION

Place brackets right and left of mirror frame using № 8-32 machine screws (supplied). Secure piano hinge to wall with №10 self tapping screws (supplied). Mount pivot brackets to wall. For compliance with ADA Accessibility Guidelines, bottom edge of reflecting surface should be no higher than 40" (1016mm) above finished floor (AFF).

GLAZING OPTIONS

Units are supplied with 1/4" (6mm) thick plate glass mirrors as designated by the -A suffix standard. Other glazing options are available. For a complete description of -A or any other available glazing, see the **MIRROR GLAZING OPTIONS** chart.