



AMERICAN SPECIALTIES, INC.

441 Saw Mill River Road, Yonkers, NY 10701 (914) 476-9000
www.americanspecialties.com

MODEL No: 0600

ISSUED: 1-87

REVISED: 8-05

INTER-LOCK STAINLESS STEEL FRAMED MIRROR

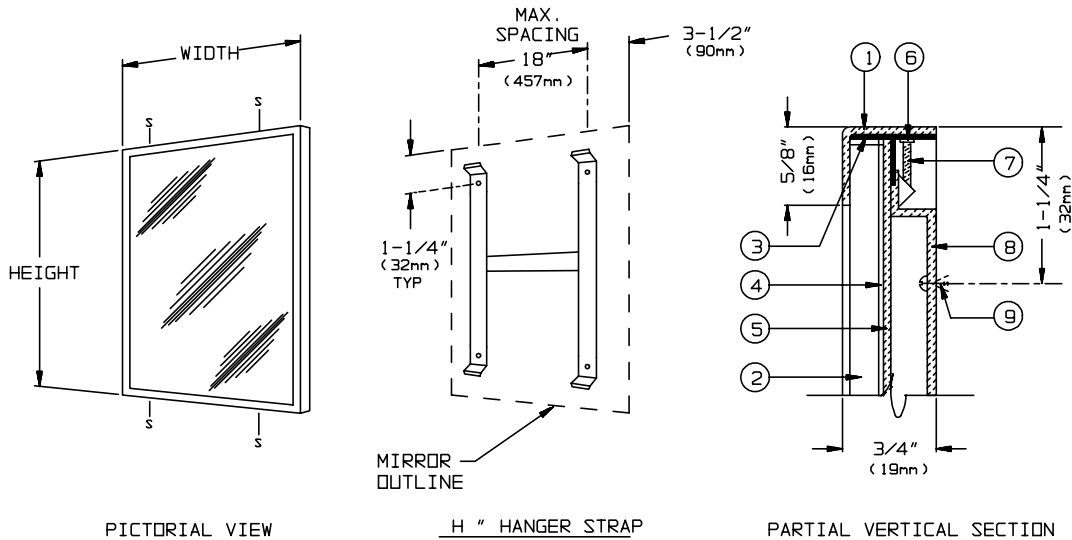

DESCRIPTION

- | | |
|---|--|
| <ul style="list-style-type: none"> 1. 18 GAUGE STAINLESS STEEL FRAME 2. 1/4" (6mm) PLATE GLASS MIRROR 3. SHOCK-ABSORBING EDGE CUSHION 4. NON-ABSORBENT FILLER 5. 20 GAUGE CORROSION PROTECTED STEEL BACK | <ul style="list-style-type: none"> 6. MOUNTING NUT 7. TAMPERPROOF MOUNTING & LOCKING SCREWS 10-32 X 1-1/4" (32mm) 8. HANGER BRACKET- 18 GAUGE 9. INSTALLATION SCREW-FURNISHED BY INSTALLER |
|---|--|

SPECIFICATION

Inter-Lok Stainless Steel Framed Mirror shall have frame fabricated of alloy 18-8 stainless steel, type 304, 18 gauge with mitered corners welded and polished. All exposed surfaces shall be N° 4 satin finish. Mirror glazing shall be ____ (insert glazing option) and shall be warranted for 15 years against silver spoilage. All edges of mirror shall be protected with friction and chafe absorbing fillers. Back of mirror shall be protected by full size shock-absorbing water-resistant filler and full size one piece 20 gauge corrosion protected steel. An 18 gauge corrosion protected steel 'H' bracket shall be supplied. Mirror shall be secured to vertical bracket with corrosion protected allen head locking screws furnished.

Inter-Lok Stainless Steel Framed Mirror shall be Model N° 0600-__ (insert glazing option) __ (note size, W x H) as manufactured by American Specialties, Inc., 441 Saw Mill River Road, Yonkers, New York 10701-4913

MATERIALS

- Frame:** Alloy 18-8, type 304, 18gauge (.048 in. <1.2mm> thick) stainless steel. Unitized all welded construction. Corners mitered, welded and polished. Exposed surfaces shall have N° 4 satin finish. Edges and corners are burr free.
- Glass:** Standard glazing is N° 1 quality, 1/4" inch (6.4mm) thick plate/float, silver coated and hermetically sealed with a uniform coating of electrolytic copper plating, and warranted against silver spoilage for 15 years. Mirrors meet Federal Spec DD-M-411C, ASTM C-1036-91.
- Filler:** Expanded polyethylene microcell foam sheet material, abrasion resistant and shock absorbing, water resistant, 1/8" inch (3.2mm) total layer thickness.

INSTALLATION

Install bracket level and plumb as per diagram location using N° 10 self tapping screws (by others). Hang mirror on bracket and tighten locking screws at top & bottom. For compliance with ADA Accessibility Guidelines, bottom edge of reflecting surface should be no higher than 40" (1016mm) above finished floor.

GLAZING OPTIONS

Units are supplied with 1/4" thick plate glass. Other glazing options are available. For a complete description see the **MIRROR GLAZING OPTIONS** chart.