



**AMERICAN SPECIALTIES, INC.**

441 Saw Mill River Road, Yonkers, NY 10701 (914) 476-9000  
www.americanspecialties.com

MODEL No: 04813-HC

ISSUED: 01-87

REVISED: 02-08

**PARTITION MOUNTED TOILET PAPER DISPENSER WITH SANITARY DISPOSAL**

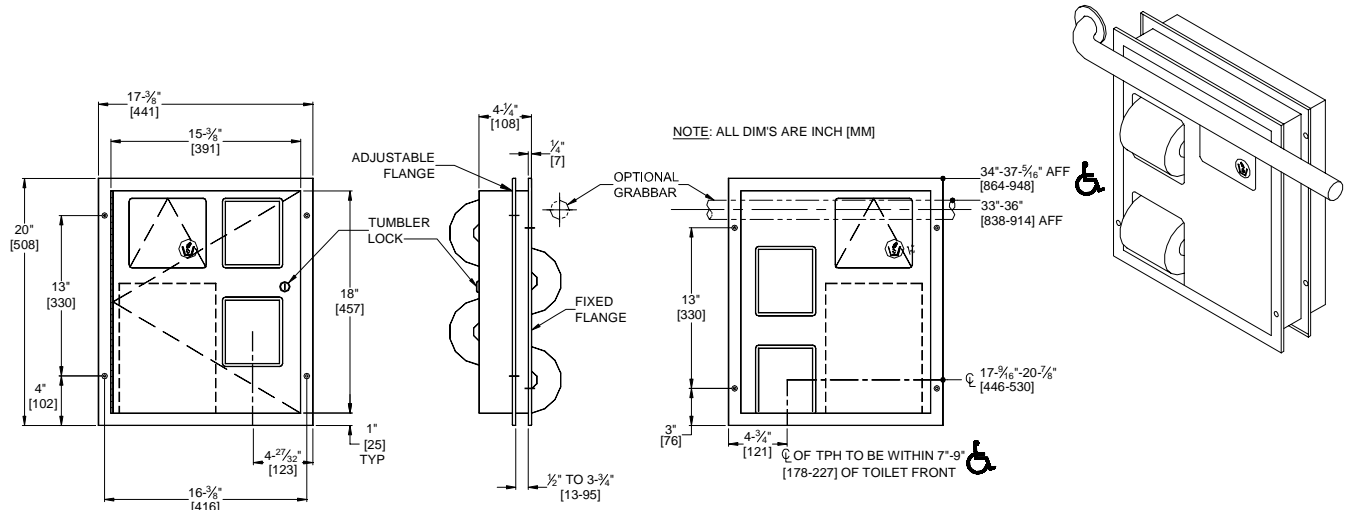

**SPECIFICATION**

Partition Mounted Dual Access Toilet Paper Dispenser and Sanitary Disposal for Barrier Free Access shall hold and dispense four rolls standard or 1800 sheet 4-1/2" x 5-1/4" diameter (114 x Ø133) toilet paper. Removable waste container shall have a waste capacity of 1.3 gal (4.9 liters) or 300 in<sup>3</sup> (.005 m<sup>3</sup>). Waste disposal door and toilet paper dispenser door shall be fabricated of 18 gauge type 304 stainless steel alloy 18-8. Face frame and cabinet shall be 22 gauge. All exposed surfaces shall have N<sup>o</sup> 4 satin finish and be protected by PVC film easily removed after installation. Disposal doors shall be hung on spring-tensioned hinges and shall have international graphic waste disposal symbols. Cabinet door shall be attached to cabinet at side with a full-length 3/16" diameter (Ø5) stainless steel multi-staked piano hinge and shall be held closed with a tumbler lock keyed alike to other ASI washroom equipment. Face trims shall be 1" (25) wide formed from one piece with no miters, welding or open seams and have 1/4" (6) square returns to face of partition. Structural assembly of all components shall be of welded construction. Internal baffles shall prevent line of sight view from either side through unit at any time. Cabinet shall include theft and vandal resistant rollers that shall be of molded high-impact resistant plastic with integral molded-in stainless steel endpins and four (4) rollers [p/n R-004] shall be supplied.

**Partition Mounted Toilet paper Dispenser with Sanitary Disposal for Barrier Free Access shall be Model N<sup>o</sup> 04813-HC as manufactured by American Specialties, Inc., 441 Saw Mill River Road, Yonkers, New York 10701-4913**

**INSTALLATION**

Mount unit in partition using N<sup>o</sup>10 x 3/4" Philips oval head self-tapping screws (supplied). Holes in flanges are offset to prevent screw interference. Install unit so that top of face trim is 34" to 37-5/16" (864 to 948) AFF (Above Finished Floor). Note partition cutout is 7/8" (22) below top of face trim.

**Partition Cut-Out Required: 15-1/2" W x 18-1/4" H x 1/2" to 3-3/4" thick partition (394 x 733 x 13 to 95)**

**OPERATION**

Toilet paper rolls feed freely until depleted and level of supply is constantly visible for low-level warning. Waste receptacle is emptied manually on cycle determined by maintenance needs. Toilet paper rolls and waste receptacle are serviced from one side, for both stalls, by unlocking and opening door. Locked door prevents inadvertent dumping and unauthorized removal. Waste container safety-edged finger hole provides convenient grip for service. Toilet paper spindles are carried in vandal resistant sub-frame accessible when door is opened. Baffle construction preserves privacy between stalls at all times.