



**AMERICAN SPECIALTIES, INC.**  
 441 Saw Mill River Road, NY 10701  
 (914) 476.9000 • (914) 476.0688  
 www.americanspecialties.com

**MODEL №: 0199**

**ISSUED: 10/12**

**REVISED: 03 Oct 2013**

**ADA COMPLIANT SURFACE MOUNTED HIGH-SPEED DRYER ( 1 OF 2 )**

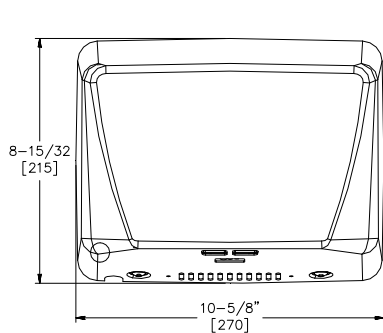

FRONT VIEW

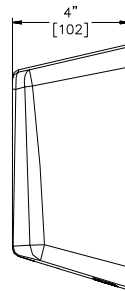

SIDE VIEW

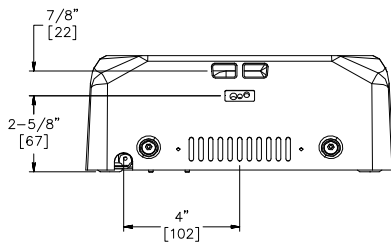
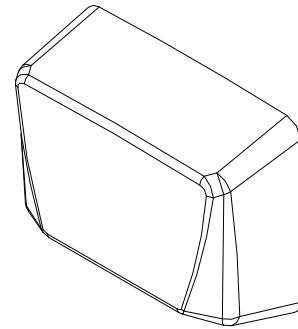

BOTTOM VIEW

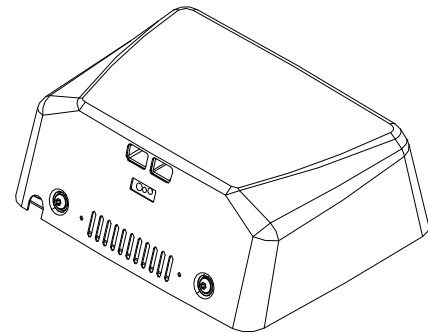

**NOTE:**  
 ALL DIM'S  
 INCH [MM]

**SPECIFICATION**

ADA Compliant Surface Mounted High-Speed Hand Dryer shall operate automatically from IR sensor activated by beam reflection from objects placed in sensing zone. Motor and heating element shall have internal resetting automatic thermal protection. Unit shall develop 60 CFM (102 m<sup>3</sup>/h) of heated air and shall provide drying time of less than 15 seconds. Cover shall be heavy-duty, one piece formed 18 gage stainless steel bright or satin finished on all exposed surfaces (by option specified) or heavy-duty, one piece formed 18 gage steel finished on all exposed surfaces with white porcelain enamel. Fixed directional air nozzle shall be heavy-duty, rust proof and highly tamper resistant. Air intake slots shall not allow access to internal parts. Circuitry shall have self-adjusting time-out and fail-safe off protection controlled by a microprocessor that shall detect and reject false signals and shall automatically self-calibrate to provide uniform sensitivity over its entire life span. Entire unit shall be internally electrically grounded. Dryer unit shall have C-UL-US<sup>®</sup> and CE approval and be listed under the re-examination services of Underwriters Laboratories, Inc. Unit shall be warranted against defects in materials or workmanship for five (5) years. Complete Owner's Manual (OM) and Installation Guide (IG) shall be provided with unit.

**ADA Compliant Surface Mounted High-Speed Hand Dryer shall be Model № 0199 of American Specialties, Inc., 441 Saw Mill River Road, Yonkers, NY 10701-4913**

**INSTALLATION**

Surface mount unit on wall with four (4) 1/4" washers and screws or bolts (supplied) through holes (provided) in a corrosion protected steel back plate into suitable prepared mountings (by others) or other suitable mounting hardware (by others) to suit wall conditions. Electrical service is supplied and connected (by others) prior to installing cover. Cover is secured to back plate with recessed, pin-hex pan head cap screws (supplied) opened with security wrench (supplied). For compliance with ICC/ANSI A-117.1-2003 and 2010 ADA Accessibility Standards for adults install unit with bottom of sensor lens 48" (1219) maximum above finished floor (MAX AFF) if unobstructed reach access is provided or 44" (1118) MAX AFF if forward reach over an obstruction (e.g. vanity or commode) with reach depth greater than 20" (508) and less than 25" (635) is only provided. For general utility install unit so that sensor lens is 44" to 54" (1118 to 1372) AFF. Mounting Template and Installation Guide (MT & IG) is supplied with unit.





**AMERICAN SPECIALTIES, INC.**  
 441 Saw Mill River Road, NY 10701  
 (914) 476.9000 • (914) 476.0688  
 www.americanspecialties.com

**MODEL №:** 0199  
**ISSUED:** 10/12  
**REVISED:** 03 Oct 2013

**ADA COMPLIANT SURFACE MOUNTED HIGH-SPEED DRYER ( 2 OF 2 )**

**OPERATION**

Activate dryer by placing hands under sensor. Dryer automatically shuts off after user removes hands from sensor zone. Complete OM and MT-IG are supplied with unit for future reference of Installation Requirements, Operating Conditions and Service.

**COLOR OPTION\***

Unit is supplied with white finish unless color option is specified. Specify optional cover Bright or Satin Stainless Steel by adding appropriate code number suffix to standard model number (e.g. 0199-1-92 or 0199-1-93).

**RATINGS**

MODEL	TYPE	AIR Velocity	TIMING SAFETY	VOLTS AC FREQUENCY Hertz	AMPS	WATTS x1000	* COLOR
0199-1	Hand	150 ~ 230 ft/S 45.5 ~ 70 m/s	Automatic 60 second Shut-Off	110 – 120 • 50/60	10.4 Max	0.84-1.0	Standard White Optional SS Bright SS Satin
0199-2				208 – 240 • 50/60	5.2 Max	0.75-1.0	
0199-3				277 • 50/60	5.2 Max	1.0	

MOTOR	H/P	RPM x1000	FAN TYPE	HEATING ELEMENT	CFM m <sup>3</sup> /h	AIR OUTPUT TEMPERATURE
Brush Type Dual Ball Bearings	0.67	16-29 (ADJ)	Multi-Inlet Centrifugal	325-450Watt with auto reset circuit breaker Range Adjustable by Owner	42-60 (71-102)	131° F ± 5 @ 77° F (55° C ± 2.8 @ 25° C) Ambient room temp

Net Wt	Ship Wt	DRYING TIME	SENSING RANGE	SAFETY	Water Protection
8.4 Lbs 3.8 kg	9.2 Lbs 4.2 kg	Less Than 15 seconds	Standard = 6" ± 25/32" (152 ± 20)	C-UL-US®, CE	Drip Proof IP23

SENSOR TYPE	DRYING PERSISTENCE	MOTOR THERMAL PROTECTION	HEATER THERMAL PROTECTION	SOUND PRESSURE
IR 780 nm Self-adjusting	Automatic 2 second Hold-On Shut-Off delay	120v Shut off @ > 275 °F { > 135 °C } 240v Shut off @ > 203 °F { > 95 °C }	Shut off @ > 185 °F { > 85 °C } Reset on @ < 167 °F { < 75 °C }	dB-A @ 2M 68.9 Minimum 74.3 Maximum



Accessory Specialties

AMERICAN DISPENSER

Desert Ray Products

WITROUS, INC.