

All Terrain Playground Cart

Components (008)

A	9 pcs	I	8 pcs
B	18 pcs	J	4 pcs
C	2 pcs	Caster	4 pcs
D	16 pcs	2-Way Joint	8 pcs
E	4 pcs	3-Way Joint	8 pcs
F	4 pcs	4-Way Joint	22 pcs
G	2 pcs	End Cap	10 pcs
H	4 pcs		

Assembly Instruction

1. Assemble the cart with a rubber mallet or towel covered hammer. Organize the tubes before assembly.
2. Make the 1st shelf using tubes E, F, and H. Connect by using 4-Way joints.

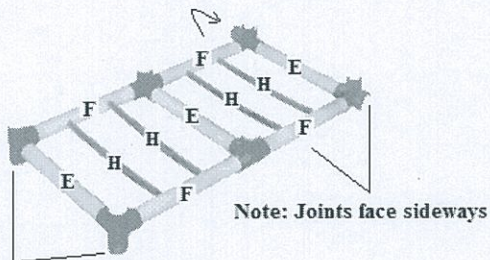

3. Assemble the shelf divider by using tubes G and E. Connect using 2-Way joints. Tap the assembled divider onto the 1st shelf.

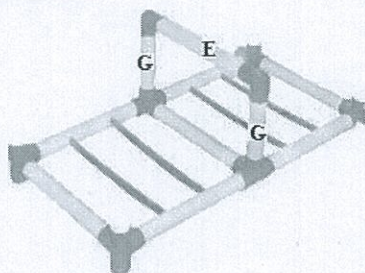

4. Make the 2nd shelf by using tubes A and D. Connect using 4-Way joints and 3-Way joints.

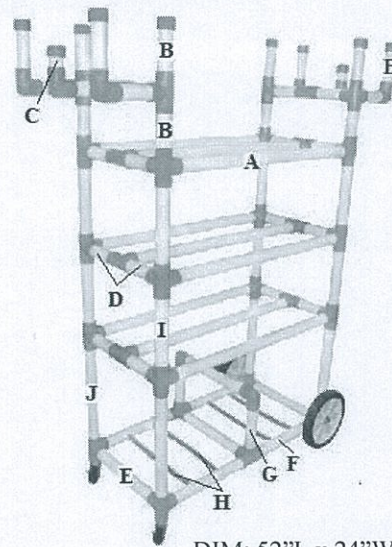
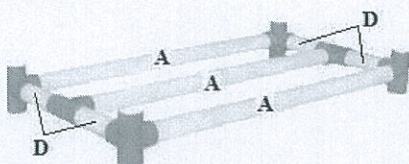

DIM: 52"L x 24"W x 65"H

5. Repeat step 4 for the 3rd and 4th shelf.
6. Insert tubes J into the four corners of the 1st shelf. Tap tubes J in place, attach the 2nd shelf and tap in place.

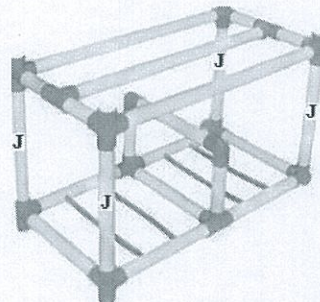

7. Assemble the 3rd and 4th shelf using tubes I as shown below.

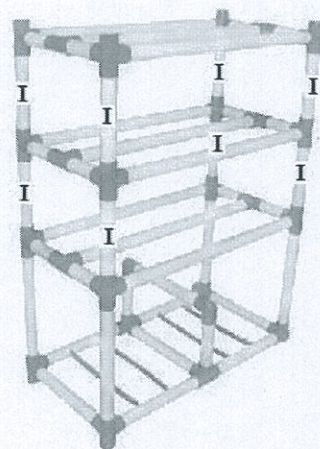

8. Insert tubes B into the four corners of the top shelf and tap in place.

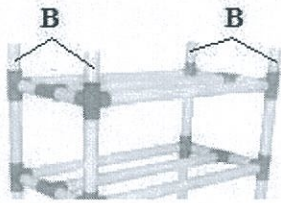

9. Assemble the top assembly using tubes D as shown below. Connect using 4-Way joints and 3-Way joint.

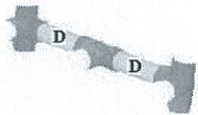

10. Tap two end caps onto two tubes B. Tap tubes B onto the top assembly. Leave it aside.

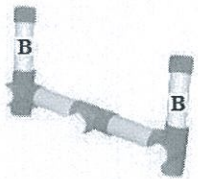

11. Tap end caps onto two tubes B and one tube C. Attach the tubes with a 2-Way joint.

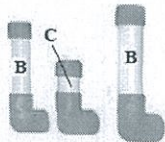

12. Attach the tubes in step 11 to the top assembly (from step 10) using tubes B.

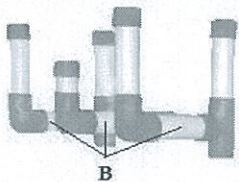

13. Repeat steps 9 to 12 for the opposite side of the top assembly.

14. Attach the completed top assemblies to the cart as shown below.

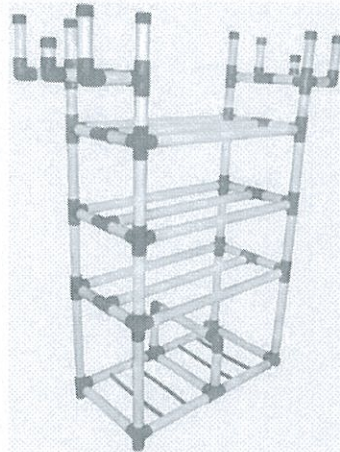

15. Lay the cart on the side, insert two large casters and tap into place on the side, tap two small casters into the bottom.

