

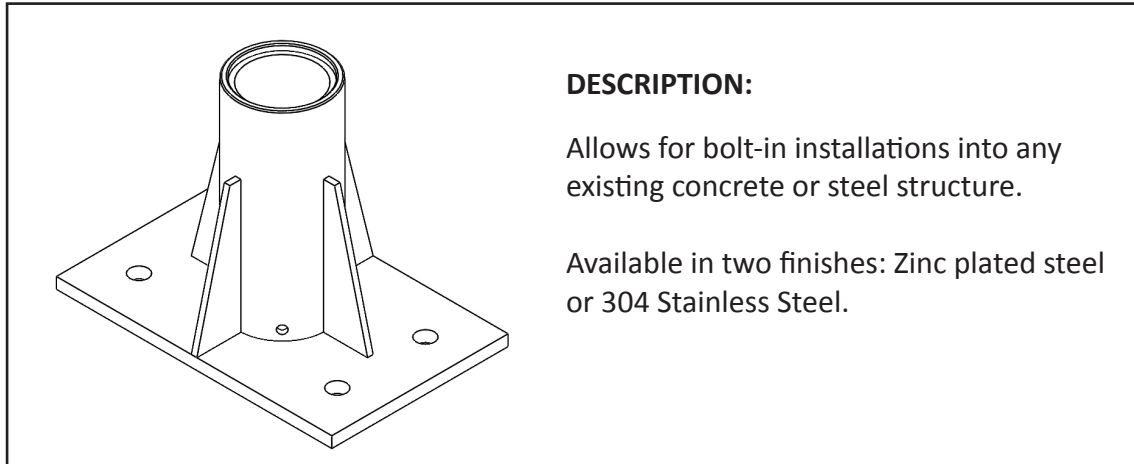

Davit Center Mount Sleeve

65040CMZ (Zinc Plated Steel) / 65040CMS (Stainless Steel)

User Instruction Manual



DESCRIPTION:

Allows for bolt-in installations into any existing concrete or steel structure.

Available in two finishes: Zinc plated steel or 304 Stainless Steel.

GENERAL SPECIFICATION

Rated Capacity (Work load): 620 lbs (281 kg)
@ Minimum 4:1 Design Factor
Mast Moment Proof Load: 74,000 in-lbs (8,861 Nm)
Mast Rotation: 360°
Weight (with sleeve insert): 25 lbs (11.3 kg)

MATERIALS AND CONSTRUCTION

General Construction: Welded Steel/SS
Base-Plate Material: A-36 Steel Plate/304 SS
Sleeve Material: Sch. 40 Pipe/304 SS
Sleeve Insert Material: PVC Pipe, ASTM-D-1785
Finish (Steel): Zinc Plated
Finish (SS): Bead Blasted
Plating Specification (Zinc): ASTM B633-13, Type III, SC2, Yellow

MINIMUM MOUNTING REQUIREMENTS

Concrete Thickness: 9.5 in (241 mm)

The structure and mounting hardware must be capable of withstanding a 74,000 in-lbs (8,361 Nm) moment and a 5,000 lb (2268 kg) vertical load. Installation MUST comply with local regulation standards and be approved by a qualified engineer before use.

To be used in conjunction with the FallTech Davit System only.

PRE-USE INSPECTION

Inspect the Center Mount Sleeve thoroughly for damage, inspection should include checking for dents, cracks, deformed or bent tubing and welded areas for cracks.

Do not use if the Center Mount Sleeve if it fails any part of this inspection.

APPLICATION RESTRICTIONS:

1. Sleeves are to be used with masts and accessories manufactured by FallTech ONLY.
2. System Design factor depends on other system components and the configuration in which they are assembled. The minimum design factor for all standard FallTech safety systems masts and accessories is 4:1.
3. Allow welding to be carried out by qualified personnel.
4. If base material fails to meet minimum requirements, a reinforcement MUST BE added in order to meet minimum requirements.
5. Each installation MUST comply with local regulation standards and be approved by a qualified engineer before use.

This manual is intended to meet the Manufacturer's Instructions as required by the American National Standards Institute (ANSI) Z359 and should be used as part of an employee training program as required by the Occupational Safety and Health Administration (OSHA).

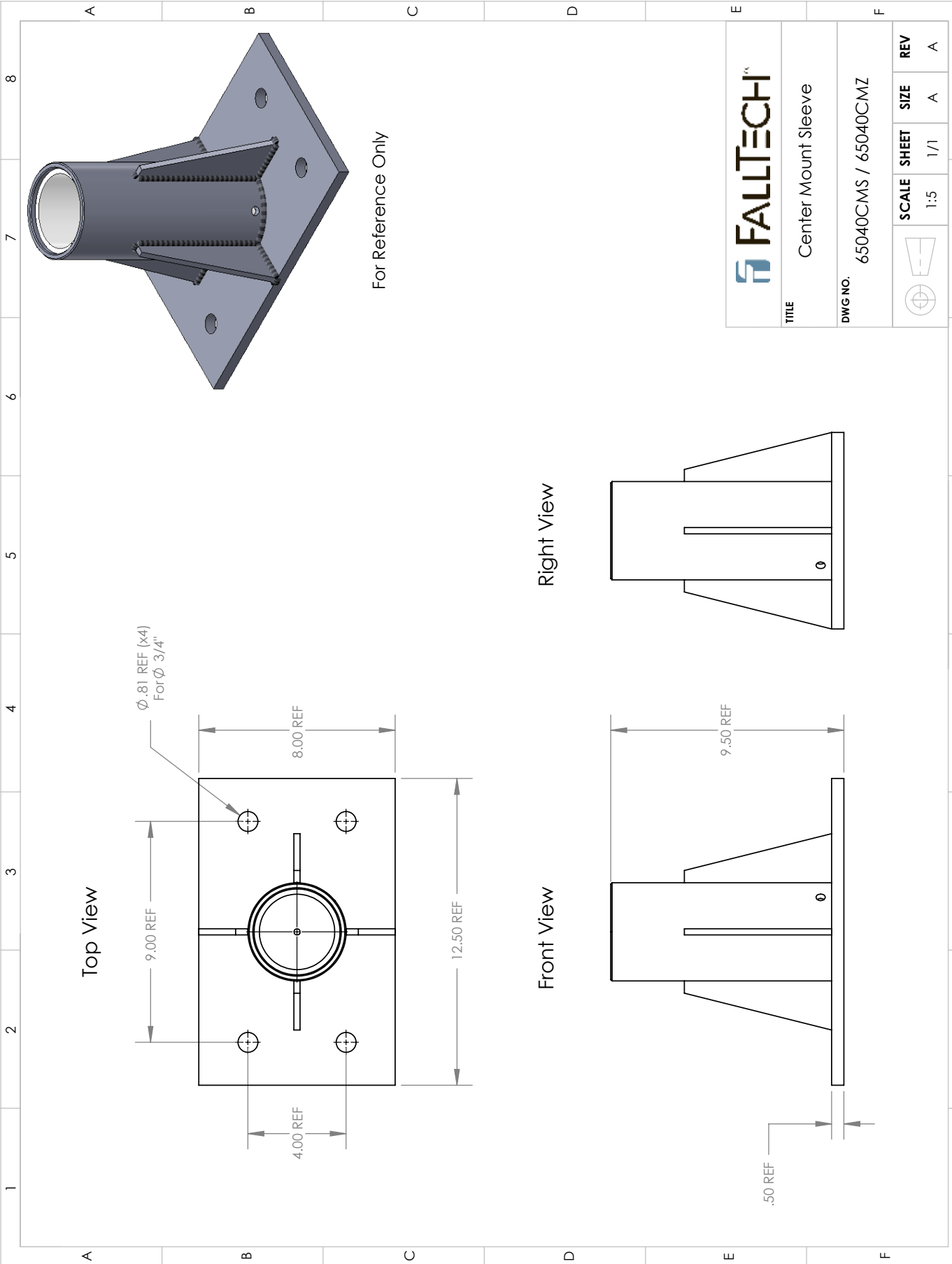

FALTECH™	
TITLE	Center Mount Sleeve
DWG NO.	65040CMS / 65040CMZ
	SCALE SHEET 1:5
	SIZE 1/1
	REV A