

A-912X

Instruction Manual

Please read manual carefully before using and keep it well.

OPERATION MANUAL

A-912X

Autoclave Sterilizer

Please read this manual carefully prior to using your new Autoclave. Following the simple instructions contained in this manual will help to ensure ease of use, trouble-free operation, and a longer working life for your Autoclave. This model is NOT intended for Medical Use.

| | | |
|-----------|----------------------------------|----|
| CHAPTER 1 | LOCATION..... | 1 |
| CHAPTER 2 | SPECIFICATION..... | 4 |
| CHAPTER 3 | PREPARATIONS & INSTALLATION..... | 5 |
| CHAPTER 4 | OPERATION..... | 6 |
| CHAPTER 5 | WARNING..... | 9 |
| CHAPTER 6 | APPENDIX..... | 11 |
| CHAPTER 7 | SIMPLE TROUBLESHOOTING..... | 13 |
| CHAPTER 8 | MAINTENANCE INSTRUCTIONS..... | 14 |

CHAPTER 1 LOCATION

Front View:

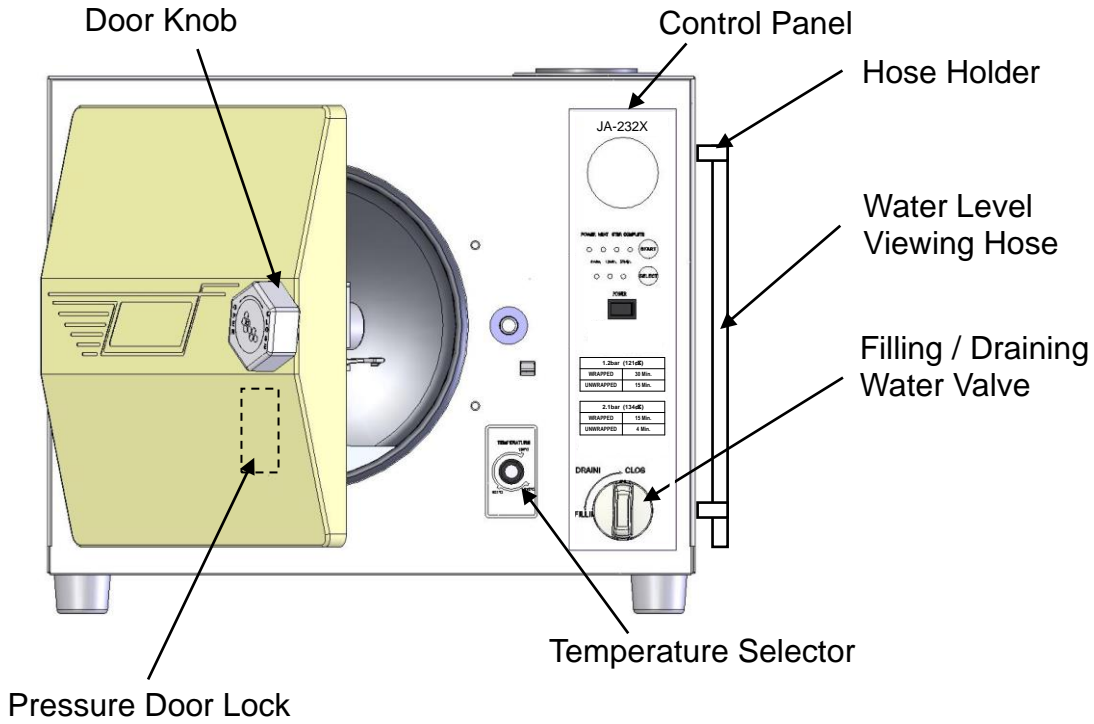

Topside View

Caution: Hot steam will be disposed when draining water from chamber to water reservoir.

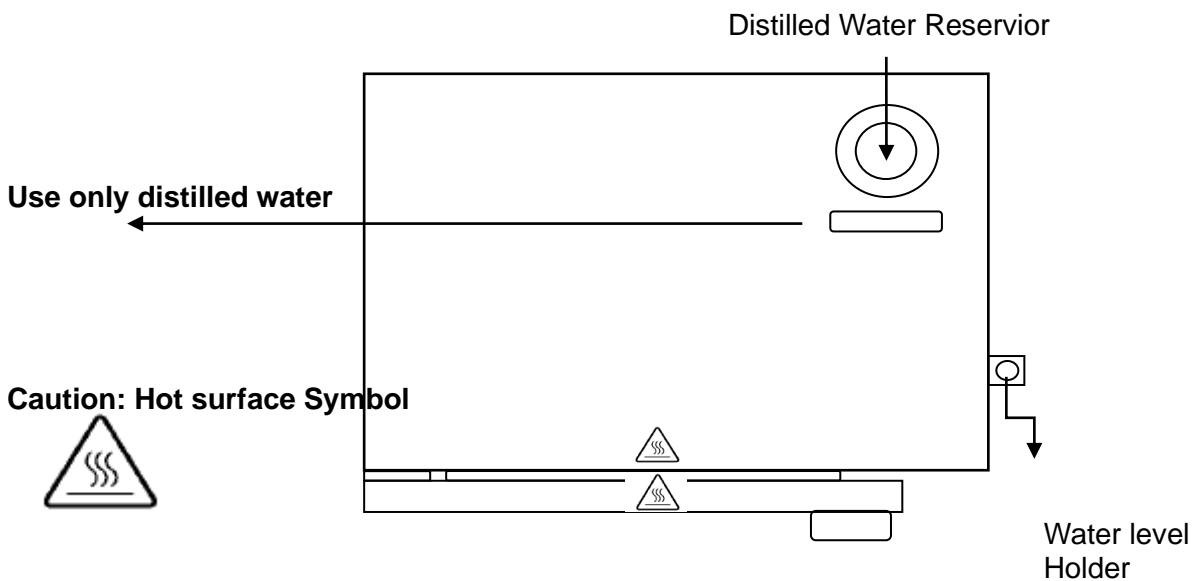

Backside View:

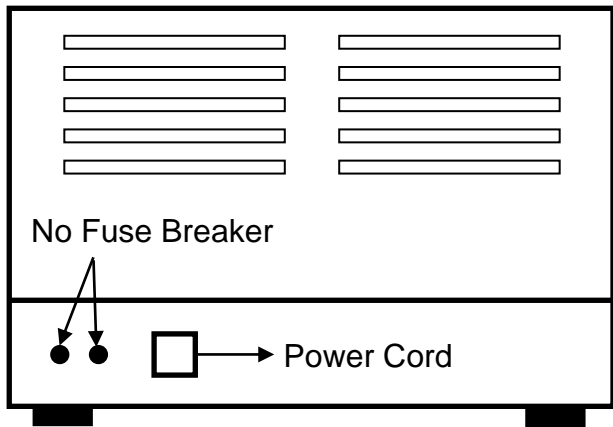

Underside View:

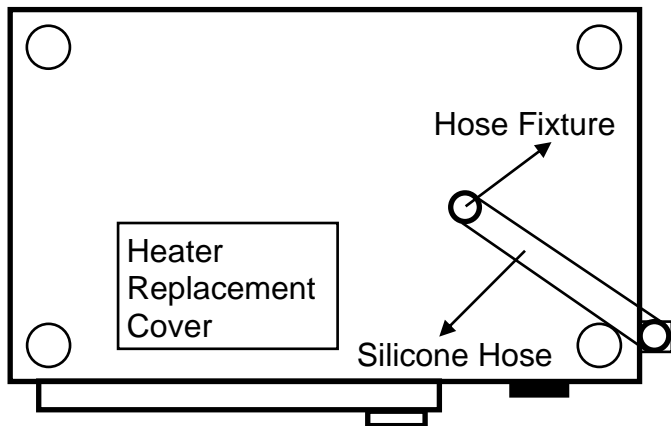

CHAPTER 1 - CONTROL PANEL DESCRIPTION

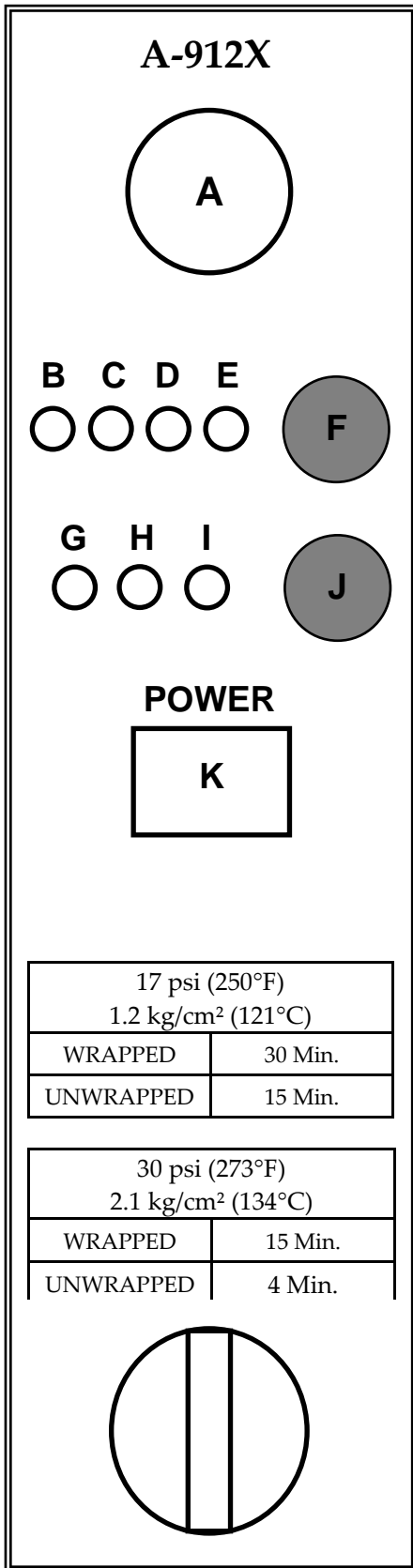

- A. PRESSURE GAUGE
- B. **POWER** INDICATOR
- C. **HEATING** INDICATOR
- D. **STERILIZATION** INDICATOR
- E. **COMPLETE** INDICATOR
- F. **START** BUTTON
- G. **4 Min.** STERI. TIME INDICATOR
- H. **15 Min.** STERI. TIME INDICATOR
- I. **30 Min.** STERI. TIME INDICATOR
- J. **SELECT** BUTTON (STERI. TIME)
- K. **POWER SWITCH** WITH LIGHT

CHAPTER 2 - SPECIFICATION

| | |
|----------------------|--|
| Chamber Size | 230mm \varnothing x 400mm (Depth) Made of stainless steel type 304 (ST. ST. #304) |
| Overall Size | 500mm (W) x 400mm (H) x 540mm (D) |
| Power Consumption | 120V / 1.2 KW (MAX.) / 10A |
| Safety Device | ① Safety Valve ② Low Water (Overheated) Power Cut ③ Temperature Protection Switch ④ Pressure Control Switch |
| Lifetime | 7 years |
| Standard Accessories | Sterilization Box x 1 (ST. ST. #304) |
| Optional Accessories | ① Tray Set (Tray x 3, Frame x 1, Pulling Holder x 1) (Made of ST. ST. #304) ② Spring Holder (Pouch Rack) (Made of ST. ST. #304) |

CHAPTER 3 - PREPARATIONS & INSTALLATION

CHECKLIST FOR UNPACKING INSTRUCTIONS

TO UNPACK AUTOCLAVE FROM CARTON

1. Cut off the bale wire binder.
2. Remove top cover of the carton.
3. Remove wall piece of the carton.
4. Remove foam-packing pieces.
5. Move out the autoclave from the base foam.

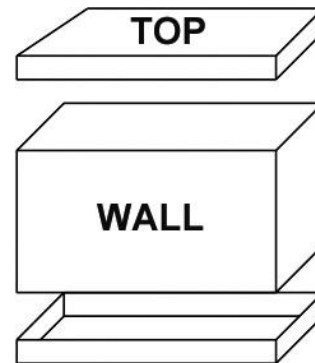

CHECKLIST BEFORE USE THIS AUTOCLAVE

NOTE: Please check the enclosed accessories at first.

1. Put the autoclave on the table, and maintain 5cm min distance between wall and the back of the unit.
2. Keep the autoclave in level condition.
3. Check the Power source is 110V in US.

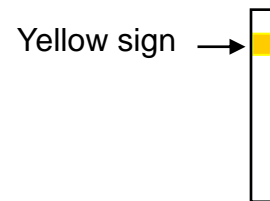

Figure 1

4. Pour water (**DISTILLED WATER ONLY**) into water reservoir until water level is at **FULL** mark sign in the water reservoir. You can also check the water level via water level viewing hose which is located outside the cover. (See Figure 1)

CAUTION: Please **DO NOT** overfill water above the full indicator.

5. Please take power cord out, and plug the male end into a single dedicated grounded AC outlet only.

**POWER SOCKET: 110V / 15A,
230V / 15A (Optional)**

CAUTION: Before plug the power cord, please switch off the power.

6. Press the **Power** switch. If the lamp is lightened, that means the autoclave is electro-powered and is standby mode.

CHAPTER 4 - OPERATIONS

PLEASE CHECK **CHAPTER 3** AT FIRST.

1. Open the door and take out heater cover.
2. Turn the water valve to "**FILLING**" to fill water into chamber. (Water level must cover Heater completely.) Then turn the valve to "**CLOSE**" to stop filling.
3. Put heater cover back to chamber. Then arrange sterilization items (put in the sterilization box or on the tray first) into chamber.
NOTE: Put the steam indicator strip in the meantime if necessary.
4. Select **Sterilization Temperature**. (118°C to 134°C by Temperature Selector)
5. Press the **POWER** switch. (Power switch lamp should be lightened.)
6. Select **Sterilization Time**. (4, 15, or 30 Min. by "**SELECT**" button)
7. Close the door. Then press "**START**" button.
8. Start **Heating** by heater. The "**HEAT**" indicator should be lightened right now. In the meantime, the cold air will be exhausting by steam trap.
9. Pressure rises to the preset value. Steam penetrates through the whole chamber. Start **Sterilization** process for the preset time. (ex.: 4 Min.)
10. Complete **Sterilization**. Buzzer sounds for 40 seconds. If you'd like to take out the sterilization items at this moment, please:
 - A) Turn the water valve to "**DRAINING**", and the chamber pressure will start to decrease. When the Pressure Gauge indicates to "**0**" position, turn the valve to "**CLOSE**". Then you will be able to open door.
 - B) Or you can wait chamber pressure back to atmospheric pressure in order to open the door.



ANY TIME YOU WANT TO OPEN THE DOOR, PLEASE MAKE SURE THE PRESSURE GAUGE INDICATES TO "**0**" POSITION.

CHAPTER 4-1 BASIC STEPS OF STERILIZATION

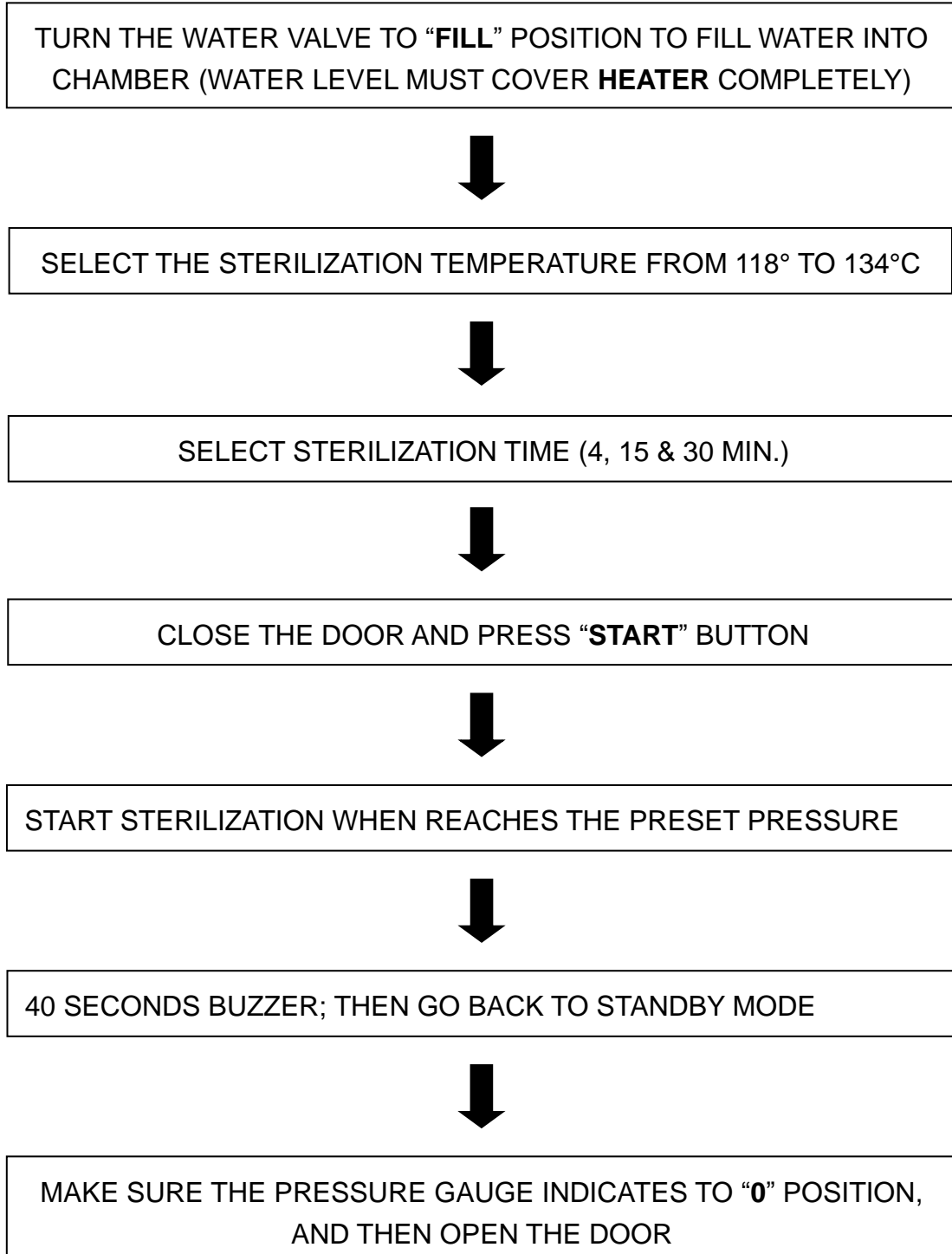

CHAPTER 4-2 STERILIZATION BOX FULLING INSTUCTION

Figure 1



Items to be sterilized

All items need to be placed into the sterilization box. Do not over fill where the box cannot be covered properly.

Figure 2



Place the cover to close the sterilization box.

The sterilization box side vent window to be opened before placing the sterilization box into chamber.

Figure 3

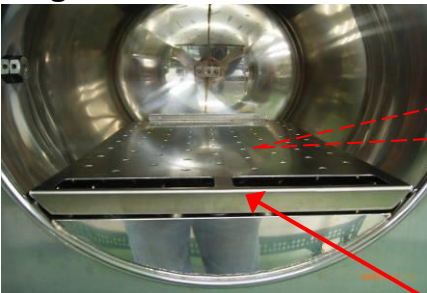

Please check the level of the heater cover when placing into chamber.

Heater cover

Figure 4



Please check heater cover and sterilization box are in horizontal position when the sterilization box is placed into chamber.

CHAPTER 5 - WARNING

PLEASE CHECK THE FOLLOWING ARTICLES CAREFULLY.

1. Anytime before opening the door, please double check the pressure gauge. **DO NOT** opens the door when the pressure inside the chamber is over “0” bar (kg/cm²).
2. Use only DISTILLED WATER or RO (Reverse Osmosis) WATER is necessary for Poleax series. Or we may not be able to offer the quality guarantee.
3. Remember to fill water into the chamber before every cycle.
4. Don't forget to turn the water valve to “CLOSE” after filling water. Or the pressure inside the chamber cannot rise.
5. The door knob must be turned tightly.
Make sure that it touches the blue O-ring can help the door closed completely.
6. Don't overfill water into the water reservoir.
7. The filter inside the chamber and piping system should be cleaned each season at least.
8. We recommend use of chemical indicator strips as a check for sterilization. These strips may also be kept as a record of sterilization.
9. Please pay attention to the high temperature on the top of the housing when it's working.
10. In the event of an emergency, or maintenance, please switch off the **POWER** and unplug the power cord immediately.
11. Signs of CAUTION and INDICATION:

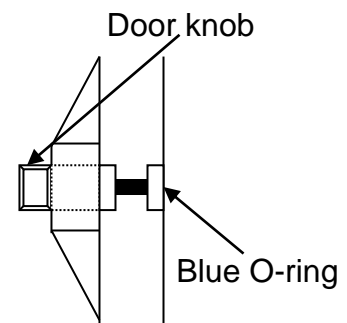

Caution! Hot surface.



Grounding terminal.



This label is meaning that indicator for power off.



This label is meaning that indicator for power on.

12. Storage environment: temperature: $-10^{\circ}\text{C} \sim + 50^{\circ}\text{C}$ / humidity $\leq 80\%$

13. Working environment: temperature: $1^{\circ}\text{C} \sim + 40^{\circ}\text{C}$ / humidity $\leq 80\%$

14. Transportation environment: temperature: $-10^{\circ}\text{C} \sim + 50^{\circ}\text{C}$ / humidity $\leq 80\%$

CHAPTER 6 - APPENDIX

6-1 PROGRAM DETAILS AS FOLLOWS:

**Temperature at 134°C / 273°F Approx. 2.1 bar (kgf/cm²)

| | |
|-----------|--|
| UNWRAPPED | Select 4 Min. sterilization time |
| WRAPPED | Select 15 Min. sterilization time |

**Temperature at 121°C / 250°F Approx. 1.2 bar (kgf/cm²)

| | |
|-----------|--|
| UNWRAPPED | Select 15 Min. sterilization time |
| WRAPPED | Select 30 Min. sterilization time |

FOR REFERENCE: 1 kgf / cm² = 0.98bar = 14.2psi

The sterilization items must be marked as AUTOCLAVEABLE or STEAM STERILIZABLE.



AFTER RUNNING **LIQUID** STERILIZATION PROGRAM, **DO NOT** USE WATER VALVE TO RELEASE THE PRESSURE MANUALLY.
CHAMBER PRESSURE QUICK-RELEASING MAY CAUSE THE GLASS CONTAINER TO CRACK.

6-2 PACKING INSTRUCTIONS:

RE-PACKING INSTRUCTIONS: TO PACK AUTOCLAVE INTO CARTON
(PLEASE REFER TO **CHAPTER 1 LOCATION OF CONTROLS**)

1. Draining off all water from the autoclave, including chamber, water reservoir and hose.
2. Turn off the **POWER** and unplug the power cord.
3. Place all accessories into the chamber. Close the door firmly.
4. Cover the autoclave with the plastic bag.
5. Put the base carton containing the packing bottom-foam onto the floor.
6. Place the autoclave into the base carton and fixed it in the bottom-foam set.
7. Place the wall piece of carton into the base carton.
8. Put 4 pieces of angle paper fixing in each corner of the carton.
9. Put the top carton piece on.
10. Put top foam (4 pcs) on around the top of the autoclave.
11. Close the top of the carton and seal with tape.
12. Use strapping to close the top carton and base carton.
13. The carton is designed with 2 holes on each side for easier handling.

IMPORTANT: We strongly recommend that all packing materials including the carton should to be kept properly. It's for reuse in case the unit needs to be transported again anytime.

CHAPTER 7 - SIMPLE TROUBLESHOOTING

A. POWER INDICATOR ISN'T LIGHTENED

1. **Cause: Power supply isn't connected properly.**
Solution: Re-connect power cord until power indicator light illuminates.
2. **Cause: No Fuse Breaker flicked off.**
Solution: Please contact your distributor for help.
3. **Cause: Over-heating protection is activated.**
Solution: Wait for 10 minutes and the autoclave will restart automatically.

B. AUTOCLAVE ISN'T OPERATING PROPERLY

1. **Cause: Unable to press buttons**
Solution: Please contact your distributor for help.
2. **Cause: Unable to heat up**
Solution: Please contact your distributor for help.
3. **Cause: Unable to enter sterilization step**
Solution: Please contact your distributor for help.
4. **Cause: Unable to complete cycle**
 - 4-1. **Cause: Forget to fill water or water isn't enough.**
Solution: Please refill water and try again.
 - 4-2. **Cause: Water valve isn't closed.**
Solution: Please turn the water valve to "CLOSE" position and try again.

C. COLOR OF STEAM INDICATOR STRIP DOESN'T CHANGE

1. **Cause: Select wrong sterilization time.**
Solution: Please re-select proper sterilization time for the sterilization items and try again.

Any other problems, please contact your distributor for help.

CHAPTER 8 - MAINTENANCE INSTRUCTIONS

DAILY:

- Wipe the inside of the chamber, door and the gasket with a damp, lint-free cloth.
- Check the water level. Top off with distilled water only.
- Drain off the remaining water inside the chamber every time after running a cycle.

WEEKLY:

- Drain off the remaining water left inside the water reservoir and refill with distilled water. (*Please use the water level viewing hose as inference when draining water.)
- Remove the cap of water reservoir and find the safety valve. Pull the ringlet of the safety valve to check its working status.

MONTHLY:

- Clean the chamber and piping system with “**CHAM-MATE**”.
- Use clean water to scrub the water reservoir thoroughly. (It's to clean away the mineral residues of water.)

ANNUALLY: (Please contact your distributor for maintenance.)

- Check the working status of silicone door gasket, steam trap, safety valve, and heater. (Recommendation: Replace the silicone door gasket every year.)
- Test the functions of PCB (Printed Circuit Board).
- Check the temperature during sterilization.
- Use biological indicators to test the validity of sterilization.

WARRANTY

Your Dermalogic Autoclave has a one (1) year guarantee of defective in materials and workmanship under normal use from the date of purchase. Also, this unit is intended use in Beauty / Nail industry. This unit is NOT intended for Medical use and warranty will be nullified.

This warranty does not apply to any product damaged by accident, misuse, abuse, neglect, improper line voltage, drop, fire, flood. Or the products were altered or repaired by anyone other than qualified service personnel.

The liability of seller is limited to repair or replacement and under no circumstances shall seller be liable for any collateral consequential damages or loss. This guarantee specifically excludes the expendables and consumable.

All warranty claims must be directed to the distributors or agents authorized by AYC Group LLC whom are responsible for the sales of this equipment. The customers are responsible for shipping expense.

| |
|--|
| User's Name: _____ |
| Address: _____ |
| Country: _____ Tel: _____ Fax: _____ |
| Date of Purchase: _____ Model No.: _____ |
| Series No.: _____ |
| Distributor: _____ |

Manufacturer: **AYC Group LLC**
1036 S. Jupiter Ste 200
GARLAND, TX 75042 USA
Tel: 972-926-6488 • Fax: 972-926-6477