

Osaki

Ziva

INSTRUCTION MANUAL

*Feel
Better.*

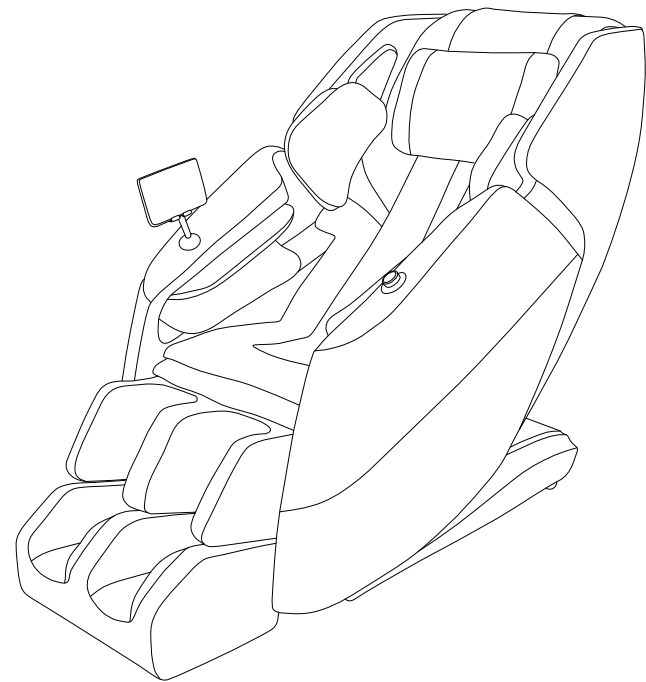

Please read all instructions carefully before using.

- ✦ 1.Thank you for choosing this Massage Chair Ziva.
- 2.Please read this manual carefully before using the massage chair.
- 3.Please keep this manual in a safe place for further reference.
- 4.Please pay attention to SAFETY INSTRUCTIONS.

✦ Note: We reserve the right for design modification.It is subject to change without notice.The pictures in this manual are only for reference. Please refer to the actual product.



Content

Preparation	Safety instructions -----	1
	External structure parts -----	5
	Internal structure parts -----	6
	Mechanical components diagram -----	7
	Mechanical components list -----	8
Installation	Installation -----	9
Massage Operation	The adjustment before massage -----	13
	Manual control -----	15
	Operation instruction &function illustration -----	17
	After massage -----	18
Maintenance	Clean and maintenance -----	19
Others	Malfunction guide -----	20
	Technical data -----	21





Please keep this manual in a safe place for future reference.

- ✦ Please read this manual carefully to make sure the installation and operation of the massage chair is correct.
- ✦ “Safety Instructions” is provided in both Warning and Caution for important safety information.



Both Warning and Caution are important safety caution, please pay more attention.

	Warning	This sign indicates warning of causing possible death or hurt to body.
	Caution	This sign indicates caution of possibly causing pain or damage.



Symbol meaning

	This sign indicates forbidden behavior.		This sign indicates self disassembly is forbidden.
	This sign indicates must follow instruction to operate.		This sign indicates correct operation of cable.

- ✦ The following should be kept for any further references.

 Warning	
 <ul style="list-style-type: none"> ● People with osteoporosis, vertebral fractures, and acute painful diseases such as sprains or muscle strains. ● Heart disease patients (including those who have pacemakers or are using other medical electronics). ● Cancer patients. ● People with perceptual disorders due to high levels of peripheral circulatory disturbances such as diabetes. ● People with abnormal spine or crooked spine. ● People with Protruded intervertebral Disc. ● Pregnant women and those who have just completed childbirth, as well as people with poor health. ● People with trauma, such as thrombosis, acute varices, and various skin inflammations. ● People who have been identified as having lost their ability to discern temperature. ● People with high fever (acute inflammation: such as burnout, chills, blood pressure changes, physical weakness). ● Elderly people over 80. ● Persons with impaired consciousness, mentally handicapped persons, or those who are incapable of operating the unit are prohibited from using this unit. ● People who can not take care of themselves, infants, and intoxicated people. ● Do not use this unit when it is wet or when you are wet. ● It must be taken care of, or not used by people who are not sensitive to heat or people who are allergic to heat. ● Do not fall asleep in this unit. <p>People with above symptoms should not use massage chair, or use it under doctor's advice. User's discretion is advised if use the chair.</p>	<p>Not suitable users.</p> <p>Risk of causing accident or body discomfort.</p>

Warning

	<ul style="list-style-type: none"> ● Before sitting, please confirm that there are no foreign matter inclusions between the various parts of the machine. ● When using the backrest or footrest up and down, make sure that there are no people or objects around (behind, under, or in front of the chair). ● In the event of a physical abnormality or abnormality in use, stop using it immediately and ask a doctor. ● Massage around the head should pay attention to the movement of the massage rollers. The massage rollers should not feel too strong. ● Pay special attention when you massage the area around your neck. ● Avoid excessive neck massage. ● Do not massage the abdomen or knees with this machine. ● If you want to leave your seat during the massage, you must stop the massage chair before you leave the seat. ● Do not use it with other instruments. ● Do not allow children or pets to play on or around the unit (especially in use); nor can they sit or stand on backrests, armrests or legrest. ● When people are unable to communicate, they must have strict and continuous care. ● Before moving the unit, the backrest and legrest must be angled back to their original position. 	Accident/injury
	<ul style="list-style-type: none"> ● When assembling, turn off the switch and unplug it after the chair returns to its default position. ● Insert the plug of the chair into correct and suitable power socket. Make sure the plug is completely inserted into the socket to reduce short circuit or fire risk. ● Unplug the power when not in use, stop all massage functions and turn off on/off key before unplugging. 	Fire and electric shock
	<ul style="list-style-type: none"> ● Massage cushions of the chair are not allowed to be folded for storage. ● The machine is forbidden for no-load running for a long time. ● An appliance should never be left unattended when plugged in. 	Accident
	<ul style="list-style-type: none"> ● Power cord, plug, socket can't be used in broken or loose contact condition. ● Don't use other electric power except rated voltage in case of fire, electric shock or any breakdown. ● Any broken, re-process, knotted, twisted power cord or pressed under heavy cargo is not allowed to use. ● Never operate this appliance if it has a damaged or broken cord or plug. ● Keep the power line away from stove or other heating products. 	Fire and electric shock
	<ul style="list-style-type: none"> ● If the chair is not working or is wet with water in any way, please have it repaired by professional repairman or send the chair to assigned service agent. Self-modification, disassembly or maintenance is forbidden. ● If power cord or plug is damaged, please don't replace it yourself, please contact us or appointed dealer for replacement. ● To avoid electric shock or body injury, please don't open or disassemble any part of the chair, there is not any attached part of the chair for maintenance by customers. ● Check leather or cloth material on the back and other areas for any damage. Regardless of how small the damage is, please stop using the chair and unplug the power to have it repaired. 	Disassembly and maintenance

**Caution**

!	<ul style="list-style-type: none"> This product is intended for use by individuals weighing below 120 kilograms. 	When used by overweight individuals, the product may generate significant noise during operation, and the fabric may wear out more quickly.*	
	<ul style="list-style-type: none"> Please operate the chair in a flat or level place. 	To avoid sudden falling.	
	<ul style="list-style-type: none"> The maximum suggested operating time is 20mins. 5mins for each position beginning with the slight- step massage. Continuous massage in the same position may cause uncomfortable feeling. 	Too long time massage is bad for your body.	
	<ul style="list-style-type: none"> Before sitting on the chair to avoid injury please inspect everything to confirm that the massage heads are in the correct position. 	To avoid accidental injury.	
	<ul style="list-style-type: none"> The tablet controller should be placed on the tablet stand in time, and do not place it randomly to avoid the tablet controller being squeezed or damaged by falling. 		
	<ul style="list-style-type: none"> Please make sure that the power switch is at the "OFF" position before inserting the plug into the socket. 	To avoid the accident when turn on the power.	
	<ul style="list-style-type: none"> Turn off all controls before removing plug from outlet. 	To reduce short circuits and any fire hazard.	
	<ul style="list-style-type: none"> Make sure the plug completely insert into the socket. 	To avoid electric shock in any leakage or breakdown.	
<ul style="list-style-type: none"> Check if there are any damage in the wire and make sure it does not have any water or rubbish on the wire. 			
	<ul style="list-style-type: none"> Installing earth wire in correct way. The plug must be inserted into socket with earth wire, which should not be bent or cut off. 		
⊘	<ul style="list-style-type: none"> Don't press with hands or step on the massage heads with feet. Don't put hands between the working massage heads. Don't put hands or feet in the gap of mechanical parts. Don't drop or embed anything into the slot of massage chair. Don't stand or sit or put anything on the backrest, armrest or leg-rest. Don't move the chair during operation. Don't stand on the chair during operation. Don't pull out the plug or turn off the power during operation. Don't put your hands or head between leg-rest or beneath. Don't use the massage chair while wearing hair ornaments. Don't put hard things in pocket when using buttock and hip massage. Don't sit or press on the backrest when the chair is in reclining position. Don't use at bare skin or wore thin clothes, thin clothes may can achieve better massage effect, but it also may cause irritation to the skin or cryogenic burns. Do not use massager in close proximity to loose clothing or jewelry. Keep long hair away from massager while in use. 	To avoid accidents or injury	
	⊘	<ul style="list-style-type: none"> Keep the chair away from heat, wet, sharp things and corrosive, inflammable, explosive environment. To use electric blanket or other heating products on the chair is forbidden. 	To avoid fade, discolor on upholstery or hardened, deteriorated on PU.
		<ul style="list-style-type: none"> Keep the chair away from stove or other heating products. 	
		<ul style="list-style-type: none"> Don't put the chair directly under the sun or other high temperature places. 	
		<ul style="list-style-type: none"> Don't put in the space of dust serious or corrosive gas environment, 	
		<ul style="list-style-type: none"> Don't put the chair in a small space places or use in the bad air circulation places. 	
	<ul style="list-style-type: none"> Don't use the chair outdoor. 		

**Caution**

⊘	<ul style="list-style-type: none"> Keep Dry-Don't use or store the chair in the wet environment like nearing the swimming pool, or bathroom. Keep the chair and remote control dry all the time. Do not use it when user's body is wet. 	To avoid leakage or electric shock.
⚡	<ul style="list-style-type: none"> Make sure to install the earth wire in correct way(Incorrect install way may cause electric shock. If you don't know how to install, please find a professional electrician) Don't use plug adapter (If the enclosed plug doesn't match with socket, please don't change the plug by yourself and find a professional electrician to install a matched socket.) 	To avoid electric shock.
⚡	<ul style="list-style-type: none"> Unplug the power before cleaning the chair. Unplug the power after using the chair. 	To avoid electric shock or fire hazard.
	<ul style="list-style-type: none"> Unplug the power when any damage on the power. 	
	<ul style="list-style-type: none"> Hold the plug to unplug the power but not try to pull the wire to unplug the power. 	To avoid accidents
	<ul style="list-style-type: none"> Please turn off the power switch and unplug the power after massage. 	To avoid damage or accidents when power on again.
	<ul style="list-style-type: none"> Unplug the power immediately when electricity goes off. 	

Usage environment	Environment temperature: 0°C~35°C Relative humidity: 20%~80%
Storage environment	Environment temperature: -5°C~35°C Relative humidity: 20%~80%

Grounding instruction

- ✦ ※The chair is equipped with a cord having a grounding conductor. The plug must be plugged into an appropriate socket that is properly installed and matches with the plug.

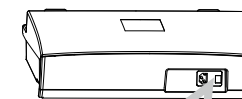
**Replace fuse**

- ✦ ※When the fuse is burned out, please turn off the switch and unplug the power. Opening the lid covered the fuse which is located in the switch box. Using a same size fuse to replace the old one, then cover the lid. Or you can find an electrician to replace the fuse.

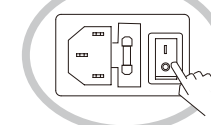
**Earth wire is not allowed to be in these places**

Gas pipe: probably cause explosion or fire.
Phone wire and lightning rod: probably cause electric shock and fire when thundering.
Water pipe: earth wire is useless where there are plastics

External structure

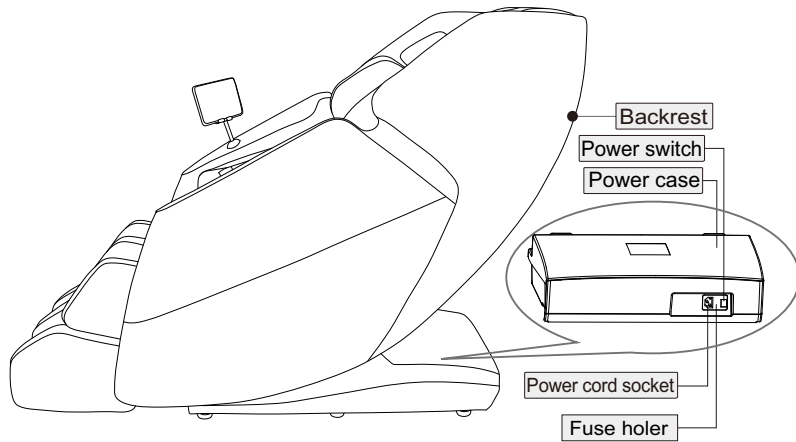
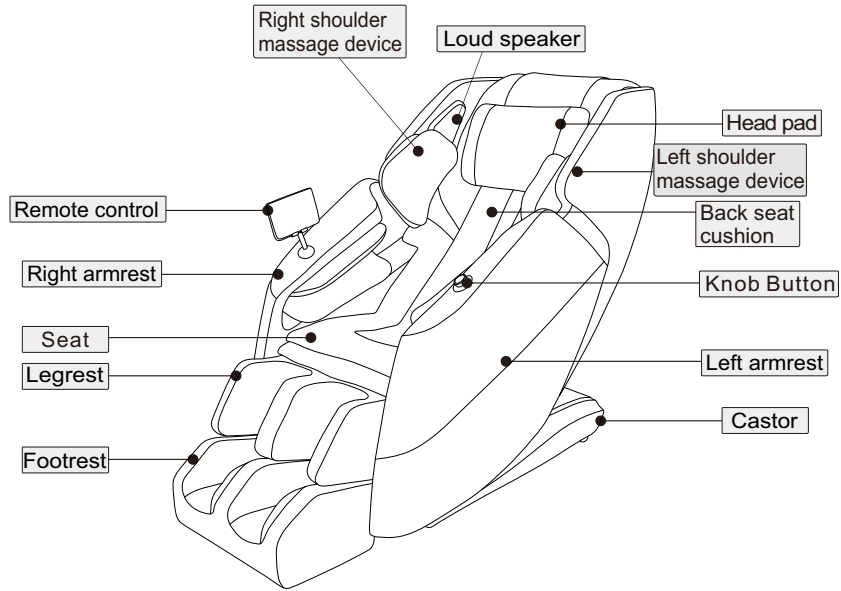

Preparation

Internal structure

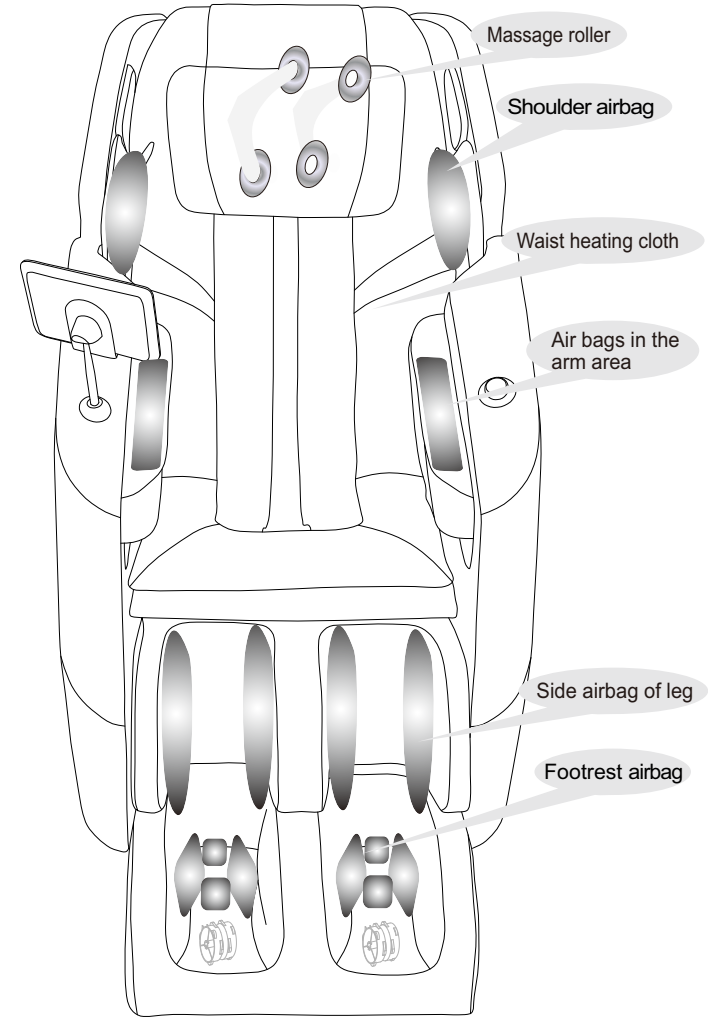

Preparation

Explosion Diagram

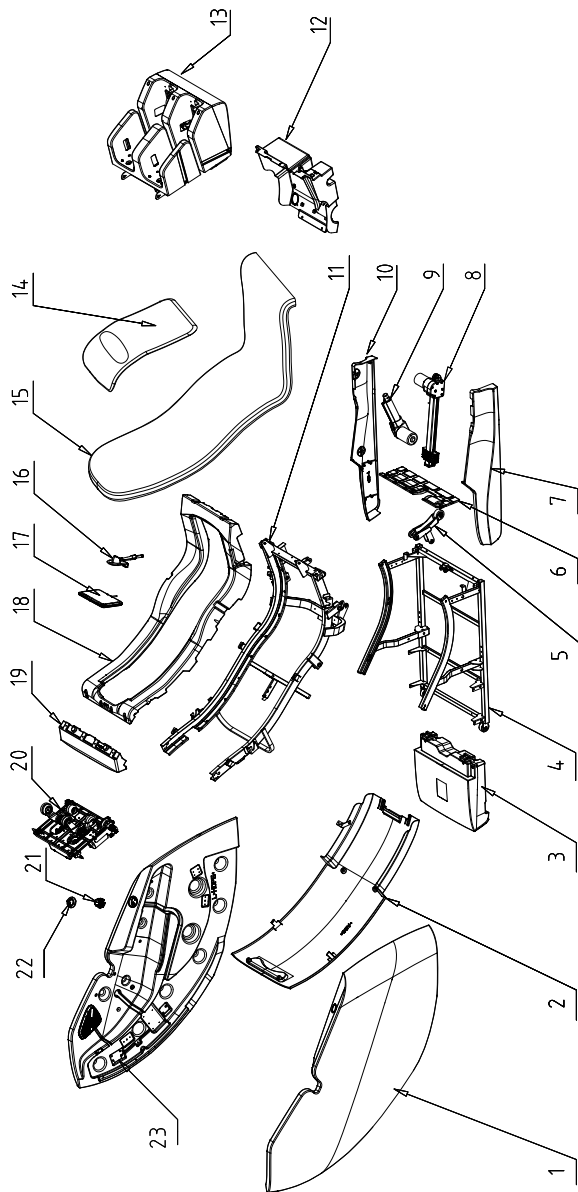

Preparation

Mechanical components list

NO.	Name	Q' ty	NO.	Name	Q' ty
1	Right armrest assembly	1	22	Knob Cover	1
2	Backrest cover	1	23	Left Armrest Assy	1
3	Power box assembly	1			
4	Seat frame welding assembly	1			
5	Leg link (electrophoresis)	1			
6	Front fender	1			
7	Right side fender	1			
8	Pushing actuator	1			
9	Electric actuator	1			
10	Left fender	1			
11	Back frame welding assembly	1			
12	Backrest lower cover	1			
13	Legrest assembly	1			
14	Pillow	1			
15	Back seat cushion	1			
16	Tablet Bracket Assy	1			
17	Tablet Control	1			
18	Lower Backrest Plastic Parts	1			
19	Upper Backrest Plastic Parts	1			
20	Massage Mech	1			
21	Knob Assy Parts	1			

Preparation

Installation (1)

Step 1 Take out massage chair and accessories from the carton box, and reset the footrest.

- ① Take out the accessories box and other parts, and lift out the massage chair body by two or more people.
- ② Turn the footrest from the upper seat to front of the seat.
- ③ Paste the snap fastener of footrest connecting leather on front of the seat.
- ④ Check to make sure that all accessories are complete (please check one by one against the packing list).

Massage chair main body

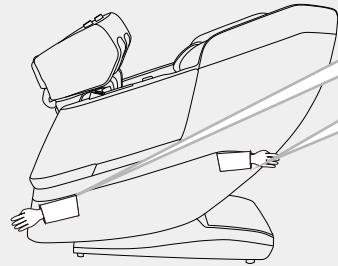

①

Two people each hold the front position of the lower end of the armrest with one hand; Hold the backrest cover handle with the other hand and slowly lift it out.

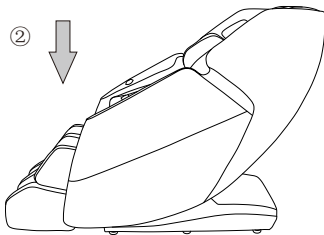

②

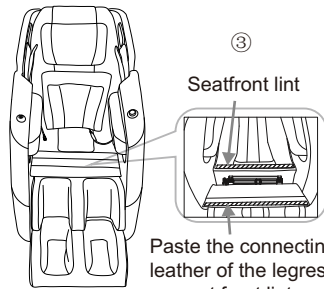

③

Seatfront lint

Paste the connecting leather of the legrest on seat front lint



Tablet control bracket

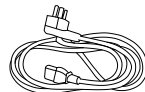

Electric power cable

Installation (2)

● Check environment

- Make sure the recline space.

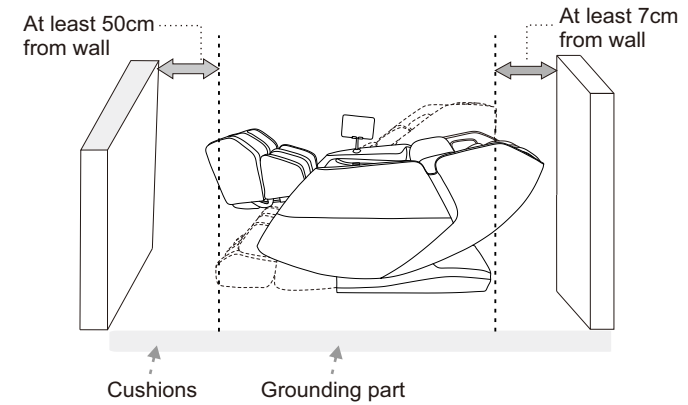

Because the chair is heavy, it may ruin your floor in long time placement. Please put a rug or other soft material to protect your floor.

Installation (3)

Step 2. Assemble controller and controller holder

① Insert the controller holder into the socket on the right armrest, according to the shape of the controller holder and socket hole, until the bottom screw of the bracket snaps into place. ② Put the tablet control on the bracket.

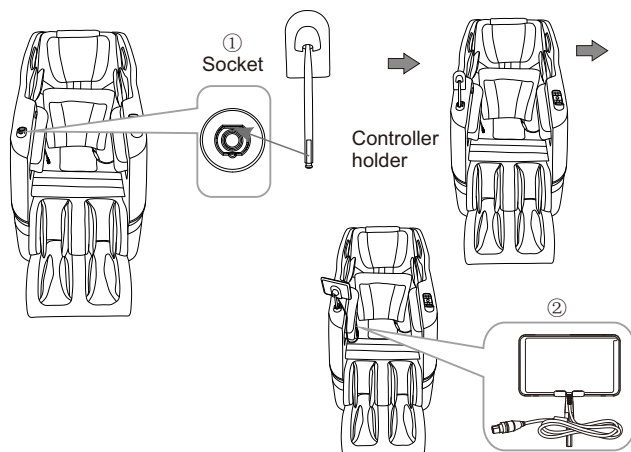
**Step 3. Connect heater wire and back-seat cushion**

Connect the heater wire of waist and seat, connect the back cushion and back with zipper.

★ **Kind suggestion**

Sitting on the chair, try to keep the bottom of pillow and ear in the same line, then connect it with back in this position. It will make body detection more accurate and provide better massage.

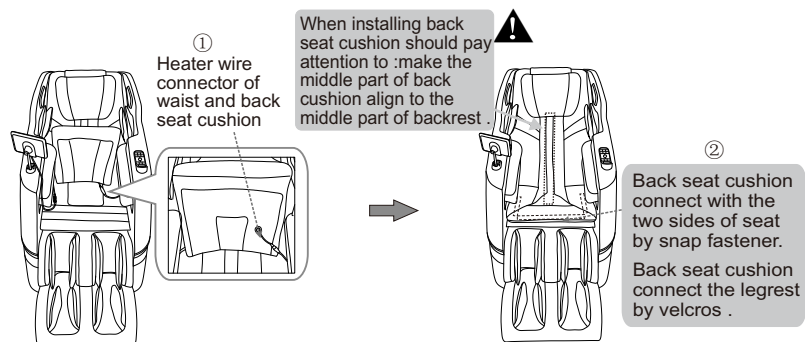

Installation (4)

Step 4. After assembling.

- ① Plug the cable line in the hole a on the power box as shown in the right picture.
- ② Insert the plug of cable line into the socket.
- ③ Turn on the switch behind the power box. (Switch on/off "O/I", press I down to turn it on.)
- ④ Use the hand controller to choose massage functions, enjoy the relax and comfortable massage by our products.

⚠ Make sure the switch is off before you insert the plug of cable line into the socket.

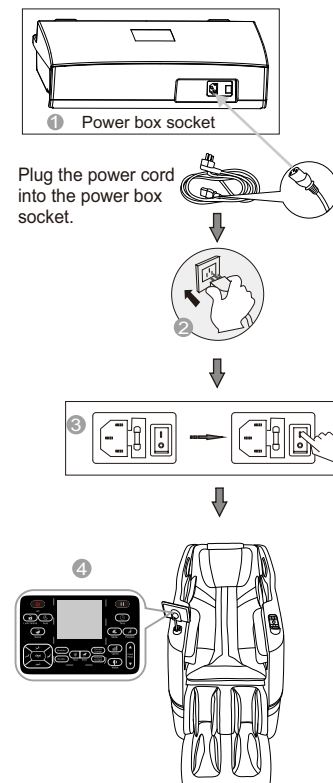

Environment

Caution

Don't use the chair in wet places like near swimming pool, bath room to avoid leakage or electric shock.



Don't use under sunlight or near stove or other heating place to avoid upholstery deteriorated.



Please use chair in flat place to avoid chair falling or noise or other unexpected occurrences.

Check places in front

Check the areas when back and leg extending, make sure no people, pets or other things around.

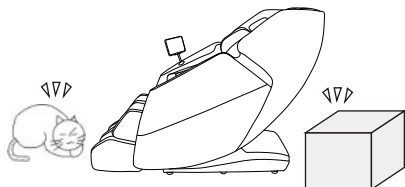
**Check power cable, plug**

- (1) Clean the dust on plug on time. (using dry cloth).
- (2) No damage, re-do, bend, stretch, tie or press with heavy thing (especially can't be pressed by the chair) on power cable.

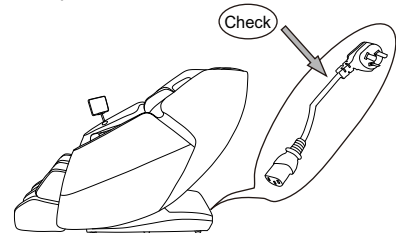

Check environment

Space size for using the chair

- At least 7cm for the back-rest from the wall.

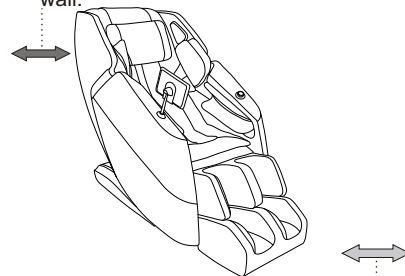

- At least 50cm in front of the leg.

Check surroundings

When the backrest or legrest reclines or extends, please pay attention to:

- (1) Check any person or things in every direction.
- (2) Check the space size.

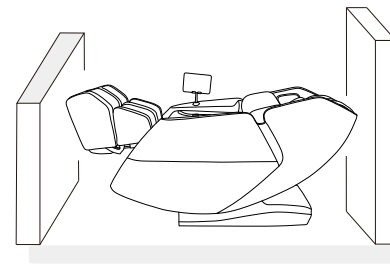
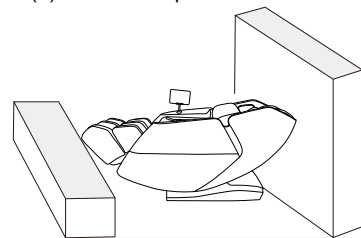

How to move massage chair

Caution

- Don't move chair when it's working in case of accidents or damage

How to move

- Bind the cables and put them in the seat to avoid damage when moving.
- If you plump the chair, it may damage the inner parts of the chair.
- Don't use the castor if the floor is wooden or other easy damaged material. It will need 2 or more persons to lift the chair.
- Make sure the power is off and the plug doesn't touch the floor (It's better to let the chair in standing status to avoid the back crashing the floor)

**Normally**

- Press down the head part to make the gravity fall on the back castors. Then push the chair to desired destination steadily and set it down slowly.

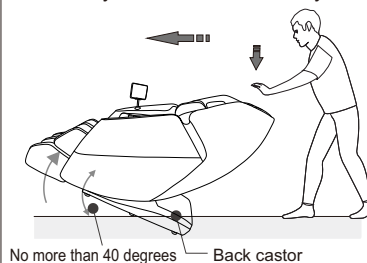

Please hold the footrest to move the chair as shown in the picture in case any scratches on the leatherette

During massage chair backrest lie down process, can't move the armrest.

Adjustment before massage

Before adjustment

- Make sure the massage machine rollers stop in the seat of backrest, then sit on the chair slowly

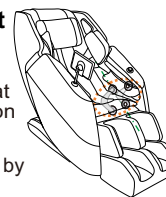

- To avoid injury caused by wrong position of the massage head.

Shoulder height detection

When detecting the height of shoulder, If the massage machine rollers can not find the position of shoulder, it will set the middle back is shoulder by default.

Tip: Press your back into the chair, with your head pressing against the pillow.

**Kind suggestion**

- When you feel the neck massage is not strong enough, please lift the pillow and shoulder cushion, then try the massage again.
- Because the chair is heavy, it may ruin your floor in long time placement. Please put a rug or other soft material to protect your floor.

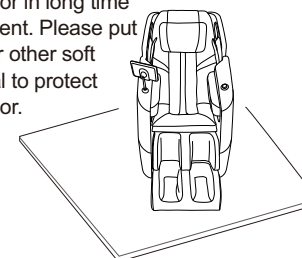
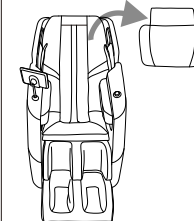

Manual control

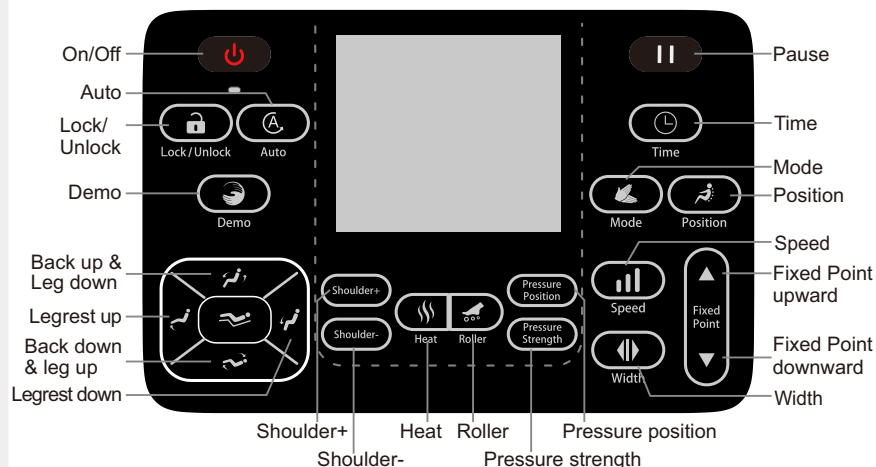

1. In standby mode, press ON/OFF key, the massage chair go into the ON status; In ON status, press the ON/OFF key, the massage chair will turn off and return to original status.



2. In ON status, press this button to pause current function, press it again to continue the function; In pause mode, only ON/OFF button and release Pause button can be used.



Lock/Unlock

3. In ON status, if there is no any operation in 1 minute or press the Lock, all buttons will enter the lock mode, now only ON/OFF, pause and unlock button can be used; Press the unlock button in the Screen to cancel the lock mode.



Auto

4. In ON status, press Auto button, it can circulate in order among the 11 auto programs which shown in the screen. The codes 2 on the screen is Chinese massage, 3 for Pain Relief ,4 for Stretch ,5 for Neck Shoulder ,6 for Glutes, 7 for Relax,8 for Spine Relaxation,9 for Sports Recovery ,10 for Morning, 11 for Middy,12 for Night.



Time

5. In ON status, Press Time button, to adjust the chair massage time, 10mins, 20mins and 30mins for choice.



Demo

6. In ON status,press the button to enter the “Demo” massage program. The code for DEMO is 1 on the screen.



Mode

7. In ON status, press this key to enter manual massage, Pick one manual massage: Kneading, Tapping, Kneading & Tap, Shiatsu, and Knocking..



Position

8. In ON status, manual massage mode ,you can press the button to select whole,partial and point massage.



9. In ON status,press and hold this Pick one manual massage: Kneading, Tapping, Kneading & Tap, Shiatsu, and Knocking.



10. In ON status,press and hold this button to recline the chair. Release the button to stop reclining.



11. In ON status,press and hold this button to raise the legrest up. Release the button to stop raising the legrest .



12. In ON status,press and hold this button to lower the legrest. Release the button to stop lowering the legrest button ,the leg will stop running and lock this position .



13. In ON status,press this button to enter Zero Gravity position Press the button again to set the chair to the initial working state.



Shoulder+

14. In ON status ,after the shoulder height detection is completed, the shoulder height can be adjusted .Press this key to raise the shoulder height ,Release this key to stop shoulder height adjustment.



Shoulder-

15. In ON status ,after the shoulder height detection is completed, the shoulder height can be adjusted .Press this key can lower the shoulder height ,Release this key to stop shoulder height adjustment



Heat

16. In ON status,press this key to turn on and turn off the heating of waist.



Roller

17. In ON status,press this key to turn on and turn off the foot roller.



Pressure Position

18. In ON status,press this key to open the manual air pressing,which can switch between whole body,upper body and lower body and stop.



Pressure Strength

19. In ON status and air pressure massage,press this key to adjust the air pressure intensity .up to 5 levels.



Speed

20. In ON status, and in manual massage mode,press this key to adjust the massage speed ,up to 5 levels except in Shiatsu massage.



Width

21. In ON status, and in manual massage mode, press this key to adjust the massage width: narrow, middle, or wide. This cannot be selected with Kneading and Kneading & Tapping mode.



Fixed Point

22. In ON status, and in manual massage mode,hold the up and down key to adjust the massage machine move up or down,Release the button to stop .

Armrest Knob Button Instruction



In OFF Mode, keep pressing this key for over 1.5s to activate the massage chair, the light in the middle becomes green; press this key shortly to choose among four auto modes repeatedly--Quick Demo, Chinese Massage, Pain Relief and Stretch. The light will change different colors correspondingly. Keep pressing it for over 1.5s to turn off the chair, the light will be off. Rotate the knob clockwise to raise up the seat and legrest, while rotate it counterclockwise to lower down the seat and legrest. Rotate it once, the chair will go up or down to some degree(approximately equal to the up-down movement by pressing the back & leg up down buttons on the remote in 2s.)

ON/OFF

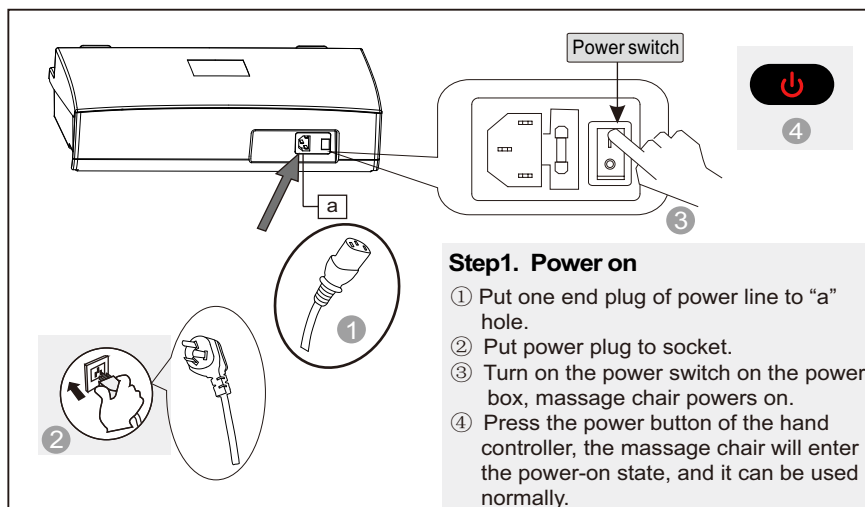

Step1. Power on

- Put one end plug of power line to "a" hole.
- Put power plug to socket.
- Turn on the power switch on the power box, massage chair powers on.
- Press the power button of the hand controller, the massage chair will enter the power-on state, and it can be used normally.

Step2. Massage

- Operate according to controller operation instructions. As for the massage method's details, please refer to remote control's Usage page.
- When the massage ends, massage machine will return to the default position, meanwhile "Shutting down" will be displayed on the controller.



Remote control

Step3. Turn off the power

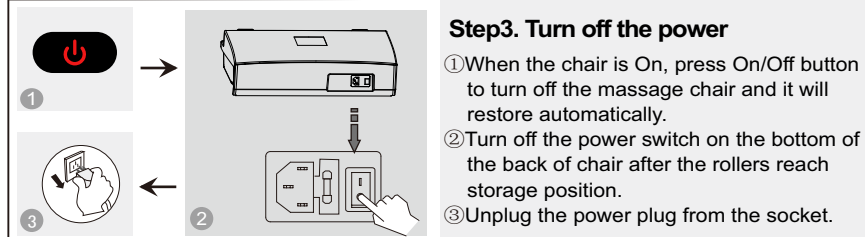

- When the chair is On, press On/Off button to turn off the massage chair and it will restore automatically.
- Turn off the power switch on the bottom of the back of chair after the rollers reach storage position.
- Unplug the power plug from the socket.



Warning

- Before using, pull up the pillow, back cushion etc. to check if the PU material is broken, if there is damage, please stop using, unplug the chair, and ask for repairment.
- Only plug to proper socket.



Attention

- Before sitting down, make sure there is no things pinched between armrest, legrest, backrest and seat of the chair.
- Make sure the chair is in reset state before using.
- Do not stand on it when using the massage chair.
- The upper cover of the power box is provided with a safety anti-pinch device. When there is squeezing or a heavy object between the power box and the back cover of the backrest, the backrest will stop reclining.

Restoration of massage chair

- Make sure there is no people or pet or anything within the range of backrest and legrest.

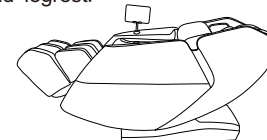

- Make backrest and legrest restore to the normal position by controller.(or press ON/Off key to make backrest and legrest restore to the normal position)

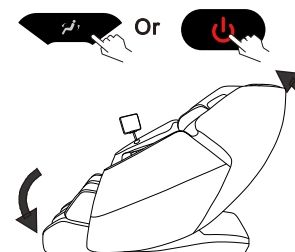

- After the chair restore in place, put the hand controller back on the controller bracket of the right armrest.

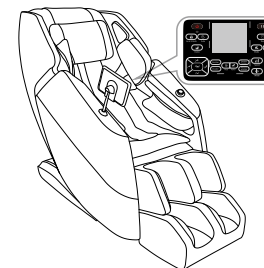

- Switch off the power.

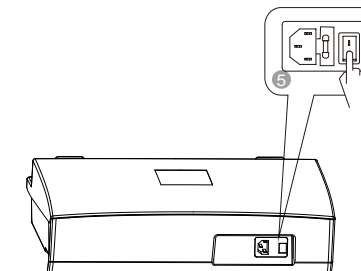

- Unplug the electricity from the socket. (Attention: hold the right plug position)

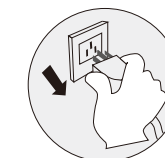

- Clean the chair if necessary.

 Attention!

- After using, press ON/OFF to end all the massage method and wait for restoration. Make sure to cut the electricity to avoid any unexpected hurt to children or pets.
- After using, turn off the power, unplug the electricity. Avoid moisture, dirt and aging of insulation in case of causing damage.



- Please make sure there is no people, no pets or any stuff around the backrest to avoid unexpected hurt or property loss.
- When adjusting the backrest, be careful of the gap between the backrest and armrest.
- When the legrest is moving, please do not stand on or leave from the seat, do not stop the legrest from moving in case of causing damage to the chair.
- Please refer to control instruction for more details.

Synthetic leather

● General cleaning

Clean with tidy, soft and dry cloth slightly.



(Chemical or medical cleaning products are forbidden)



Forbidden

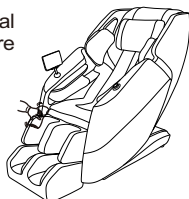

● If leather is dirty

- 1 Dip soft cloth into 3-5% neutral detergent solution, wring it then clean the stain on the surface gently.
- 2 Wash cloth, wring it and wipe with detergent.



- 3 Clean it softly with dry cloth.
- 4 Allow to dry (air blower is prohibited)

Plastic parts

- 1 Dip cloth into neutral detergent, wring it, and then clean.
- 2 Wipe with water-dipped but squeezed cloth.
- 3 Allow to dry.



Clean the controller

- 1 Wipe with soft cloth after squeezing.
- 2 Allow to dry. Propellant, diluent or alcohol are prohibited.



Forbidden

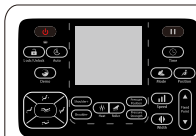

Remote control

Cloth material

- 1 Dip cloth into weak neutral detergent, wring it and clean the material surface.

- (Diluent, gas, alcohol are prohibited)

Brush the dirty parts with weak neutral detergent. (avoid excessive brushing)

- 2 Excessive cleaning may cause damage to cloth material.
- 3 Wipe with water-dipped but wrung cloth.
- 4 Allow to dry.



Forbidden



About cleaning

- Before cleaning, unplug the electricity, don't touch plug with wet hands.
- Make sure hands are dry when plugging to the socket.
- If failed to follow the mentioned instruction, user may get electric shock or burned.

FAQ and Troubleshooting

Trouble	Possible reason	Troubleshooting
The massage chair can't work after power is on.	Check if the control is on or not.	Open control switch
	Not choose massage function	Choose massage function
	Check whether the plug and socket in poor contact.	Make sure plug and socket are connected.
	Wire or plug has damaged.	Please ask manufacturer or appointed or authorized maintenance man for checking and replacement.
	The fuse burned out.	Replace fuse of same specification.
There is beep sound inside the massager while working.	Something wrong with inner circuit	Please ask appointed or authorized maintenance man for checking and repairing.
	It is sound of air pump, motor and mechanical parts.	Normal sound, no need to pay attention to it.
Different height of the left roller and right roller.	Massage rollers work on shifts.	Normal, no need to pay attention to it.
Sound suddenly becomes much louder while working.	Check if it is due to long time working.	Turn off the power to have the massager rest for over half an hour before next turn working.
	Inner parts fretted away due to long time work. It's normal	Please ask appointed or authorized maintenance man for checking and repairing.
Massage function suddenly stops while working.	Suddenly power-down	Connect the electricity power again
	Setting time is up.	Turn off the power to have the massager rest for over half an hour before turning it on again.
Neither the backrest nor the legrest can be lay down.	Check if there are any obstacles; the chair overloads; for the sake of safety, sometimes the massage machine may automatically stop working.	Remove the obstacles; turn off the power to have the massager rest for over half an hour before turning it on again.
	There is heavy things on power box.	
The chair can't return to its original position.	Excessive operation; setting time is up.	Please ask manufacturer or appointed or authorized maintenance man for checking and replacement.
Electric wire or plug give out heat	It may work overload	Turn off the power to have the massager rest for over half an hour before turning it on again.
	Other abnormal case	Stop using, and ask appointed maintenance man for help.



Note: If the troubles are not caused by above reasons, please turn off the power switch and cut off the power, then contact the manufacturer or service agent to repair your chair.

Technical data

Name	Massage Chair	Power	150W
Model	Ziva	NW/GW	80.8/98.8kg
Input voltage	<input type="checkbox"/> 120V ~ 60Hz <input type="checkbox"/> 220V ~ 50/60Hz <input type="checkbox"/> 240V ~ 50Hz	Packing size	1315×790×1185mm (L×W×H)
Safety design	Class I		