

*Osaki*

4D Helix LE Massage Chair

User Manual

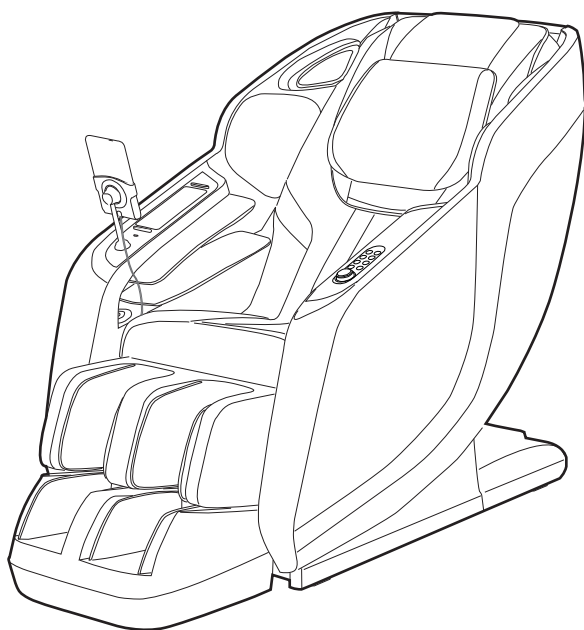

Thank you for purchasing this product. Before use, please read this user manual carefully in its entirety, pay special attention to the safety instructions to ensure proper operation. Retain this manual for future reference.

## Table of Contents

---

### 01 Safety Precautions

### 02 Components & Functions

Exterior Structure .....	3
Interior Structure .....	3
Power Box .....	4
Armrest Controls .....	5
Armrest Control Instructions .....	6
Remote Controller .....	7
Auto Programs .....	8
Manual Programs .....	10
Chair Adjustments .....	11
Settings .....	11
Offline Voice Control .....	12

### 03 Pre-Use Preparation

Installation .....	13
Floor Protection .....	13
Surroundings .....	13
Grounding .....	13
Installation Steps .....	14
Moving the Chair .....	17
Powering On .....	17
Initial Setup .....	18
Before Seating .....	18
After Use .....	18

### 04 Maintenance & Storage





### 05 Troubleshooting

### 06 Technical Specifications

### 07 Other Information

# 01 SAFETY PRECAUTIONS

- ▶ Please read all instructions before using.
- ▶ Precautions and warnings listed below will help to ensure proper operation of this appliance.
- ▶ The classes of accidents caused by incorrect use are classified into WARNING and CAUTION. Read all WARNINGS and CAUTIONS below and follow all instructions within this manual.

 <b>WARNING</b>	Improper operation may cause injury to users.		
 <b>CAUTION</b>	Improper operation may cause injury to users or damage to product.		
	Prohibited		NO Disassemble

## Not suitable for below persons

We recommend that those with any of the following conditions should consult your physician before using.

 <b>WARNING</b>	<ul style="list-style-type: none"> <li>◆ Those with pacemaker or electronic devices implanted in the body.</li> <li>◆ Those undergoing treatment, especially those who are not feeling well.</li> <li>◆ Those with osteoporosis, distorted joints, dysfunction or recent fracture.</li> <li>◆ Those with serious or injured skin conditions; those who are recovering from illness or those who are frail.</li> <li>◆ Those who are pregnant or menstruating.</li> <li>◆ Those with bad fever.</li> <li>◆ Those with malignant tumors, malignant abscesses, hypertension or heart disease. (need to be supervised)</li> <li>◆ This product is equipped with heat function, persons with reduced sensory of heat should pay attention to it. (need to be supervised)</li> <li>◆ Close supervision is necessary when this product is used by, on, or near children, invalids, or disabled persons. (need to be supervised)</li> </ul>
---	---

## Controller Precautions

 <b>CAUTION</b>	<ul style="list-style-type: none"> <li>◆ Do not operate the controller with wet hands or pull the controller wire by force.</li> <li>◆ Do not spill water or other liquid into the controller to avoid fault.</li> <li>◆ Do not lay heavy items on the controller.</li> </ul>
---	---

## Cautions Regarding the Power Connectors and Power Cord





 <b>CAUTION</b>	<ul style="list-style-type: none"> <li>◆ Use matching socket outlet only, improperly grounded appliance may cause risk of electrical shock.</li> <li>◆ Connect the appliance only within the specified voltage to avoid damage to the product or causing fire.</li> <li>◆ Never plug in or pull out power cord with wet hand to avoid shock or injury.</li> <li>◆ Do not drag the cord, reach to the front plastic end to unplug it.</li> <li>◆ Do not put heavy objects on the power cord.</li> <li>◆ Do not damage, over bend, pull hard or twist the power cord.</li> <li>◆ Do not operate the massage chair if the power cord is wet or broken.</li> <li>◆ If the supply cord is damaged, it must be replaced by the manufacturer or its service agent or a similarly qualified person in order to avoid a hazard.</li> </ul>
---	---

# 01 SAFETY PRECAUTIONS

## Best Circumstances

 <b>CAUTION</b>	<ul style="list-style-type: none"> <li>◆ Do not use this appliance where temperature is over 40°C.</li> <li>◆ Do not use this appliance in moist or dusty environment.</li> <li>◆ Unplug from outlet during thunder or lightning storms.</li> <li>◆ Do not use outdoors.</li> <li>◆ Do not store near heat ,open flame or in direct sunlight .</li> <li>◆ Please place the product on the flat level floor.</li> </ul>
---	--

## Best Practices for Safe Use

 <b>CAUTION</b>	<ul style="list-style-type: none"> <li>◆ Only for users weigh below 120kg.</li> <li>◆ Do not use other therapeutic device which is not recommended by us together with this product.</li> <li>◆ Use this product only for its intended use as described in this manual,do not use other therapeutic device together with this product.</li> <li>◆ Appliance should only be used by one person,do not use by two or more persons at the same time.</li> <li>◆ Do not use the product right after meal, it may cause discomfort.</li> <li>◆ Please make sure no ornaments wearing before use to avoid any injuries.</li> <li>◆ Check the upholstery under the cushions and other spots, if any damages are present, do not use it and refer to a qualified service professional for servicing.</li> <li>◆ If you feel any abnormal discomfort during the operation of this product, stop use immediately.</li> <li>◆ It is not recommended to use the unit for more than 30 minutes and not more than 5 minutes for particular part of the body to avoid muscle or nerve pain.</li> <li>◆ Contact your doctor and stop using the product immediately if you experience severe it chiness or rash while in use.</li> <li>◆ Make sure there is no obstacles behind the chair and there is enough clearance before adjusting the backrest or footrest angle.</li> <li>◆ Make sure no other excessive load pressed on the backrest or footrest, keep children, pets or any other barrier away from the unit reclining backrest/extending footrest to prevent any accidental injury.</li> <li>◆ Please be seated properly while using the appliance to avoid injury to the user or damage to the appliance.</li> <li>◆ Don't drag or push the chair or roll on its casters on wood floor or carpet to avoid damage.</li> </ul>
 <b>PROHIBITED</b>	<ul style="list-style-type: none"> <li>◆ Never operate this product if it has damaged / exposed parts or power leakage.</li> <li>◆ Do not stand on or stack heavy objects on the footrest.</li> <li>◆ Children should be supervised to ensure that they do not play with the massage chair.</li> <li>◆ Do not fall into sleep while the product is operating.</li> <li>◆ Avoid using the product under the influence of alcohol.</li> <li>◆ Do not put fingers or foreign objects in the openings of the appliance to avoid injury to the user or damage to the appliance.</li> <li>◆ If there is any smoke or unusual smell while using,stop using immediately, unplug the power cord.</li> </ul>
 <b>NO DISASSEMBLE</b>	<ul style="list-style-type: none"> <li>◆ Do not disassemble this product yourself to avoid product failure.</li> <li>◆ Do not attempt to repair or dismantle the appliance without permission,please contact authorized dealer or service agent for servicing.</li> </ul>
 <b>UNPLUG POWER CORD</b>	<ul style="list-style-type: none"> <li>◆ Never plug in or pull out power cord with wet hand to avoid shock or injury.</li> <li>◆ Pull out the power cord from the power strips before maintenance or after use.</li> <li>◆ Unplug from outlet when the power supply is cut.</li> </ul>

# 02 Components & Functions Reference Guide

## Exterior Structure

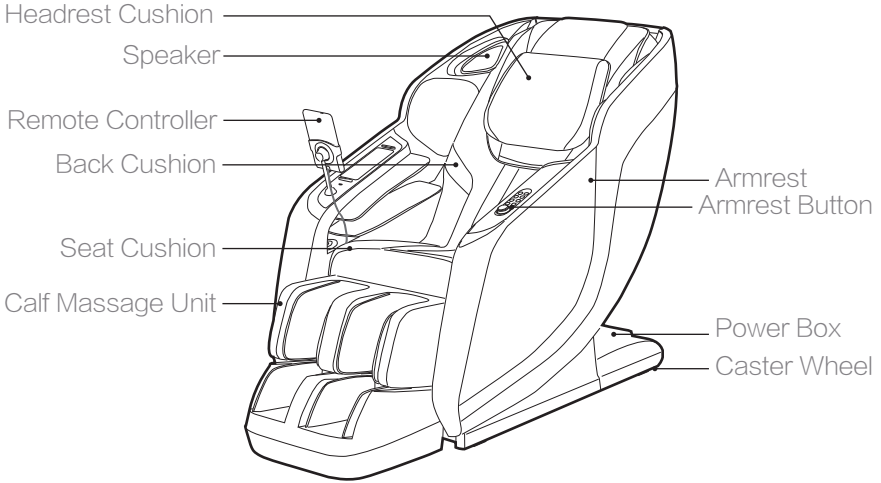

## Internal Structure

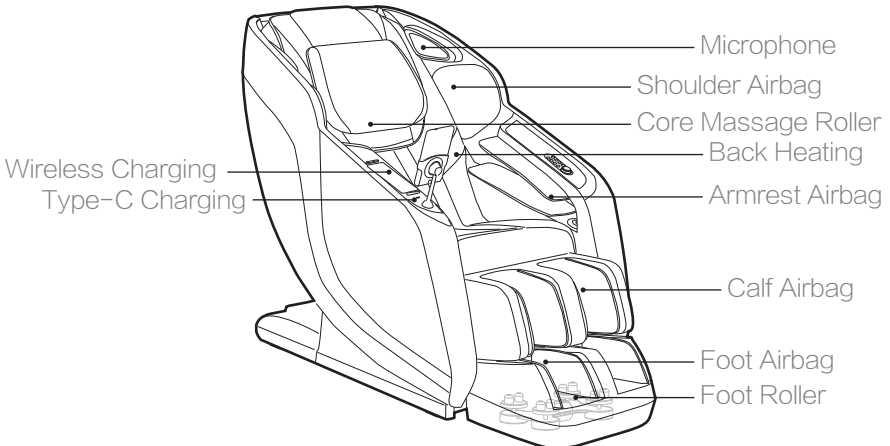

# 02 Components & Functions Reference Guide

## Power Box

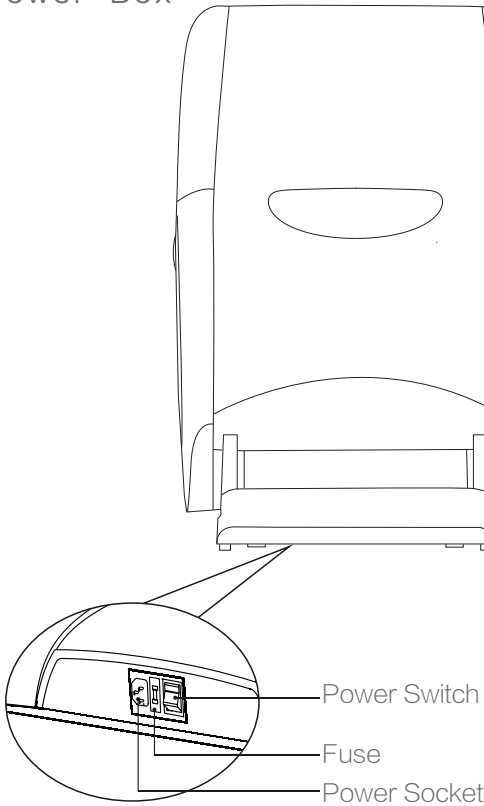

### Caution

- ▶ Do not allow children to play on the massage chair or approach the power supply unit to prevent accidents.
- ▶ After using the massage chair, please turn off the power switch and unplug the power cord from the outlet.
- ▶ Do not use during thunderstorms or rainy conditions.
- ▶ To prevent children from accidentally starting the massage chair and causing accidents, always turn off the power switch and unplug the power cord when the massage chair is not in use.
- ▶ For prolonged non-use, please properly store the massage chair.

# 02 Components & Functions Reference Guide

---

## Armrest Button

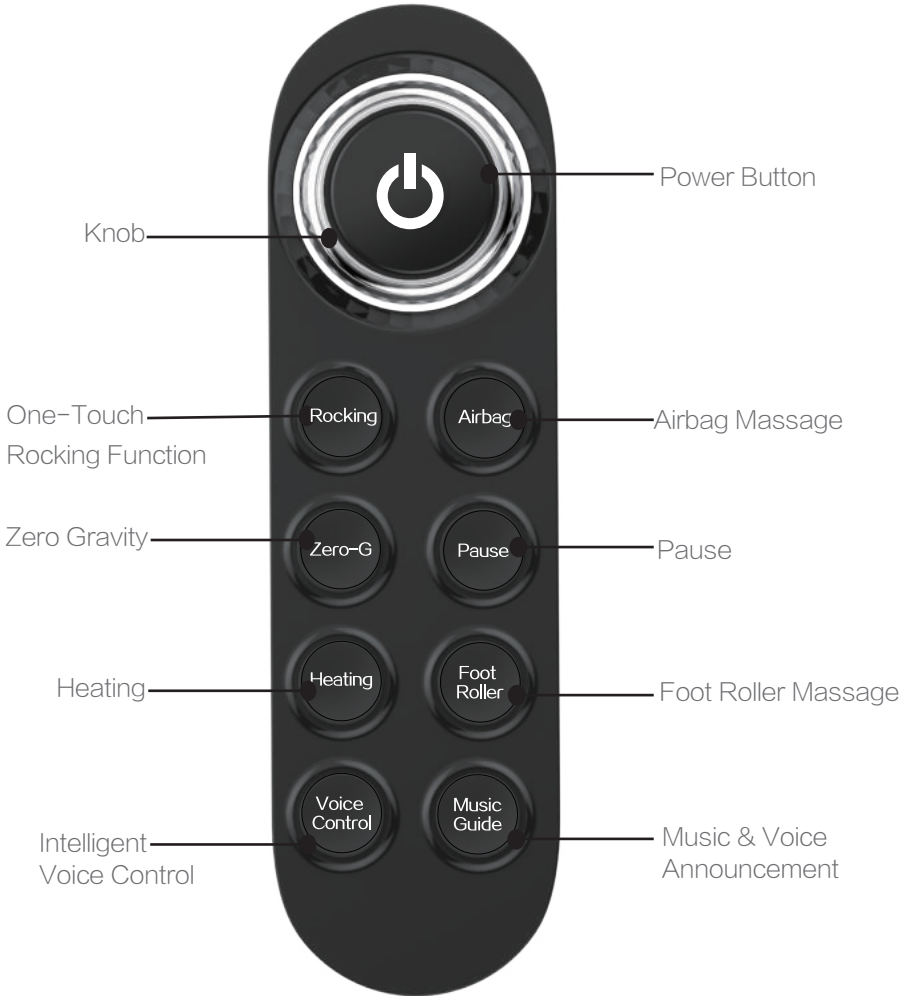

## 02 Components & Functions Reference Guide

---

### Shortcut Remote Functions Guide



#### Power Button

Long-Press: Power On/Power off

Short-Press: Rotate among below auto programs: Recovery Mode, Sports Mode, Gentle Mode, Gamer's Mode, Refresh Mode, Nap Mode (Cycle switch)



#### Knob

Left rotation: Backrest lowers; Right rotation: Backrest raises.



#### Rocking

Short-Press to switched on or off the Rocking Function.



#### Airbag Massage

Short-Press to switch among three different airbag massage programs: Airbag Kneading Massage/Airbag Pulsing Massage/Airbag Alternating Massage(Cycle Switch)



#### Zero Gravity

Short-press to switch among three recline positions: Comfort Zero Gravity/ Deep Zero Gravity/ Zero Gravity Off(Cycle Switch).



#### Pause

Short-Press to Pause or Continue massage.



#### Heating

Short-Press to switch among different heating levels: Heating Level 1 / Heating Level 2 / Heating Level3 / Heating Off (Cycle Switch).



#### Foot Massage

Short-Press to switch among different speed levels of foot roller massage: Level 1 / Level 2 / Level 3 / Off (Cycle Switch).



#### Intelligent Voice Control

Short-Press to switch On or Off the offline voice control function.



#### Music/Voice Announcement

Short-Press to switch among Volume Level 1 / Volume Level 2/ Volume Level 3/ Volume Level 4/ Volume Level 5/ Volume Off.

Long-Press to turn Voice Guide On/Off.

## 02 Components & Functions Reference Guide

---

### Touch Remote Controller

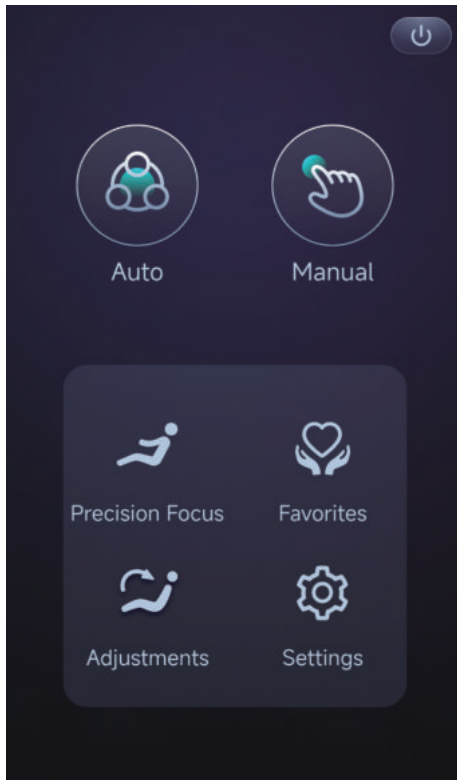

## 02 Components & Functions Reference Guide

---

### Auto Programs

#### **Universal Comfort**

#### **Women's Relief**

A premium program designed for women, featuring personalized slimming massage techniques to enhance body contouring and relaxation, offering a spa-like experience at home.

#### **Men's Relief**

Tailored for men with customized massage techniques and optimal pressure to relieve tension and fatigue, promoting deep relaxation.

#### **Senior Care**

Targets the back, waist, and hips with 4D intelligent massage technology, combining kneading and compression to stimulate acupoints, improve circulation and restore vitality.

#### **Targeted Recovery**

#### **Neck & Shoulder**

Neck & Shoulder Program utilizes advanced 4D massage technology to deliver precise kneading and lifting motions, deeply targeting stiff shoulders and neck areas. This program not only relieves muscle tension but also helps alleviate associated symptoms like headaches and dizziness caused by shoulder strain.

#### **Back & Spine**

Back & Spine Program utilizes 4D massage technology to follow the natural curvature of the spine, applying specialized techniques such as gentle bone loosening, pushing, back stretching, and rolling compression. This program helps nourish internal organs while providing deep relaxation and recovery for the back and spine.

#### **Waist & Hip**

Waist & Hip Program focuses on relieving lower back pain and full-body fatigue, specifically targeting the waist and hips with deep massage techniques. By improving blood circulation, it helps alleviate discomfort caused by prolonged sitting—ideal for office workers and students. It also promotes better sleep quality and overall relaxation.

#### **Deep Relax**

#### **Gamer's Mode**

Provides massage during gaming sessions to relieve tension and muscle stiffness from prolonged focus.

## 02 Components & Functions Reference Guide

---

### **Refresh Mode**

Perfect for social gatherings and coffee chats, offering gentle massage while you enjoy lively conversations.

### **Nap Mode**

Ideal for midday breaks, this program aids digestion and promotes relaxation with gentle massage motions.

### **Air Pressure Massage**

#### **Airbag Kneading**

Maintains comfortable pressure with rhythmic, wave-like compression.

#### **Airbag Pulsing**

Rapidly inflates and deflates to promote blood circulation.

#### **Airbag Alternating**

Inflates and deflates with strong pressure variations for targeted massage.

### **Classic**

#### **Recovery Mode**

This program employs a gradual intensity progression (light to firm) to deliver full-body relaxation, effectively alleviating muscle soreness and accelerating fatigue recovery. Featuring exclusive massage techniques, it specifically targets: neck/shoulder stiffness from prolonged sitting, lower back tension, whole-body stress relief.

#### **Sports Mode**

This program delivers moderate-pressure full-body massage specifically designed for post-workout recovery. It progressively relaxes muscle groups throughout the body, effectively alleviating exercise-induced soreness in the neck, shoulders, back, waist, and legs while improving flexibility and accelerating muscle recovery.

#### **Gentle Mode**

This program uses gentle kneading motions combined with rhythmic rocking movements to effectively relax both body and mind. By promoting blood circulation, it helps alleviate general discomfort.

## Massage Adjustment

### **Intensity Level:**

Switch the 4D intensity among three levels: Gentle/Soothing/Powerful.

## 02 Components & Functions Reference Guide

---

### **Airbag Adjustment:**

Switch airbag pressure area among three locations: Shoulder, Arm, Leg&Foot.

### **Heating Adjustment:**

Switch heating level among 1,2,3 and Heating Off.

### **Foot Rollers Adjustment:**

Switch foot rollers speed among 1,2,3 and Rollers Off.

## **Manual Programs**

### **Technique:**

Kneading, Sync, Tapping, Rubbing, Knocking, Shiatsu

### **Point Massage:**

Control the mechanism to walk up and down in Point Massage Mode.

### **Massage Area:**

Whole (whole body), Partial (part of body) and Point (targeted area).

### **Massage Width:**

Narrow, Medium, Wide. This controls the location of the rollers and their distance from your spine.

Note – width is not adjustable if Kneading or Sync or Rubbing is selected.

### **Massage Speed:**

Massage speed can be adjusted up to 6 levels.

Note Speed is not adjustable if Shiatsu is selected.

### **4D Intensity:**

The rollers can extend from the track up to 5 levels for a stronger massage. This feature can be turned off.

### **Air Pressure Are:**

Choose from Shoulder, Arm or Leg&Foot.

### **Air Pressure Intensity**

Adjust the pressure of the air cushions up to 5 levels or turn off.

### **Back Heating:**

The back heating can be set up to 3 levels or turned off.

### **Foot Roller:**

Adjust the speed of the foot rollers up to 3 levels or turn off.

# 02 Components & Functions Reference Guide

---

## Precision Focus

### Head Relief

Alleviates mental fatigue caused by cognitive work.

### Neck Massage

Relieves neck stiffness and fatigue caused by prolonged sitting.

### Shoulder Massage

Alleviates shoulder fatigue and muscle soreness.

### Back Massage

Eases back fatigue and muscle soreness.

### Waist Massage

Improves lower back soreness and muscle strain.

### Hip Massage

Shapes and tones for optimal body contouring.

### Leg Massage

Relaxes leg muscles and enhances muscular function

## Favorites

Adjusted operation modes can be saved as favorite programs (maximum 3 favorites). (Manual programs cannot be saved as favorites).

## Adjustments

### Rocking Mode:

Switch between Rocking Mode On and Off. Massage Chair will Rock automatically if it's switched on.

### Zero Gravity:

Adjust the chair to recline to Relax Zero Gravity or Deep Zero Gravity or Zero Gravity Off.

### Massage Time:

Set the time of your massage to 10mins, 20mins or 30mins.

### Back Up/Down

Tap and hold the icon to recline or raise the massage chair.

### Leg Up/Down

Tap and hold the icon to lift/lower the massage chair footrest.

### Extend/Retract

Tap and hold the icon to extend/retract the footrest.

## Settings

### Bluetooth:

On/Off (Note: "Turning off Bluetooth will stop phone music playback".)

Volume: Volume levels adjustment

# 02 Components & Functions Reference Guide

### Sleep Mode:

On/Off (When enabled, chair won't reset after program completes.)

### Screen Brightness:

Screen brightness adjustment | Screen Timeout: 10/20/30min

### Language:

Simplified Chinese(中文) / English(英文)

### Child Lock

Child Lock switched between On/Off

### Support

Information of supplier

### Software Version

Software information of this massage chair

### Voice Control:

Voice Control Switch: On/Off

Command List

## Offline Voice Control

For optimal offline voice control performance, please turn on the chair and turn off the massage chair's ambient music and disconnect any Bluetooth audio devices in advance

to prevent interference with voice recognition.

Detailed command list can be found in Settings-Voice Control.

Voice Command
Hi Osaki / Hey Osaki
Power off
Zero gravity
Pause
Continue
Turn on heat
Turn off heat
Women's Relief
Men's Relief
Senior Care
Neck & Shoulder
Back & Spine
Waist & Hip
Head Relief
Neck Massage
Shoulder Massage
Back Massage
Waist Massage
Hip Massage
Leg Massage
Gamer's Mode
Refresh Mode
Nap Mode
Recovery Mode
Sports Mode
Gentle Mode
Airbag Kneading
Airbag Plusing
Airbag Alternating

# 02 Components & Functions Reference Guide

## Position & Placement for Installation

Clearance space for the massage chair:

- ▶ Please allocate a minimum 7.87 inches distance clearance for the back of the product;
- ▶ Please allocate a minimum 8.66 inches distance clearance for the footrest of the product.

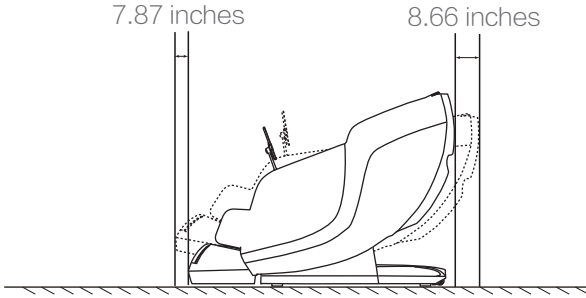

### Floor Protection

- ▶ We recommend to place a piece of carpet or soft mat underneath it to avoid damaging the floor.

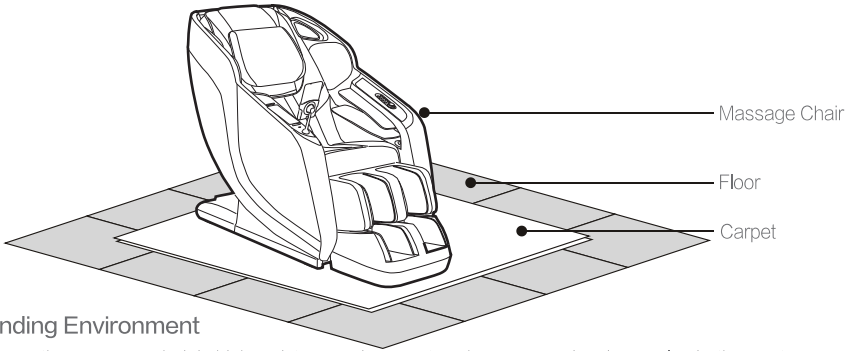

### Surrounding Environment

- ▶ Do not use the massage chair in high moisture environment such as near swimming pool or bathroom to prevent electric shock accident.
- ▶ Please keep the massage chair away from heated surfaces to prevent fire hazard or damage to the product.



### Grounding

- ▶ This product must be grounded, the plug must be plugged into an appropriate 3-wire grounded outlet that is properly installed and grounded in accordance with all local codes and ordinances to reduce risk of electrical shock.

# 03 Pre-Use Preparation

## Installation Instructions

### Step 1: Unpack All Components

- ▶ Open the packaging carton and carefully remove the upholstery set, accessory box, and other components.
- ▶ Verify all accessories against the packing list to ensure completeness.

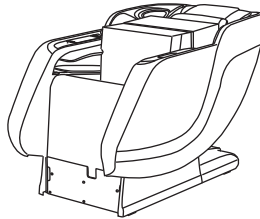

### Step 2: Calf Massager Installation

- ▶ Lift the calf massage module from the packaging and align it properly with the chair frame.
- ▶ Connect the chair to power, reset it to the fully upright position, then disconnect power before proceeding.
- ▶ Connect the drive cable plug and air tube from the calf assembly to their corresponding ports under the seat frame, ensuring secure engagement.

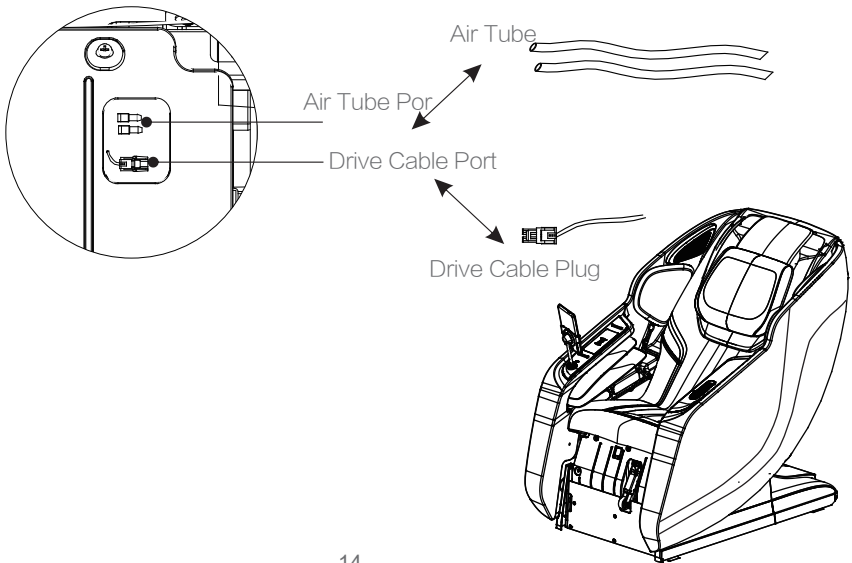

## 03Pre-Use Preparation

- ▶ Align the calf mounting ears with the left and right rotating shafts on the seat frame, secure them with locking clips, then fasten the zippers on both the calf cover and drape cover.

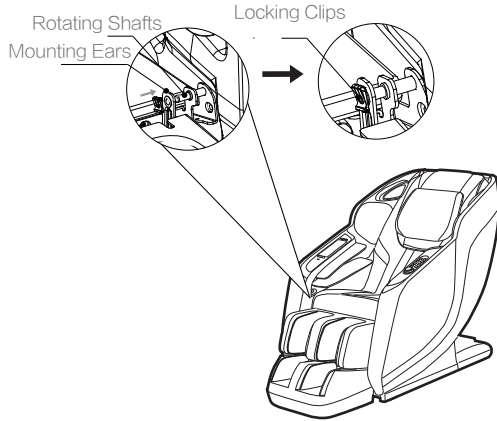

### Step 3: Controller Installation

- ▶ Connect the controller's data plug to the corresponding socket on the upper-right side of the armrest frame, ensuring proper alignment of the guide marks (dot-to-dot).

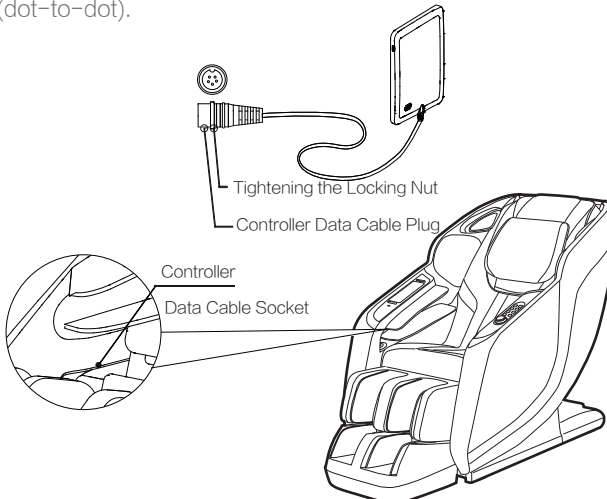

# 03 Pre-Use Preparation

## Step 4: Tablet Holder Installation

- ▶ Insert the tablet holder into the module on the right armrest of the massage chair and securely tighten the locking nut. (Note : The holder should initially face towards the rear of the chair, but can be adjusted to the user's preferred orientation after installation.)

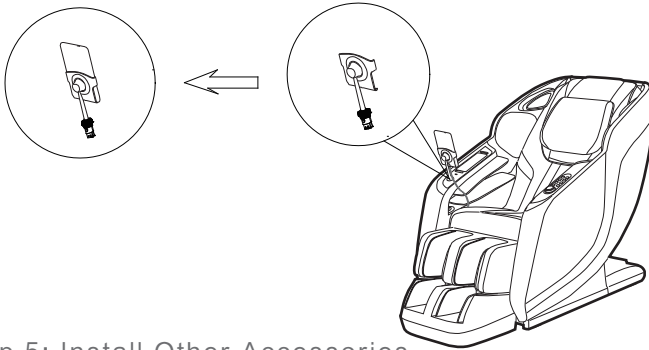

## Step 5: Install Other Accessories

- ▶ Align and connect the power cord plug to the power box socket until it clicks in to place (refer to diagram).

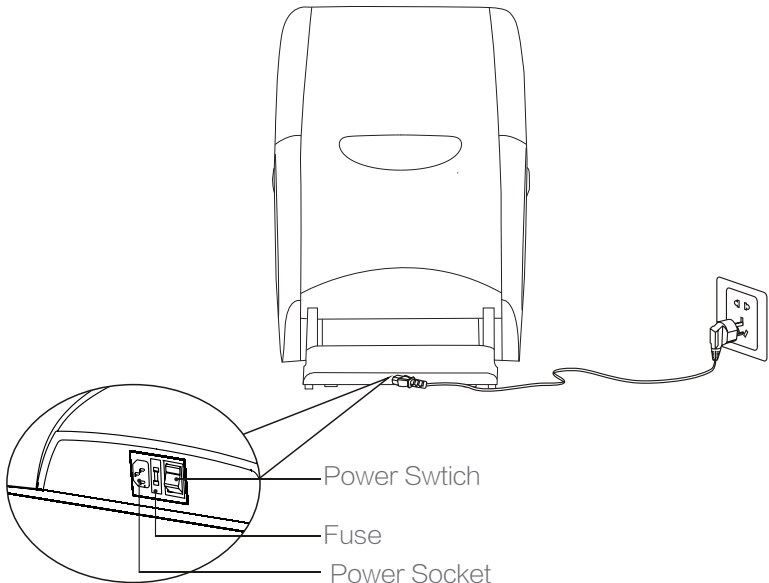

# 03 Pre–Use Preparation

## Moving the Massage Chair

- ▶ Roll the chair on its casters to the desired location.
- ▶ Incline the backrest to upright position.
- ▶ Turn off the power switch and unplug the appliance from the electrical outlet.
- ▶ Using two people,push down on the backrest and lift up on the front sides,roll the chair on its casters to the desired location(check the sketch for reference).

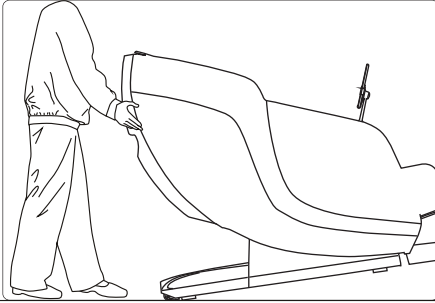

### CAUTION

- ▶ Do not move the chair while The user sits inside.
- ▶ To carry this product, do not lift by the footrest or armrest,hold the base and steady the backrest(have 4 or more people to carry the product).

## Connecting to Power

- ▶ Connect this appliance to a 3-wire properly grounded outlet.
- ▶ Turn on the main power switch located at the power box of the product.

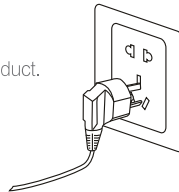

### CAUTION

- ▶ Please verify that there is no damage to the supply cord before switching on the massage chair.
- ▶ Please verify that the main power switch is turned off before connecting to power.

# 03Pre–Use Preparation

---

## Commissioning

- ▶ Use the controller to recline the backrest to its lowest position,raise and extend the footrest to its top position, make sure there is enough clearance before commissioning.
- ▶ Return the backrest and footrest back to its default position after commissioning and turn off the power switch.(To choose the massage program, please check the Controller Instructions for reference)

## Before Sitting in the Chair

- ▶ Ensure the footrest is well assembled before sitting on the massage chair.
- ▶ Ensure the massage chair is returned to its original position before sitting on it.  
If there is any part not in default position,please turn on the massage chair to allow it to restore.



### CAUTION

- ▶ Do not take seat while the legrest is lifted.
- ▶ Do not put excessive load on the legrest to avoid damage.



### WARNING

- ▶ Do not play on the massage chair or operate it improperly.
- ▶ Ensure there is no obstruction when raising or reclining the backrest and footrest.
- ▶ Do not put foot,fingers or any other objects in the openings of the chair when it is in the reclining, raising or restoring motion.
- ▶ Ensure that massage chair is restored back to its original position before getting off the massage chair.

## After Use

- ▶ Always unplug the massage chair from the electrical outlet immediately after use.
- ▶ Turn off the power switch and unplug the massage chair from the electrical outlet while not in use to avoid children power on the massage chair accidentally.
- ▶ When not in use for a long period of time,we recommend that the chair be covered, the power cord be coiled and that the unit be placed in an environment free of dust and moisture.

# 04 Maintenance&Storage

## Care Instructions

- ▶ To treat stains on the back panel,armrest,footrest,plastic parts or air hose,spot clean with mild detergent foam,then wipe it with a dry cleaning cloth.
- ▶ To treat stains on the controller,power box,spot clean with a dry cleaning cloth.
- ▶ To treat stains on the back cushion or pillows,use a water-based upholstery cleaner only,wipe it with moist cloth,then air dry.
- ▶ To clean the foot / leg unit covers,remove it from the chair,hand wash with a mild detergent,then line dry.



### WARNING

- ▶ Pull out the power cord from the power strips before care and maintenance.  
To avoid electrical shock or injury,do not touch the power cord with wet hands.  
Make sure no detergent enter into the power box while cleaning.
- ▶ Do not use benzene,thinner or other solvents on your product,it may cause fading or damage to the product.
- ▶ Do not iron the upholstery.

## Storage Methods

- ▶ Cover the product with a dust-free cloth to prevent the collection of dust if not in use of a long period of time.



### CAUTION

- ▶ Do not leave this product exposed to direct sunlight for long periods of time. This may cause fading or damage.

## Warm Tips

During daily use, please check for the following symptoms:

- ▶ Burnt smell.
- ▶ Power flickers on and off when touching the charging cable.
- ▶ The power cord is hot.
- ▶ Other abnormal symptoms.



### CAUTION

- ▶ Please stop using the product to avoid breakdowns or accidents if any above symptom exists.
- ▶ Switch off the power button and disconnect the plug,contact us or the dealer for repair.
- ▶ All other servicing except above care and maintenance should be serviced by an authorized dealer or service center.



### WARNING

- ▶ Pull out the power cord from the power strips before care and maintenance.
- ▶ To avoid electrical shock or injury,do not touch the power cord with wet hands.
- ▶ Do not try to dismantle or repair the product yourself,please send your massage chair to the authorized service center.

# 05 Troubleshooting

No.	Symptoms	Possible Causes	Possible Solutions
1	Noise is heard while in use	This sound is normal and comes from the air compressor motor or other mechanical parts rubbing against the cloth cover	No need to take any measures
2	Appliance does not start	The power cord is not secured into the socket	Secure it into a well-functioned electrical outlet
		Power Switch is off	Turn on the switch
		The fuse is blown	Replace only with a fuse of same type and rating
3	No music comes from the speaker	The volume is turned to the lowest	Adjust the speaker volume from the mobile devices
		Bluetooth didn't connect with music device	Reconnect Bluetooth
4	Backrest or footrest can not raise or recline	Excessive load has been pressed on the backrest or legrest	Reduce the load and try again
5	Airbag malfunction	The air hose is blocked	Straighten the air hose and clear out the blockage

If problem remains, please contact us or authorized service center for maintenance.

**Important:** Do not attempt to repair this product yourself, our company shall not be liable for the injury or damage caused by any servicing without authorization

# 06 Technical Specifications

---

Product Name: Osaki 4D Helix LE Massage Chair

Model Number: 4D Helix LE

Rated Voltage: 110-120V~

Rated Frequency: 60Hz

Rated Current: 1.3A

