

OCEAN[®]

RIGGING HARDWARE & PRODUCTS

LEVER CHAIN HOISTS

Reliable Hoists, Clamps, and Trolleys
for Everyday Lifting Applications



ALTERED STOCK PHOTO FOR ILLUSTRATIVE PURPOSES ONLY. NOT ACTUAL PRODUCT.

Authorized Distributor



Shop Ocean[®] Products on [Lifting.com](https://www.lifting.com)

Engineered to perform —
day after day.



ALTERED STOCK PHOTO FOR ILLUSTRATIVE
PURPOSES ONLY. NOT ACTUAL PRODUCT.



OCEAN[®] LEVER CHAIN HOIST

RELIABLE MANUAL LIFTING

ENGINEERED FOR EVERYDAY WORK

COMPACT AND DURABLE CONSTRUCTION WITH HIGH-STRENGTH STEEL FRAME

Long-term reliability and high load-bearing capability.

CORROSION-RESISTANT BODY

Long service life even in harsh environments.

BLACK ELECTROPHORESIS G80 CHAIN

Reliable lifting with enhanced corrosion resistance

PRECISION GEAR MECHANISM

Smooth, controlled lifting and lowering with reduced manual effort.

HEAT TREATED ALLOY STEEL HOOKS WITH SAFETY LATCHES

Swivel design prevents twisting and ensures safe, easy load attachment.

BONDED BRAKE ASSEMBLY

Stable performance, reduced wear, consistent load control in all working conditions.

OVERLOAD PROTECTION

Prevents accidental overloading, protecting both user and hoist mechanism.

BRAKE SEAT AND DRIVING SHAFT CONNECTED BY INVOLUTE SPLINES

Strong braking performance and easy disassembly.

COMPACT AND HIGHER STRENGTH LEVER

Enhanced maneuverability in confined spaces.

ERGONOMIC RUBBER GRIP

Designed for operator comfort and secure handling during prolonged use.

FREEWHEEL FUNCTION

Allows quick load chain adjustment for fast setup and efficient operation.

TESTED TO ANSI/ASME STANDARDS

Engineered for reliability in North America market.

CAPACITY 0.8-9 TON OPTIONS

Suited for general use and everyday applications.



OCEAN[®] LEVER CHAIN HOIST MODELS

RELIABLE MANUAL LIFTING ENGINEERED FOR EVERYDAY DEMANDS

The Ocean[®] Lever Hoist is built for versatility and control – the tool professionals trust when every inch counts. Designed for rigging, positioning, and load-securing in the field, it delivers dependable performance with minimal

effort. Its ergonomic design, advanced braking system, and anti-corrosion protection make it the perfect partner for industrial, construction, and maintenance applications.

Steel Construction

Overload Protection

ASME Compliant

ANSI Compliant

Chain Lengths: 5', 10', 15', 20', No Chain

Certifications: ANSI / ASME

Country of Origin: China

Color: Yellow

Power: Manual

Warranty: 2 yrs

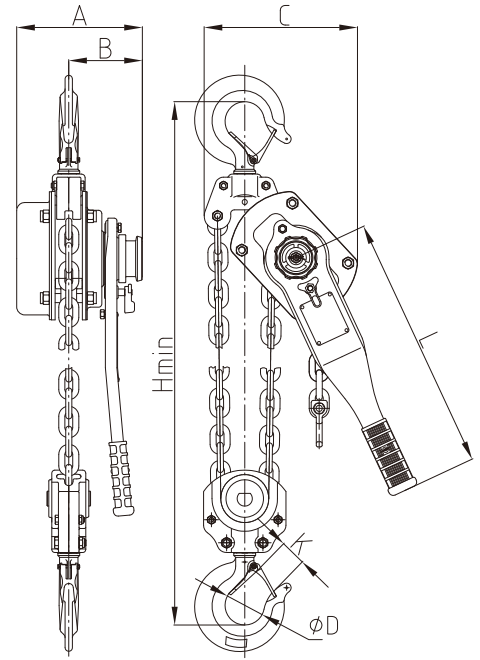

Ocean [®] Brand Lever Hoist Capacities (tons)		0.8T	1.6T	3.2T	6.3T	9.0T
MODEL		OCN-LH0.8	OCN-LH1.6	OCN-LH3.2	OCN-LH6.3	OCN-LH9.0
CAPACITY (lbs.)		1700	3500	7000	13800	19800
Dimensions (in.)	A	6.3	7.71	8.17	8.19	8.17
	B	3.94	4.29	4.8	4.8	4.8
	C	5.27	6.18	8.27	9.96	13.31
	D	1.57	1.77	2.17	2.68	3.35
	H-MIN	12.6	14.37	19.29	22.83	32.68
	L	9.84	10.63	16.93	16.93	16.93
	K	1.02	1.14	1.54	1.69	2.28
NET WEIGHT (with 10' of chain)		15.65	23.81	51.37	78.48	92.37
LOAD CHAIN (mm)		6x18	8x24	10x30	10x30	10x30
STRANDS OF LOAD CHAIN (#)		1	1	1	2	3
STRANDS LIFT		Depends on selected chain length: No Chain, 5 ft. 10 ft., 15 ft., or 20 ft.				
EFFORT REQUIRED TO LIFT RATED LOAD (lbf.)		44.96	79.81	75.31	78.68	72.61
SKU by Chain Length	NO CHAIN	OCN-LH0.8-NC	OCN-LH1.6-NC	OCN-LH3.2-NC	OCN-LH6.3-NC	OCN-LH9.0-NC
	5' CHAIN	OCN-LH0.8-05	OCN-LH1.6-05	OCN-LH3.2-05	OCN-LH6.3-05	OCN-LH9.0-05
	10' CHAIN	OCN-LH0.8-10	OCN-LH1.6-10	OCN-LH3.2-10	OCN-LH6.3-10	OCN-LH9.0-10
	15' CHAIN	OCN-LH0.8-15	OCN-LH1.6-15	OCN-LH3.2-15	OCN-LH6.3-15	OCN-LH9.0-15
	20' CHAIN	OCN-LH0.8-20	OCN-LH1.6-20	OCN-LH3.2-20	OCN-LH6.3-20	OCN-LH9.0-20

MODEL OCN-LH0.8 SPECIFICATIONS

0.8T Ton Ocean® Lever
Chain Hoist Chain Lengths

	5FT.	10FT.	15FT.	20FT	NO CHAIN
SKU	OCN-LH0.8-05	OCN-LH0.8-10	OCN-LH0.8-15	OCN-LH0.8-20	OCN-LH0.8-NC
STRANDS LIFT (ft.)	5	10	15	20	N/A

Load Chain (mm): 6x18
Strands of Load Chain (#): 1
**Effort Required to Lift
 Rated Load (lbf.):** 44.96
Country of Origin: China

Certifications: ANSI / ASME
Warranty: 2 yrs
Color: Yellow
Power: Manual
Overload Protection: Included
Net Weight: 15.65 (with 10' of chain)

DIMENSIONS (in.)

A: 6.30
B: 3.94
C: 5.27
D: 1.57
H-Min: 12.60
L: 9.84
K: 1.02
Capacity (lbs.): 1,700

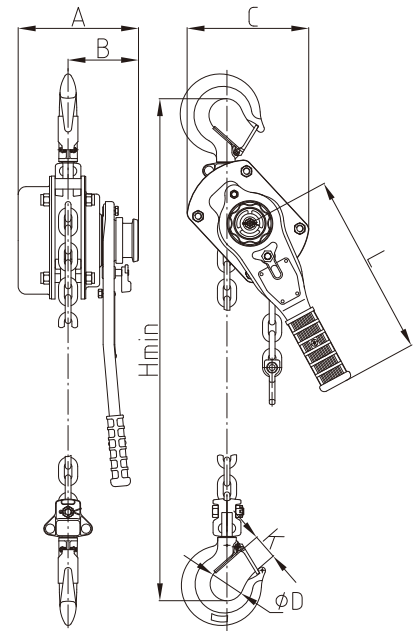

MODEL OCN-LH1.6 SPECIFICATIONS

1.6T Ton Ocean® Lever
Chain Hoist Chain Lengths

	5FT.	10FT.	15FT.	20FT	NO CHAIN
SKU	OCN-LH1.6-05	OCN-LH1.6-10	OCN-LH1.6-15	OCN-LH1.6-20	OCN-LH1.6-NC
STRANDS LIFT (ft.)	5	10	15	20	N/A

Load Chain (mm): 8x24
Strands of Load Chain (#): 1
**Effort Required to Lift
 Rated Load (lbf.):** 79.81
Country of Origin: China

Certifications: ANSI / ASME
Warranty: 2 yrs
Color: Yellow
Power: Manual
Overload Protection: Included
Net Weight: 23.81 (with 10' of chain)

DIMENSIONS (in.)

A: 7.71
B: 4.29
C: 6.18
D: 1.77
H-Min: 14.37
L: 10.63
K: 1.14
Capacity (lbs.): 3,500

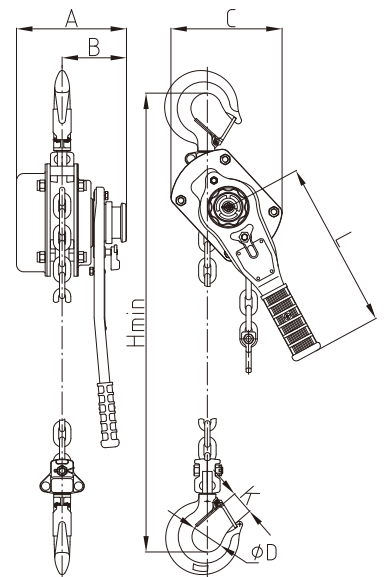

MODEL OCN-LH3.2 SPECIFICATIONS

3.2T Ton Ocean® Lever Chain Hoist Chain Lengths	5FT.	10FT.	15FT.	20FT	NO CHAIN
SKU	OCN-LH3.2-05	OCN-LH3.2-10	OCN-LH3.2-15	OCN-LH3.2-20	OCN-LH3.2-NC
STRANDS LIFT (ft.)	5	10	15	20	N/A
Load Chain (mm): 10x30 Strands of Load Chain (#): 1 Effort Required to Lift Rated Load (lbf.): 75.31 Country of Origin: China		Certifications: ANSI / ASME Warranty: 2 yrs Color: Yellow Power: Manual Overload Protection: Included Net Weight: 51.37 (with 10' of chain)			
DIMENSIONS (in.) A: 8.17 B: 4.80 C: 8.27 D: 2.17		H-Min: 19.29 L: 16.93 K: 1.54 Capacity (lbs.): 7,000			

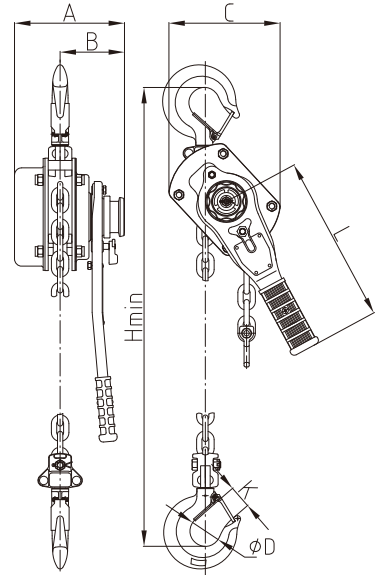

MODEL OCN-LH6.3 SPECIFICATIONS

6.3T Ton Ocean® Lever Chain Hoist Chain Lengths	5FT.	10FT.	15FT.	20FT	NO CHAIN
SKU	OCN-LH6.3-05	OCN-LH6.3-10	OCN-LH6.3-15	OCN-LH6.3-20	OCN-LH6.3-NC
STRANDS LIFT (ft.)	5	10	15	20	N/A
Load Chain (mm): 10x30 Strands of Load Chain (#): 2 Effort Required to Lift Rated Load (lbf.): 78.68 Country of Origin: China		Certifications: ANSI / ASME Warranty: 2 yrs Color: Yellow Power: Manual Overload Protection: Included Net Weight: 78.48 (with 10' of chain)			
DIMENSIONS (in.) A: 8.19 B: 4.80 C: 9.96 D: 2.68		H-Min: 22.83 L: 16.93 K: 1.69 Capacity (lbs.): 13,800			

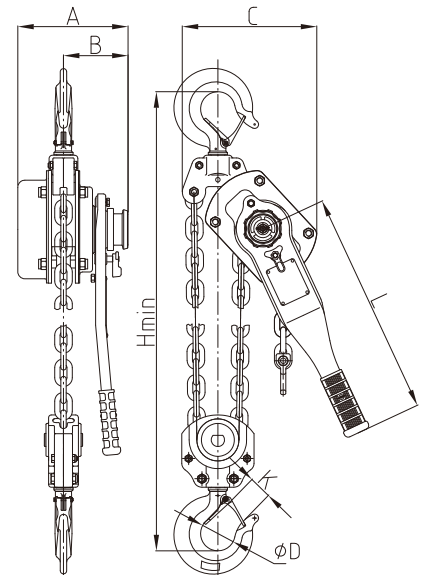

MODEL OCN-LH9.0 SPECIFICATIONS

9.0T Ton Ocean® Lever
Chain Hoist Chain Lengths

	5FT.	10FT.	15FT.	20FT	NO CHAIN
SKU	OCN-LH9.0-05	OCN-LH9.0-10	OCN-LH9.0-15	OCN-LH9.0-20	OCN-LH9.0-NC
STRANDS LIFT (ft.)	5	10	15	20	N/A

Load Chain (mm): 10x30

Strands of Load Chain (#): 3

Effort Required to Lift

Rated Load (lbf.): 72.61

Country of Origin: China

Certifications: ANSI / ASME

Warranty: 2 yrs

Color: Yellow

Power: Manual

Overload Protection: Included

Net Weight: 92.37 (with 10' of chain)

DIMENSIONS (in.)

A: 8.17

B: 4.80

C: 13.31

D: 3.35

H-Min: 32.68

L: 16.93

K: 2.28

Capacity (lbs.): 19,800

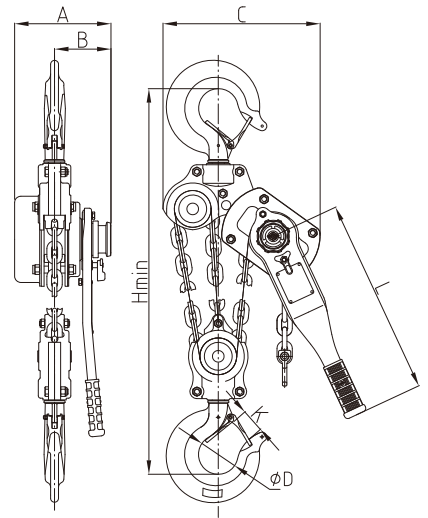

OCEAN® RIGGING HARDWARE & PRODUCTS - SOLVE YOUR EVERYDAY LIFTING NEEDS

Designed to perform where others fail, Ocean® combines rugged durability with operator comfort. With industry-leading corrosion resistance and safety built into every detail, Ocean Hoists are the trusted choice for teams that demand more from their lifting equipment.

Visit oceanproducts.com or contact your local Bishop Lifting representative for more information and product details!

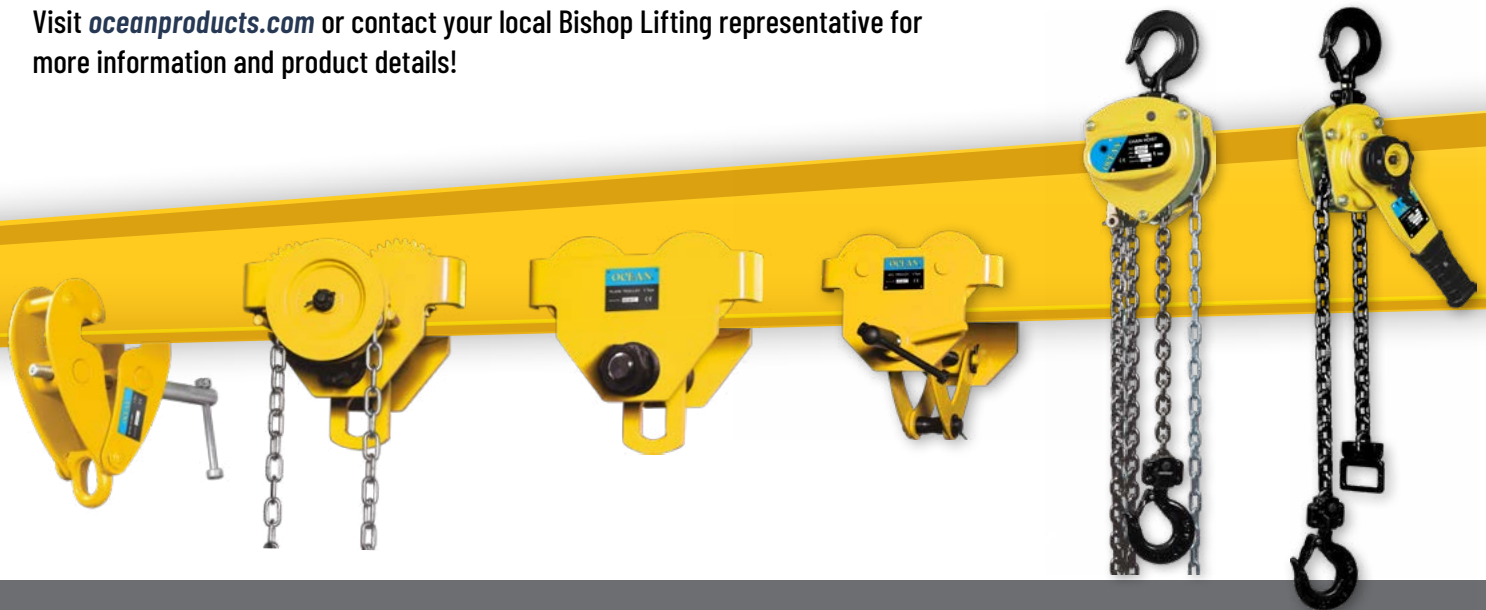

OCEAN[®] LEVER CHAIN HOISTS

Ocean[®] Chain Hoists are available in multiple capacities and lift lengths, making them versatile for construction, industrial maintenance, marine, and logistics applications. Featuring anti-corrosive chains, reinforced body protection and overload safety, Ocean Hoists ensure dependable performance where strength and safety matter most.



INTEGRATED MECHANICAL OVERLOAD PROTECTION

Prevents damage caused by excessive loading, ensuring product and operator safety.

BLACK ELECTROPHORESIS 680 CHAIN

Enhanced resistance to corrosion and reliable lifting performance.

ANTI-CORROSION FINISHES

Superior lifespan in humid or outdoor environments.

HIGH-STRENGTH STEEL BODY AND GEAR HOUSING

Exceptional durability and long service life, even under heavy-duty use.

TESTED TO ANSI/ASME STANDARDS

Engineered for reliability in North America market.

BUILT TO LIFT. BUILT TO LAST.

**BISHOP
LIFTING**

OPERATING, MAINTENANCE & PARTS MANUAL

OCEAN® LEVER HOIST

For lever hoist in capacities 0.8 ton through 9 ton

These Lever Hoist Models meet or exceed the following standards:



AS1418.2

ANSI B30.21

ANSI B30.16

Plus:



IF YOUR HOIST WILL NOT ACTIVATE

We commonly see this occur when the overload protection has engaged, signaling your load is heavier than the hoist is rated for. Check hoist capacity against load weight.

Before using the hoist, fill in the information below:

Capacity: _____

Model No.: _____

Serial No.: _____

Date: _____



CONTENTS

General Information **4**

Hoist Construction

Terms & Summary

Inspection Before Initial Use **5**

Installation

Operation

To Avoid Injury: Do's & Don'ts **5**

Safety Information **6**

Signal Words – Danger, Warning,
Caution & Notice

Warning Tag 7

Safety Rules 7

Inspection & Maintenance Schedule **8**

Inspection Chart

Hooks 9

Hook Inspection 9

Inspections **10**

Schedule

Frequent Inspection

Periodic Inspection

Exceptions

Chain

Hooks 11

Lubrication **11**

General

Gears

Chain 12

Overload Protection **12**

Dimensions & Specifications **13**

Parts List & Exploded View **14**

Service Notes & Log **15**

Ocean© Hoist Warranty **16**

Warranty Coverage

Warranty Claim Procedure

GENERAL INFORMATION

This document provides information and maintenance of Ocean® Hand Chain Hoists. People who are operating or maintaining the hoist should be familiar with this manual. Following the precautions, procedures and maintenance practices in this manual should ensure long and reliable operation. People responsible for the installation, operation, and/or maintenance of the this hoist should be familiar with the American National Standard ANSI B30.16 for guidelines on the safe operation of hoists.

This document and ANSI B30.16 must be read and understood by all individuals before they install, operate or maintain this equipment.

HOIST CONSTRUCTION

This hand chain hoist is an efficient means of lifting freely suspended material loads within its load rating. This chain hoist's construction conforms to applicable ANSI B30.16 guidelines and is built to withstand stresses imposed under normal operating conditions while handling loads within its load rating. The frame and covers of the hoist are made from stamped steel construction. The cast hand chain wheel and load activated break will provide smooth, precise spotting of loads.

TERMS & SUMMARY

This manual provides important information for personnel involved with the installation, operation, and maintenance of the hoist. It is the responsibility of the owner/user to install, inspect, test, maintain an operate this hoist in accordance with applicable ANSI standards.

These general instructions deal with the normal operation and maintenance situations encountered with the products described herein.

This product should not be installed, operated or maintained by any person who has not read all of the contents of these instructions. Failure to read and comply with these instructions or any of the warnings or limitations noted herein can result in serious bodily injury or death, and/or property damage.

Only trained and qualified personnel shall operate and maintain this equipment.

Equipment described herein is not designed for, and shall not be used for lifting, supporting or transporting people.

Modifications to up-grade, re-rate or otherwise alter these products can only be authorized by the manufacturer.

INSPECTION BEFORE INITIAL USE

After unpacking the hoist, inspect carefully for any damage that may have occurred during shipping. Check for loose, missing or damaged parts.



DO NOT install or use a damaged product.

Before initial use record the Capacity, Model, Serial Number and Date of Purchase in the space provided on the front cover of this manual.

INSTALLATION

Be sure that the hoist is suspended or connected to a supporting structure that is strong enough to support the full rated load of the hoist using a generous factor of safety. The hoist body must be allowed to freely align itself between the two hooks. The load path, or path of force, between the top hook and the bottom hook must be in a straight line and shall not be deflected or bent. Do not allow any part of the hoist frame/body to rest against or make contact with any object or supporting structure.



TO AVOID INJURY: DO'S & DON'TS

- A. READ these instructions and relevant ANSI Standards before installing, operating, or maintaining this equipment.
- B. WARN personnel of approaching loads.
- C. **DO NOT, WHERE APPLICABLE:**
Lift more the rated load.

OPERATION

Before Initial Operation:

Read and comply with all instructions and warnings furnished with or attached to the product if applicable.

Check lubricant.

Check operation of brake.

Where applicable, check that chain is properly seated in sheaves and that chain is not twisted, kinked or damaged.

Before Each Shift, Where Applicable:

Inspect hooks for nicks, gouges, cracks, and signs of pulling apart or twisting.

Inspect hook latch for proper operation.

Check chain for kinks or twists.

Check operation of brake.

Replace warning label if missing or illegible.

Before Operating:

Be certain all personnel are clear of the load to be lifted and moved.

Make sure load will clear stock piles, machinery, or other obstructions when hoisting and travelling the load.

Operate unless load is properly applied to the saddle or bowl of the hook.
Operate if load is applied to the tip of the hook.
Operate with damaged or missing hook latches.
Lift people or lift loads over people.
Operate with side-pulling or side-loading of load to hoist.
Operate a damaged or malfunctioning product.

Operate with other than hand power.
Remove, deface, or obscure warning label or labels.
Leave load suspended if unattended, unless specific precautions have been instituted.
Lengthen load chain or repair damaged load chain by welding.
Use chain as a ground for welding

SAFETY INFORMATION

It is the responsibility of the owner/user to install, inspect, test, maintain, and operate these products in accordance with ANSI standards.

These general instructions deal with the normal installation, operation and maintenance situations encountered with the products described herein.

This product should not be installed, operated or maintained by any person who has not read all the contents of these instructions. Failure to read and comply with these instructions or any of the warnings or limitations noted herein can result in serious bodily injury or death, and/or property damage.

Only trained and qualified personnel shall operate and maintain this equipment.

Equipment described herein is not designed for, and should not be used for lifting, supporting or transporting people.

Modifications to up-grade, re-rate or otherwise alter these products can only be authorized by the manufacturer.

SIGNAL WORDS – DANGER, WARNING, CAUTION & NOTICE

Throughout this manual, there are steps and procedures that can present hazardous

situations. The following signal words are used to identify the degree or level of hazard seriousness.

DANGER indicates an imminently hazardous situation which, if not avoided, will result in death or serious injury and property damage.

WARNING indicates an imminently hazardous situation which, if not avoided, could result in death or serious injury and property damage.

CAUTION indicates a potentially hazardous situation which, if not avoided, may result in minor or moderate injury or property damage.

NOTICE is used to notify people of installation, operation or maintenance information which is important but not directly hazard related.



These general instructions deal with the normal installation, operation, and maintenance situations encountered with the hoists referenced in this manual. The instructions should not be interpreted to anticipate every possible contingency or to anticipate the final system, crane, or configuration that uses this hoist. For systems using a hoist in this manual, the supplier and owner of the system are responsible for the system's compliance

with all applicable industry standards, and with all applicable federal, state and local regulations/codes.

WARNING TAG

Ocean[®] hoists are supplied from the factory with a warning label as depicted in Figure 1.

Operators are to read and obey all warnings.

This label is to remain on the hoist and legible at all times.

Replacement label can be supplied by your Ocean[®] distributor.



Figure 1

SAFETY RULES

Inspect the hoist for loose, broken or malfunctioning parts. Any hoist should be tagged “out of order” and taken out of service until the problem is corrected.

DO NOT overload the hoist.

DO NOT side load the hoist. Make sure to pull in the straight line between hooks. Side loading the hoist over a sharp corner may fracture the hoist housing, load block or hook.

Be sure there are **NO** twists in the chain. Make sure that the load chain is free to move and clear all obstructions. With multiple chained hoists the load hook can be turned one or more times causing the chain to twist.

DO NOT use the hoist from an unbalanced/unstable position. Operators should have firm footing or be secured before operating the hoist.

Before raising and/or pulling a load always make sure that the slings and other rigging have sufficient capacity to support the load, and are in good condition.



DO NOT STAND BENEATH A SUSPENDED LOAD OR WALK UNDER A SUSPENDED LOAD!

DO NOT operate a load in a way to endanger personnel.

DO NOT leave the hoist with a suspended load.

DO NOT wrap the load chain around the load. **USE A SLING!**

DO NOT TIP-LOAD the hook, as this will exert undue strain, resulting in hook failure.

The hoist is designed for manual operation by one person only. **DO NOT** operate the hoist with other power besides the manual power from one person. (See Table 1 for each hoist's rated effort/force to raise capacity loads.)



DO NOT USE THIS HOIST TO LIFT, SUPPORT OR OTHERWISE TRANSPORT PEOPLE OR LIFT LOADS OVER PEOPLE.

The hand chain has at least one safety connector link. When any safety connector link opens or deforms, stop immediately to find out the cause.

NEVER use the chain or hook as a ground welding.

Use only Ocean[®] original replacement parts and chains supplied by an authorized Ocean[®] dealer. **NEVER** intentionally lower the hoist load chain out/down so-as to force tension on the lower limit stop device.

INSPECTION & MAINTENANCE SCHEDULE

Prior to initial use, all new, modified and repaired products shall be inspected in accordance with Table 1. Thereafter, items to be inspected are indicated in Table 1 by F (*Frequent*) or P (*Periodic*).

Frequent Inspections: Visual inspection by the operator or other authorized person. This inspection includes listening for unusual sounds while the product is operated that may indicate deficiencies.

Periodic Inspections: Audible-visual inspection as for Frequent Inspections, with some disassembly to allow a more detailed inspection if external conditions indicate the need.

Exception: Brakes require more than audible-visual inspection. Check daily by operating the product with and without load, stopping at various positions to ensure safe operation.

You're almost there — send the next screenshot and we'll keep sprinting to the finish line.

INSPECTION CHART

ITEM	LOCATION	CHECK / INSPECT FOR	F	P
Braking Mechanism		Slipping under load; jumping; jolting	x	
		Hard or difficult to release	x	
Brake Discs		Glazing; cracks; crushing; deformation; thickness		x
		Oil contamination; chemical contamination		x
Brake Parts	Pawl - Ratchet	Excessive wear; deformation; fit; corrosion		x
	Pawl - Spring	Stretch; deformation; corrosion		x
Hooks – Top & Bottom		Chemical damage; corrosion; welding arcs	x	
		Deformation; gouging; heat damage	x	
		Cracks: use dye penetrant, magnetic particle or other suitable detection method		x
Hook Retaining Members – Pins, bolts, nuts		Not tight or secure		x
Hook Latch		Damage; deformation; does not close	x	
Suspension Members – Sheaves, hand-wheels, chain attachments, suspension bolts		Excessive wear; looseness, deformations		x
		Cracks; breaks	x	x
Gears		Distortion		x
		Broken or worn teeth		x
		Cracks		x
		Inadequate lubrication		x
Load Block – Suspension Housing		Distortion	x	
		Cracks; accumulation of foreign deposits; wear; damage; missing or loose parts	x	x
Trolley – Supporting structure		Possible inability to support rated loads		x
Bolts, Nuts, Rivets, hardwareH		Not tight or secure		x
WARNING Label		Present and legible	x	

HOOKS



WARNING

Any hook that requires replacement because of excessive bends, twists, or throat opening indicates abuse or overloading of the product. Therefore, other load-supporting components of the product should be inspected for possible damage when such conditions are found.

Never repair hooks by welding or reshaping. Heat applied to the hook will alter the original heat treatment of the hook material and reduce the strength of the hook.

Never weld handles or other attachments to the hook.

HOOK INSPECTION

Where applicable, inspect hooks and measure throat opening at least once a month. Between regular inspections check visually daily for deformation, distortion, twisting, damage and missing or damaged hook latches.

Hooks damaged from chemicals, deformations or cracks, or that have more than 10° twist from the plane of the unbent hook or excessive opening or seat wear, must be replaced. Also, hooks that are opened to the extent that the latch does not engage the tip must be replaced. See figures 1 and 2.

Note: Top and Bottom Hooks have same dimensions.

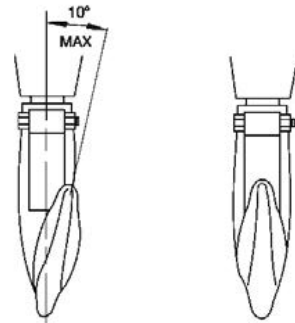

Figure 1

Hook Opening:

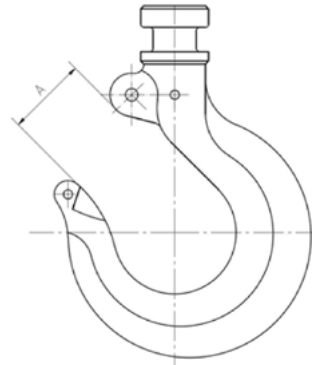

Figure 2

REPLACE HOOK WHEN OPENING IS GREATER THAN	HOIST CAPACITY (TONS)
1.07in (27.3mm)	0.8
0.99in (25.2mm)	1.6
1.57in (39.9mm)	3.2
1.81in (46.2mm)	6.3
2.65in (67.2mm)	9.0

INSPECTIONS

SCHEDULE

Frequent and periodic inspections are thorough examinations conducted by personnel trained in the safety, operation and maintenance of this equipment. ASME B30.16 states inspection intervals depend upon the nature of the critical components of the equipment and severity of usage.

Careful inspection on a regular basis will reveal potentially dangerous conditions while still in the early stages, allowing corrective action to be taken before the condition becomes dangerous.

Deficiencies revealed through inspection, or noted during operation, must and shall be reported to designated personnel trained in safety, operation and maintenance of this equipment.

A determination as to whether a condition constitutes a safety hazard must be decided, and the correction of noted safety hazards accomplished and documented by written report before placing the equipment in service.

Prior to initial use, all new, modified and repaired products shall be inspected in accordance with all items in Table 2. Thereafter, items to be inspected are indicated in Table 2 by Frequent or Periodic designation.

FREQUENT INSPECTION

On a hoist in continuous service, frequent inspections should be conducted at the beginning of each shift. In addition, visual inspections should also be conducted during regular service for any damage or evidence of malfunction which appears between regular inspections. This inspection includes listening for unusual sounds while the product is being operated that may indicate deficiencies.

PERIODIC INSPECTION

Frequency of periodic inspection depends on the severity of usage:

Normal Usage – Annually

Heavy Usage – Semiannually

Severe Usage – Quarterly

Audible coupled with visual inspection according to the items listed in Frequent designation. Some disassembly is required to allow a more detailed inspection if external conditions indicate the need.

EXCEPTIONS

Brakes require more than audible / visual inspection. Check daily by operating the product with and without a load, stopping at various positions to ensure safe operation.

CHAIN

Inspect chain before each use. Between regular inspections, check visually daily for nicks, gouges, weld splatter, corrosion, or distorted links. Inspect chain thoroughly if it does not feed smoothly over load sheaves.



Figure 2

Inspect as follows:

Clean chain before inspection.

Test hoist with load and observe operation of chain as it passes over load sheaves

Slacken chain and inspect contact points for excessive wear.

See Figure 7

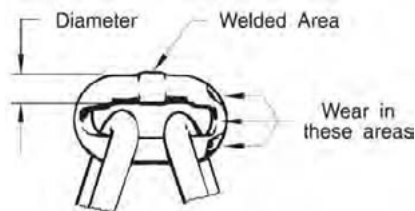

Figure 7

HOOKS

Any hook that requires replacement because of excessive bends, twists, or throat opening indicates abuse or overloading the hoist.

Therefore, other load supporting components of the hoist should be inspected for possible damage when such conditions are found.

Never repair hooks. Never weld or reshape a hook. Never heat a hook. Heat applied

to the hook will alter the original heat treatment of the hook material and reduce the strength of the hook.

Never weld handles or other attachments to the hook.

Hook Inspection:

Where applicable, inspect hooks and measure throat opening at least once per month.

Between regular inspections check visually daily for deformation, distortion, twisting, damage, and missing or damaged hook latches.

Hooks damaged from chemicals, deformations or cracks, or that have more than 10 degree twist from the plane of an unbent hook or excessive opening or seat wear, must be replaced. (See Figure 5)

Also, hooks that are opened to the extent that the latch does not engage the tip must be replaced. (See Figure 6 and Table 3 for hook retirement/replacement criteria)

LUBRICATION

All internal operating parts of an Ocean[®] hand chain hoist that require lubrication are pre-lubricated at the time of assembly by the factory. Re-lubrication is recommended at intervals according to Periodic Inspection. However, re-lubrication may be required more frequently based on type and severity of service.

GENERAL

The use of anti-seize compound (***) is recommended on internal threaded components. Unless otherwise stated, remove old lubricant, clean the part with an acid free solvent and apply a new coating of lubricant to the part before assembly. Lubricant should cover all necessary surfaces evenly without gaps in coverage.

Do not apply lubricant to brake friction disk or brake surfaces. Do not allow excess lubricant to make contact with the brake friction disk or brake surfaces.

The brake surfaces must be kept free of any trace of oil, grease or lubricant. Apply lubricant to parts near the brake neatly, evenly and in measured amounts. Keep the lubricant localized on the part being lubricated to avoid contamination of the brake and brake surfaces. (adjacent text to caution box)

GEARS

Unscrew nuts in the opposite side of the hoist as the hand chain, and remove gear cover and support plate. Remove old grease and replace with new. For hoist operating in temperatures from -20 degrees to 50 degrees Fahrenheit; use

EP1 grease or equivalent. For hoists operating in temperatures from 30 degrees to 120 degrees Fahrenheit use EP2 grease or equivalent.

CHAIN

Lubricate each link of the load chain weekly. Work lubricant into the area where the links contact each other. Apply new lubricant over existing layer.

In severe usage applications, aggressive or corrosive environments, lubricate more frequently than normal.

Lubricate hook and hook latch pivot points with the same lubricant used on the load chain.

Do not apply lubricant to the hand chain.

To remove rust or abrasive dust build-up. Clean chain with acid free solvent. After cleaning, lubricate the chain.

Use SAE 50 to 90EP oil.

** Recommend – Loctite® Nickel-Based High Performance N-5000™ High Purity Anti-Seize paste.

OVERLOAD PROTECTION

You have purchased an Ocean® hand chain hoist fitted with overload protection. The following information should be read in conjunction with all other information contained in this manual;

The "Load Safe" overload protection consist of the components shown as sub-parts of part #19-1 in the exploded view of the product.

The overload protection is calibrated at the time of manufacture and should not require re-calibration if the hoist is used as intended.

The overload clutch can be re-calibrated using factory supplied tools available only to Ocean® repair agents.

In the unlikely event of the overload clutch being damaged, complete replacement kits are available. Individual clutch components are NOT available.

DIMENSIONS & SPECIFICATIONS

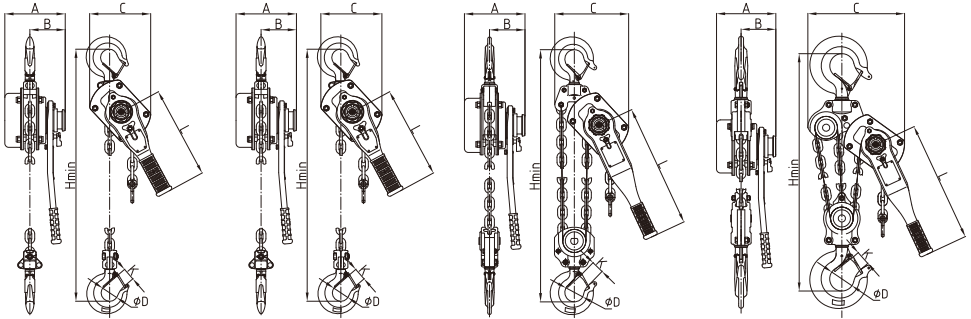

Ocean® Brand Lever Hoist Capacities (tons)

	0.8T	1.6T	3.2T	6.3T	9.0T
--	------	------	------	------	------

Model	OCN-LH0.8	OCN-LH1.6	OCN-LH3.2	OCN-LH6.3	OCN-LH9.0
Capacity (lbs.)	1700	3500	7000	13800	19800

Dimensions (in.)	A	6.3	7.71	8.17	8.19	8.17
	B	3.94	4.29	4.8	4.8	4.8
	C	5.27	6.18	8.27	9.96	13.31
	D	1.57	1.77	2.17	2.68	3.35
	H-min	12.6	14.37	19.29	22.83	32.68
	L	9.84	10.63	16.93	16.93	16.93
	K	1.02	1.14	1.54	1.69	2.28

Net Weight (with 10' of chain)	15.65	23.81	51.37	78.48	92.37
Load Chain (mm)	6x18	8x24	10x30	10x30	10x30
Strands of Load Chain (#)	1	1	1	2	3
Strands Lift	Depends on selected chain length: No Chain, 5 ft. 10 ft., 15 ft., or 20 ft.				
Effort Required to Lift Rated Load (lbf.)	44.96	79.81	75.31	78.68	72.61

SKU by Chain Length	No Chain	OCN-LH0.8-NC	OCN-LH1.6-NC	OCN-LH3.2-NC	OCN-LH6.3-NC	OCN-LH9.0-NC
	5' Chain	OCN-LH0.8-05	OCN-LH1.6-05	OCN-LH3.2-05	OCN-LH6.3-05	OCN-LH9.0-05
	10' Chain	OCN-LH0.8-10	OCN-LH1.6-10	OCN-LH3.2-10	OCN-LH6.3-10	OCN-LH9.0-10
	15' Chain	OCN-LH0.8-15	OCN-LH1.6-15	OCN-LH3.2-15	OCN-LH6.3-15	OCN-LH9.0-15
	20' Chain	OCN-LH0.8-20	OCN-LH1.6-20	OCN-LH3.2-20	OCN-LH6.3-20	OCN-LH9.0-20

PARTS LIST & EXPLODED VIEW

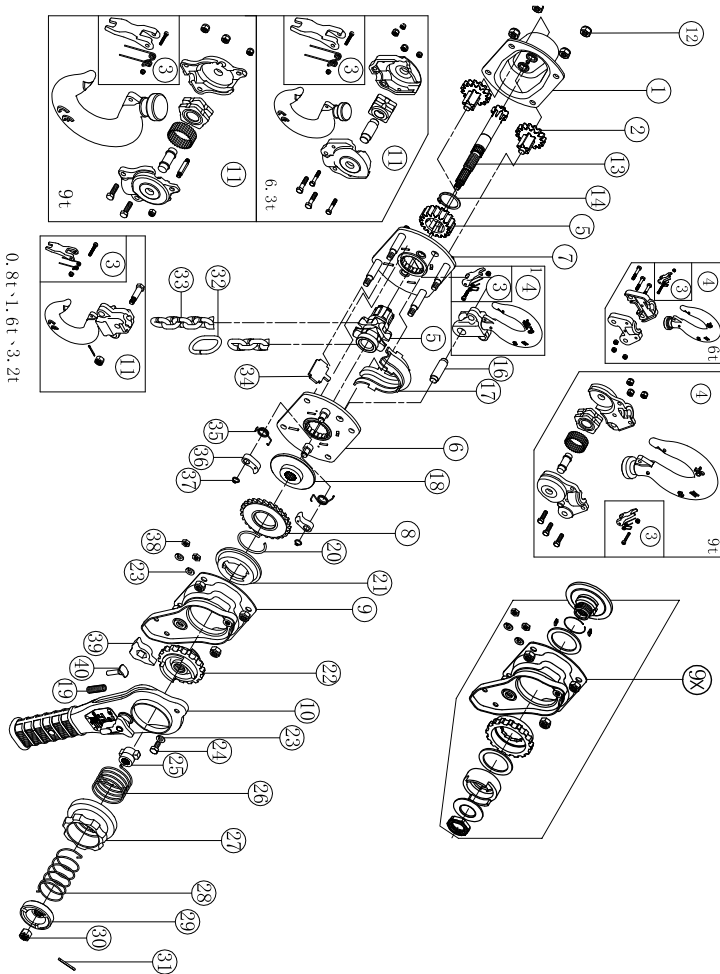

1	Gear case assembly	11	Bottom hook assy	21	Brake ring	31	Split pin
2	Disc gear assembly	12	Lock nut	22	Reversing ratchet wheel	32	End ring
3	Safety latch assembly	13	Drive shaft	23	Spring washer	33	Load chain
4	Top hook assembly	14	Snap ring	24	Hex bolt	34	Stripper
5	Load sheave	15	Splined gear	25	Adjusting cam	35	Pawl spring
6	Brake side plate assembly	16	Top hook shaft	26	Clutch spring	36	Pawl
7	Gear side plate assembly	17	Chain guide	27	Hand wheel	37	Snap ring
8	Ratchet disc assembly	18	Brake seat	28	Torsional spring	38	Hex nut
9	Brake cover	19	Spring	29	Torsional spring cover	39	Reversing pawl
10	Lever handle cover	20	Snap ring	30	Castle nut	40	Spring set

OCEAN[®] HOIST WARRANTY

WARRANTY COVERAGE

All Ocean[®] Hoist products are warranted to be free from defects in materials and workmanship for 2 years from the date of shipment.

All manual hoist products carry a 2 year warranty.

This warranty applies only when the product is used in accordance with manufacturer's recommendations and does not extend to products that have been:

- Overloaded, misused, or abused
- Altered or repaired by unauthorized personnel
- Improperly maintained
- Exposed to improper installation or adverse environmental conditions
- Subject to normal wear and tear of moving parts

WARRANTY CLAIM PROCEDURE

Visit www.oceanproducts.com/warranty-information to register your product or to initiate a warranty claim.

Notification: Buyer must notify Ocean[®] immediately upon discovery of an alleged defect.

Return Authorization: Obtain a Return Goods Authorization (RGA) from Ocean[®] prior to shipping any product.

Documentation: Include proof of purchase and a detailed description of the defect.

Shipping: Ship the product freight prepaid to an authorized Ocean[®] warranty depot.

Inspection: Ocean[®] will inspect the product to confirm whether a defect exists.

If a defect is confirmed, Ocean[®] will repair or replace the product at no additional cost to the Customer.

If no defect is found, or the defect is due to causes excluded in this warranty, Ocean[®] will return the item, unmodified, to the customer. Customer is responsible for prepayment of return shipping costs.

Post-Repair Coverage: Warranty coverage on repaired or replaced products continues for the remainder of the original warranty period.

Limitations of Liability

Ocean[®] shall not be liable for:

- Injury to persons or damage to property
- Incidental, consequential, or special damages
- Losses arising from misuse, negligence, or failure to follow installation/operating instructions

This warranty constitutes the only written warranty and replaces any other implied warranties, including merchantability or fitness for a particular purpose.