

# SWIVELS- Y-LINK, ANGULAR CONTACT BEARINGS



- First ever angular contact bearing design- developed 1<sup>st</sup> by Miller
- Standard models with Working Load Limits from 0.45 through 300 tons
- Specials available with Working Load Limits up to 1000 tons
- Wire rope sizes 1/8" and up
- Multiple Angular Contact Bearing Design extends the life of the wire rope, and maximizes efficiency, reliability and service life
- Lowest starting torque for faster response and higher rotational speeds
- Structural components machined from forged alloy steel- not cast
- Zinc plated inside and out for effective protection against corrosion
- Standard hook models utilize high quality forged alloy steel hooks produced to DIN standards 15400 and 15401
- Design Factor of 5 to 1 minimum for swivels 35 ton and below
- Design Factor of 4 to 1 minimum for swivels 45 tons and above

- Proof Load is 2 x WLL
- Models 8.5 tons and up include lubrication fitting
- See table of contents for stainless steel, high pressure, and other special models

GAP SPECIFICATIONS FOR Y-LINK SWIVELS					
MODEL	WLL (t)	ACCEPTABLE RANGE* (in)	MODEL	WLL (t)	ACCEPTABLE RANGE* (in)
A	0.45	.017/.029	HH	35	.030/.046
BB	0.75	.017/.031	I	45	.020/.050
B	1.5	.017/.031	J	50	.050/.092
C	3	.025/.041	JJ	60	.050/.092
D	5	.025/.041	K	75	.050/.092
EE	8.5	.025/.041	KK	100	.050/.092
G	10	.030/.047	KKK	150	.050/.092
GG	15	.030/.047	L	200	.068/.083
H	25	.030/.046	M	300	.068/.098

\* Gap between barrel and shank of swivel. If over limit take swivel out of service.  
 \* Swivel Gap to be measured under a maximum load of 1% of the WLL in a vertical position.

## SWIVELS- Y-LINK, ANGULAR CONTACT BEARINGS

### Y-LINK MODEL NUMBER SYSTEM

MODEL	CAPS					BARRELS					SHANKS					
	CLEVIS	EYE	STUD	BULLET NOSE	SOCKET	THIMBLE	WEDGE	HOOK	EYE BOLT	STANDARD BARREL	CLEVIS	EYE	STUD	BULLET NOSE	HOOK	EYE BOLT
W																
D																
L																
L																
A	1	2	3	4	5	6	7	8	9	1	2	3	4	5	6	
0.8	✓	✓	✓	✓						✓	✓	✓	✓	✓		
BB	✓	✓	✓	✓						✓	✓	✓	✓	✓		
1.5	✓	✓	✓	✓	✓	✓	✓	✓	✓	✓	✓	✓	✓	✓	✓	✓
B	✓	✓	✓	✓		✓				✓	✓	✓	✓	✓	✓	✓
C	✓	✓	✓	✓		✓				✓	✓	✓	✓	✓	✓	✓
3	✓	✓	✓	✓		✓				✓	✓	✓	✓	✓	✓	✓
5	✓	✓	✓	✓		✓				✓	✓	✓	✓	✓	✓	✓
D	✓	✓	✓	✓		✓				✓	✓	✓	✓	✓	✓	✓
8.5	✓	✓	✓	✓		✓				✓	✓	✓	✓	✓	✓	✓
EE	✓	✓	✓	✓		✓				✓	✓	✓	✓	✓	✓	✓
10	✓	✓	✓	✓		✓				✓	✓	✓	✓	✓	✓	✓
G	✓	✓	✓	✓		✓				✓	✓	✓	✓	✓	✓	✓
GG	✓	✓	✓	✓		✓				✓	✓	✓	✓	✓	✓	✓
15	✓	✓	✓	✓		✓				✓	✓	✓	✓	✓	✓	✓
H	✓	✓	✓	✓		✓				✓	✓	✓	✓	✓	✓	✓
25	✓	✓	✓	✓		✓				✓	✓	✓	✓	✓	✓	✓
HH	✓	✓	✓	✓		✓				✓	✓	✓	✓	✓	✓	✓
35	✓	✓	✓	✓		✓				✓	✓	✓	✓	✓	✓	✓
I	✓	✓	✓	✓		✓				✓	✓	✓	✓	✓	✓	✓
45	✓	✓	✓	✓		✓				✓	✓	✓	✓	✓	✓	✓
J	✓	✓	✓	✓		✓				✓	✓	✓	✓	✓	✓	✓
50	✓	✓	✓	✓		✓				✓	✓	✓	✓	✓	✓	✓
JJ	✓	✓	✓	✓		✓				✓	✓	✓	✓	✓	✓	✓
60	✓	✓	✓	✓		✓				✓	✓	✓	✓	✓	✓	✓
K	✓	✓	✓	✓		✓				✓	✓	✓	✓	✓	✓	✓
75	✓	✓	✓	✓		✓				✓	✓	✓	✓	✓	✓	✓
KK	✓	✓	✓	✓		✓				✓	✓	✓	✓	✓	✓	✓
100	✓	✓	✓	✓		✓				✓	✓	✓	✓	✓	✓	✓
KKK	✓	✓	✓	✓		✓				✓	✓	✓	✓	✓	✓	✓
150	✓	✓	✓	✓		✓				✓	✓	✓	✓	✓	✓	✓
L	✓	✓	✓	✓		✓				✓	✓	✓	✓	✓	✓	✓
200	✓	✓	✓	✓		✓				✓	✓	✓	✓	✓	✓	✓
M	✓	✓	✓	✓		✓				✓	✓	✓	✓	✓	✓	✓
300	✓	✓	✓	✓		✓				✓	✓	✓	✓	✓	✓	✓
MODEL	1	2	3	4	5	6	7	8	9	1	2	3	4	5	6	

NOTE:  CHECKED COMPONENTS ARE AVAILABLE AS STANDARD PRODUCTS. OTHERS MAY BE ADDED. FOR UNCHECKED, PLEASE CONTACT MILLER

MODEL NUMBER KEY:			
X	#	#	#
MODEL LETTER(S)	CAP NUMBER	BARREL NUMBER	SHANK NUMBER

EXAMPLE: D-115 = (D) 5 TON, (1) CLEVIS CAP, (1) STD. BARREL, (5) HOOK

# SWIVELS- Y-LINK, ANGULAR CONTACT BEARINGS

## CLEVIS TO CLEVIS - TYPE 111

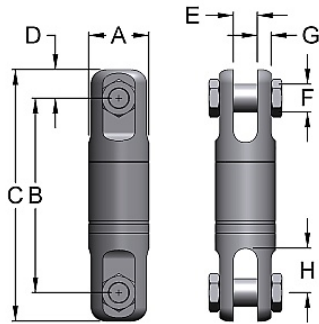

WLL* Tons	Model Number	Rope Size	A	B	C	D	E	F	G	H	Weight Lbs.
0.45	A-111	1/8	0.88	2.38	3.13	0.38	0.25	0.25	0.19	0.41	0.37
0.75	BB-111	1/4	1.31	3.5	4.38	0.44	0.31	0.38	0.22	0.56	0.93
1.5	B-111	3/8	1.63	4.06	5.44	0.69	0.5	0.5	0.31	0.78	2
3	C-111	1/2	2	6.25	8.09	0.94	0.75	0.75	0.38	1.19	4.5
5	D-111	5/8	2.5	7.94	10.09	1.13	1	0.88	0.56	1.56	9.5
8.5	EE-111	3/4	2.88	9.63	12.31	1.34	1.56	1.19	0.53	2.09	15.25
10	G-111	7/8	4	14	17.5	1.75	1.75	1.5	0.81	3.5	40
15	GG-111	1	4	14	17.5	1.75	1.75	1.5	0.81	3.5	40
25	H-111	1 1/4	5	15.94	20.69	2.38	2	2	1.13	3.69	78
35	HH-111	1 1/2	5	15.94	20.69	2.38	2	2	1.13	3.69	78
45	I-111		6	20.06	26.06	3	2.5	2.25	1.25	4	146
50	J-111		7	20.94	27.94	3.5	3	2.5	1.5	4.5	207
60	JJ-111		7	20.94	27.94	3.5	3	2.5	1.5	4.5	207
75	K-111		8	24	32	4	3.5	3	1.75	5	300
100	KK-111		10	32.88	43.88	5.5	4.06	4	2	6.75	692
150	KKK-111		10	32.88	43.88	5.5	4.06	4	2	6.75	692
200	L-111		11.5	36.52	48.02	5.75	5.06	4.5	2.56	7.75	985
300	M-111		14	43.95	58.95	7.5	6.13	4.75	3.94	9.5	1680

\* Design factors for WLL=35T and below are 5:1; for 45T and above 4:1

## CLEVIS TO EYE - TYPE 112

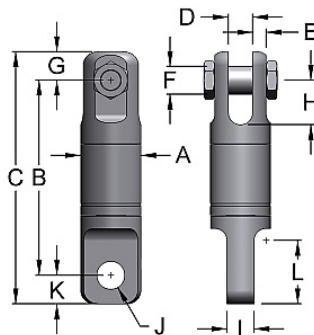

WLL* Tons	Model Number	Rope Size	A	B	C	D	E	F	G	H	I	J	K	L	Weight Lbs.
0.45	A-112	1/8	0.88	2.5	3.25	0.25	0.19	0.25	0.38	0.41	0.25	.26	0.38	0.75	0.31
0.75	BB-112	1/4	1.31	3.56	4.44	0.31	0.22	0.38	0.44	0.56	0.31	0.38	0.44	0.94	0.94
1.5	B-112	3/8	1.63	4.13	5.38	0.5	0.31	0.5	0.69	0.78	0.5	0.66	0.63	1.34	1.94
3	C-112	1/2	2	6.19	8.13	0.75	0.38	0.75	0.94	1.19	0.75	0.91	1	1.94	4.25
5	D-112	5/8	2.5	7.88	10.19	1	0.56	0.88	1.13	1.56	1	1.28	1.19	2.5	8.94
8.5	EE-112	3/4	2.88	9.5	12.34	1.56	0.53	1.19	1.34	2.19	1.25	1.41	1.5	3.13	15.25
10	G-112	7/8	4	13.94	17.5	1.75	0.81	1.5	1.75	3.5	1.72	1.66	1.81	4.66	39
15	GG-112	1	4	13.63	17.5	1.75	0.81	1.5	1.75	3.5	1.94	2.03	2.13	4.91	40
25	H-112	1 1/4	5	15.94	20.69	2	1.13	2	2.38	3.69	2.25	2.31	2.38	5.25	75
35	HH-112	1 1/2	5	15.94	20.69	2	1.13	2	2.38	3.69	2.25	2.31	2.38	5.25	75
45	I-112		6	20.06	26.06	2.5	1.25	2.25	3	4	2.5	2.53	3	7	139
50	J-112		7	20.94	27.94	3	1.5	2.5	3.5	4.5	2.94	2.88	3.5	7	205
60	JJ-112		7	20.94	27.94	3	1.5	2.5	3.5	4.5	2.94	2.88	3.5	7	205
75	K-112		8	24	32	3.5	1.75	3	4	5	3.5	3.38	4	8.13	305
100	KK-112		10	32.88	43.88	4.06	2	4	5.5	6.75	4.5	4.03	5.5	11.38	647
150	KKK-112		10	32.88	43.88	4.06	2	4	5.5	6.75	4.5	4.28	5.5	11.38	647
200	L-112		11.5	35.52	47.27	5.06	2.56	4.5	5.75	7.75	5	4.81	6	13	925
300	M-112		14	43.45	58.95	6.13	3.94	4.75	7.5	9.5	6	6.06	8	17	1645

\* Design factors for WLL=35T and below are 5:1; for 45T and above 4:1

## CLEVIS TO HOOK - TYPE 115

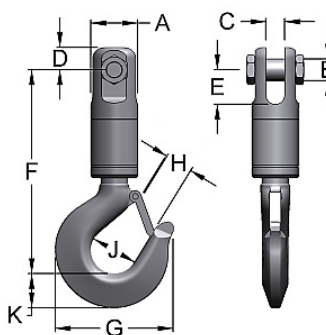

WLL* Tons	Model Number	Rope Size	A	B	C	D	E	F	G	H	J	K	Weight Lbs.
1.5	B-115	3/8	1.63	0.5	0.5	0.69	0.78	5.88	3.63	1	1.63	1	2.31
3	C-115	1/2	2	0.75	0.75	0.94	1.19	8.56	4.88	1.34	2	1.38	5.94
5	D-115	5/8	2.5	0.88	1	1.13	1.56	10.81	6.5	1.34	2.5	1.81	11.81
8.5	EE-115	3/4	2.88	1.19	1.56	1.34	2.09	13.75	8.69	2.25	3.25	2.59	24
10	G-115	7/8	4	1.5	1.75	1.75	3.5	17.88	11	3	3.25	3	53
15	GG-115	1	4	1.5	1.75	1.75	3.5	17.88	11	3	4.25	3	53
25	H-115	1 1/4	5	2	2	2.38	3.69	23.01	12.02	3.54	4.41	4.21	131
35	HH-115	1 1/2	5	2	2	2.38	3.69	23.01	12.02	3.54	4.41	4.21	131
45	I-115		6	2.25	2.5	3	4	27.65	13.46	3.94	4.92	4.69	211
50	J-115		7	2.5	3	3.5	4.5	29.34	15.12	4.41	5.51	5.26	293
60	JJ-115		7	2.5	3	3.5	4.5	29.34	15.12	4.41	5.51	5.26	293
75	K-115		8	3	3.5	4	5	33.36	17	4.92	6.3	5.97	411
100	KK-115		10	4	4.06	5.5	6.75	45.31	21.34	6.3	7.87	7.55	922
150	KKK-115		10	4	4.06	5.5	6.75	46.98	24	7.09	8.82	8.42	1095
200	L-115		11.5	4.5	5.06	5.75	7.75	50.48	26.95	7.87	9.84	9.29	1510
300	M-115		14	4.75	6.13	7.5	9.5	63.13	33.69	9.17	12.4	11.81	2800

\* Design factors for WLL=35T and below are 5:1; for 45T and above 4:1

## SWIVELS- Y-LINK, ANGULAR CONTACT BEARINGS

### CLEVIS TO EYE BOLT - TYPE 116

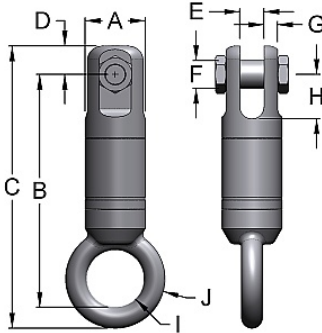

WLL* Tons	Model Number	Rope Size	A	B	C	D	E	F	G	H	I	J	Weight Lbs.
1.5	B-116	3/8	1.63	5.44	6.75	0.69	0.5	0.5	0.31	0.78	1.5	2.75	2.19
3	C-116	1/2	2	7.47	9.16	0.94	0.75	0.75	0.38	1.19	1.75	3.5	4.5
5	D-116	5/8	2.5	9.31	11.44	1.13	1	0.88	0.56	1.56	2	4	9.56
8.5	EE-116	3/4	2.88	11.09	13.44	1.34	1.56	1.19	0.53	2.09	2.5	4.5	14.75
10	G-116	7/8	4	15.91	19.47	1.75	1.75	1.5	0.81	3.5	3.25	6.88	43
15	GG-116	1	4	15.91	19.47	1.75	1.75	1.5	0.81	3.5	3.25	6.88	43

\* Design factors for WLL=35T and below are 5:1; for 45T and above 4:1

### EYE TO CLEVIS - TYPE 211

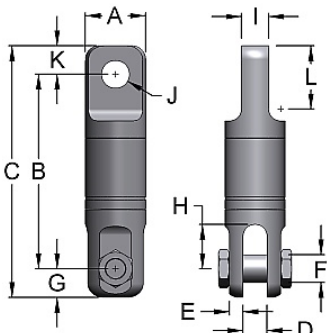

WLL* Tons	Model Number	Rope Size	A	B	C	D	E	F	G	H	I	J	K	L	Weight Lbs.
0.45	A-211	1/8	0.88	2.5	3.25	0.25	0.19	0.25	0.38	0.41	0.25	.26	0.38	0.75	0.38
0.75	BB-211	1/4	1.31	3.63	4.5	0.31	0.22	0.38	0.44	0.44	0.31	.39	0.44	0.94	0.94
1.5	B-211	3/8	1.63	4.13	5.44	0.5	0.31	0.5	0.69	0.78	0.5	0.66	0.63	1.34	1.88
3	C-211	1/2	2	6.19	8.13	0.75	0.38	0.75	0.94	1.19	0.75	0.91	1	1.94	4.31
5	D-211	5/8	2.5	7.88	10.19	1	0.56	0.88	1.13	1.56	1	1.28	1.19	2.5	9.06
8.5	EE-211	3/4	2.88	9.5	12.34	1.56	0.53	1.19	1.34	2.19	1.25	1.41	1.5	3.13	14.75
10	G-211	7/8	4	13.94	17.5	1.75	0.81	1.5	1.75	3.5	1.72	1.66	1.81	4.66	39
15	GG-211	1	4	13.63	17.5	1.75	0.81	1.5	1.75	3.5	1.94	2.03	2.13	4.91	40
25	H-211	1 1/4	5	15.94	20.69	2	1.13	2	2.38	3.69	2.25	2.31	2.38	5.25	75
35	HH-211	1 1/2	5	15.94	20.69	2	1.13	2	2.38	3.69	2.25	2.31	2.38	5.25	75
45	I-211		6	20.06	26.06	2.5	1.25	2.25	3	4	2.5	2.53	3	7	139
50	J-211		7	20.94	27.94	3	1.5	2.5	3.5	4.5	2.94	2.88	3.5	7	211
60	JJ-211		7	20.94	27.94	3	1.5	2.5	3.5	4.5	2.94	2.88	3.5	7	211
75	K-211		8	24	32	3.5	1.75	3	4	5	3.5	3.38	4	8.13	305
100	KK-211		10	32.88	43.88	4.06	2	4	5.5	6.75	4.5	4.03	5.5	11.38	678
150	KKK-211		10	32.88	43.88	4.06	2	4	5.5	6.75	4.5	4.28	5.5	11.38	678
200	L-211		11.5	36.67	48.42	5.06	2.56	4.5	5.75	7.75	5	4.81	6	13	960
300	M-211		14	43.45	58.95	6.13	3.94	4.75	7.5	9.5	6	6.06	8	17	1645

\* Design factors for WLL=35T and below are 5:1; for 45T and above 4:1

### EYE TO EYE - TYPE 212

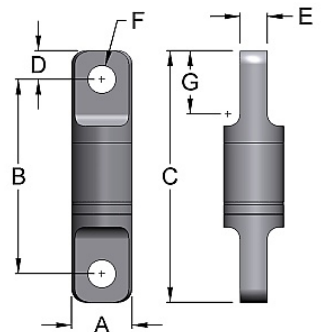

WLL* Tons	Model Number	Rope Size	A	B	C	D	E	F	G	Weight Lbs.
0.45	A-212	1/8	0.88	2.63	3.38	0.38	0.25	.26	0.75	0.31
0.75	BB-212	1/4	1.31	3.81	4.69	0.44	0.31	.39	0.94	0.93
1.5	B-212	3/8	1.63	4.13	5.38	0.63	0.5	0.66	1.34	1.87
3	C-212	1/2	2	6.13	8.13	1	0.75	0.91	1.94	4.06
5	D-212	5/8	2.5	7.81	10.19	1.19	1	1.28	2.5	8.5
8.5	EE-212	3/4	2.88	9.31	12.31	1.5	1.25	1.41	3.13	14.75
10	G-212	7/8	4	13.88	17.5	1.81	1.72	1.66	4.66	37
15	GG-212	1	4	13.25	17.5	2.13	1.94	2.03	4.91	39
25	H-212	1 1/4	5	15.94	20.69	2.38	2.25	2.31	5.25	72
35	HH-212	1 1/2	5	15.94	20.69	2.38	2.25	2.31	5.25	72
45	I-212		6	20.06	26.06	3	2.5	2.53	7	132
50	J-212		7	20.94	27.94	3.5	2.94	2.88	7	209
60	JJ-212		7	20.94	27.94	3.5	2.94	2.88	7	209
75	K-212		8	24	32	4	3.5	3.38	8.13	311
100	KK-212		10	32.88	43.88	5.5	4.5	4.03	11.38	653
150	KKK-212		10	32.88	43.88	5.5	4.5	4.28	11.38	657
200	L-212		11.5	35.67	47.67	6	5	4.81	13	900
300	M-212		14	42.95	58.95	8	6	6.06	17	1610

\* Design factors for WLL=35T and below are 5:1; for 45T and above 4:1

# SWIVELS- Y-LINK, ANGULAR CONTACT BEARINGS

## EYE TO HOOK - TYPE 215

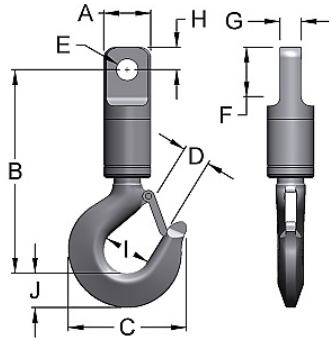

WLL* Tons	Model Number	Rope Size	A	B	C	D	E	F	G	H	I	J	Weight Lbs.
1.5	B-215	3/8	1.63	6.19	3.63	1	0.66	1.34	0.5	0.63	1.63	1	2.25
3	C-215	1/2	2	8.56	4.88	1.34	0.91	1.94	0.75	1	2	1.38	5.81
5	D-215	5/8	2.5	10.88	6.5	1.69	1.28	2.5	1	1.19	2.5	1.81	11.37
8.5	EE-215	3/4	2.88	13.63	8.69	2.25	1.41	3.13	1.25	1.5	3.25	2.59	23.5
10	G-215	7/8	4	17.81	11	3	1.66	4.66	1.72	1.81	3.25	3	52
15	GG-215	1	4	17.56	11	3	2.03	4.91	1.94	2.13	4.25	3	53
25	H-215	1 1/4	5	23.01	12.02	3.54	2.31	5.25	2.25	2.38	4.41	4.21	128
35	HH-215	1 1/2	5	23.01	12.02	3.54	2.31	5.25	2.25	2.38	4.41	4.21	128
45	I-215		6	27.65	13.46	3.94	2.53	7	2.5	3	4.92	4.69	205
50	J-215		7	29.34	15.12	4.41	2.88	7	2.94	3.5	5.51	5.26	289
60	JJ-215		7	29.34	15.12	4.41	2.88	7	2.94	3.5	5.51	5.26	289
75	K-215		8	33.36	17	4.92	3.38	8.13	3.5	4	6.3	5.97	423
100	KK-215		10	45.31	21.34	6.3	4.03	11.38	4.5	5.5	7.87	7.55	913
150	KKK-215		10	46.98	24	7.09	4.28	11.38	4.5	5.5	8.82	8.42	1087
200	L-215		11.5	50.82	26.95	7.87	4.81	13	5	6	9.84	9.29	1485
300	M-215		14	63.13	33.69	9.17	6.06	17	6	8	12.4	8.63	2835

\* Design factors for WLL=35T and below are 5:1; for 45T and above 4:1

## STUD TO CLEVIS - TYPE 311

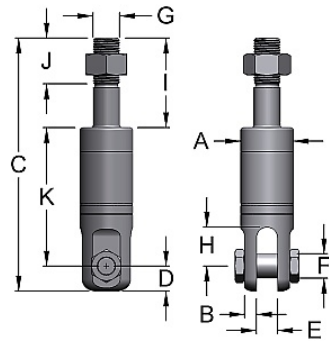

WLL* Tons	Model Number	Rope Size	A	B	C	D	E	F	G	H	I	J	K	Weight Lbs.
0.45	A-311	1/8	0.88	0.19	4.06	0.38	0.25	0.25	0.38	0.41	1.5	1.19	2.19	0.37
0.75	BB-311	1/4	1.31	0.22	5.63	0.44	0.31	0.38	0.63	0.56	2	1.5	3.19	1.06
1.5	B-311	3/8	1.63	0.31	6.06	0.69	0.5	0.5	0.75	0.78	2	1.5	3.75	1.87
3	C-311	1/2	2	0.38	9.19	0.94	0.75	0.75	0.88	1.19	3	2.63	5.25	4.5
5	D-311	5/8	2.5	0.56	11.19	1.13	1	0.88	1.25	1.56	3.5	3.13	6.56	9.75
8.5	EE-311	3/4	2.88	0.53	13.03	1.56	1.56	1.19	1.5	2.19	4	3	7.69	14.5
10	G-311	7/8	4	0.81	17.44	1.75	1.75	1.5	2	3.5	5.5	3	10.19	37
15	GG-311	1	4	0.81	17.44	1.75	1.75	1.5	2	3.5	5.5	3	10.19	37
25	H-311	1 1/4	5	1.13	23.31	2.38	2	2	2.5	3.69	8.5	4.25	12.44	78
35	HH-311	1 1/2	5	1.13	23.31	2.38	2	2	2.5	3.69	8.5	4.25	10.44	78
45	I-311		6	1.25	25.56	3	2.5	2.25	3	4	8	4	14.56	131
50	J-311		7	1.5	28.44	3.5	3	2.5	3.25	4.5	8	4	16.94	198
60	JJ-311		7	1.5	28.44	3.5	3	2.5	3.25	4.5	8	4	16.94	198
75	K-311		8	1.75	33.5	4	3.5	3	3.75	5	10	5	19.5	271
100	KK-311		10	2	51.13	5.5	4.06	4	6.25	6.75	20.5	7.25	25.13	648

\* Design factors for WLL=35T and below are 5:1; for 45T and above 4:1

## STUD TO HOOK - TYPE 315

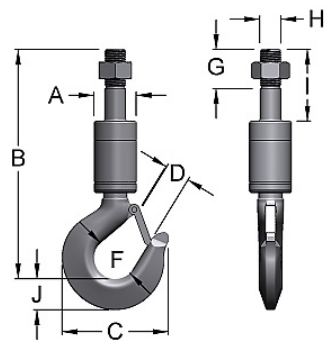

WLL* Tons	Model Number	Rope Size	A	B	C	D	F	G	H	I	J	Weight Lbs.
1.5	B-315	3/8	1.63	7.25	3.63	1	1.63	1.5	0.75	2	1	2.25
3	C-315	1/2	2	10.63	4.88	1.34	2	2.63	0.88	3	1.38	6
5	D-315	5/8	2.5	13	6.5	1.69	2.5	3.13	1.25	3.5	1.81	12.06
8.5	EE-315	3/4	2.88	15.81	8.69	2.25	3.25	3	1.5	4	2.59	23.25
10	G-315	7/8	4	19.59	11	3	3.25	3	2	5.5	3	50
15	GG-315	1	4	19.59	11	3	4.25	3	2	5.5	3	50
25	H-315	1 1/4	5	28.5	12.02	3.54	4.41	4.25	2.5	8.5	4.21	133
35	HH-315	1 1/2	5	28.5	12.02	3.54	4.41	4.25	2.5	8.5	4.21	133
45	I-315		6	30.13	13.46	3.94	4.92	4	3	8	4.69	188
50	J-315		7	33.34	15.12	4.41	5.51	4	3.25	8	5.26	278
60	JJ-315		7	33.34	15.12	4.41	5.51	4	3.25	8	5.26	278
75	K-315		8	38.82	17	4.92	6.3	5	3.75	10	5.97	403
100	KK-315		10	58.2	21.34	6.3	7.87	7.25	6.5	20.5	7.55	941

\* Design factors for WLL=35T and below are 5:1; for 45T and above 4:1

## SWIVELS- Y-LINK, ANGULAR CONTACT BEARINGS

### BULLET NOSE TO BULLET NOSE - TYPE 414

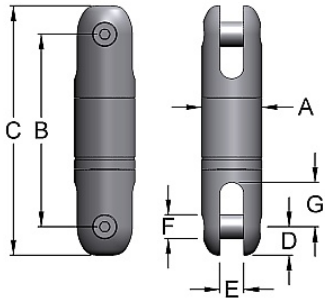

WLL* Tons	Model Number	Rope Size	A	B	C	D	E	F	G	Weight Lbs.
0.45	A-414	1/8	0.88	2.38	3.13	0.38	0.25	0.31	0.41	0.37
0.75	BB-414	1/4	1.31	3.56	4.44	0.44	0.31	0.38	0.56	1.12
1.5	B-414	3/8	1.63	4.06	5.19	0.56	0.5	0.44	0.81	1.81
3	C-414	1/2	2	5.44	7.06	0.81	0.75	0.63	0.94	3.87
5	D-414	5/8	2.5	7.88	10.19	1.13	1	0.88	1.56	8.06
8.5	EE-414	3/4	2.88	9.81	12.31	1.25	1.28	1	2.13	14.5
10	G-414	7/8	4	13.25	16.75	1.75	1.75	1.5	3.25	40
15	GG-414	1	4	13.25	16.75	1.75	1.75	1.5	3.25	40
25	H-414	1 1/4	5	15.91	20.66	2.38	2	2	3.69	84
35	HH-414	1 1/2	5	15.91	20.66	2.38	2	2	3.69	84
45	I-414		6	20.08	26.08	3	2.5	2.25	4	134

\* Design factors for WLL=35T and below are 5:1; for 45T and above 4:1

### SOCKET TO CLEVIS - TYPE 511

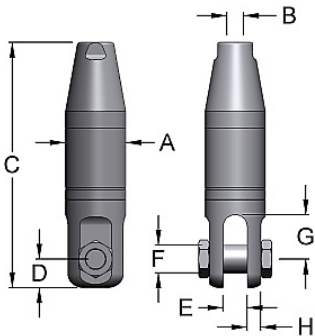

WLL* Tons	Model Number	Rope Size	A	B	C	D	E	F	G	H	Weight Lbs.
1.5	B-511	3/8	1.63	0.44	6.19	0.69	0.5	0.5	0.78	0.31	1.87
3	C-511	1/2	2	0.56	8.94	0.94	0.75	0.75	1.19	0.38	4.43
5	D-511	5/8	2.5	0.69	10.44	1.13	1	0.88	1.56	0.56	8.68
8.5	EE-511	3/4	2.88	0.81	12.75	1.34	1.56	1.19	2.09	0.53	14.5
10	G-511	7/8	4	0.97	16.25	1.75	1.75	1.5	3.5	0.81	33
15	GG-511	1	4	1.13	16.25	1.75	1.75	1.5	3.5	0.81	33
25	H-511	1 1/4	5	1.38	20.19	2.38	2	2	3.69	1.13	74
35	HH-511	1 1/2	5	1.63	20.19	2.38	2	2	3.69	1.13	74

\* Design factors for WLL=35T and below are 5:1; for 45T and above 4:1

### SOCKET TO EYE - TYPE 512

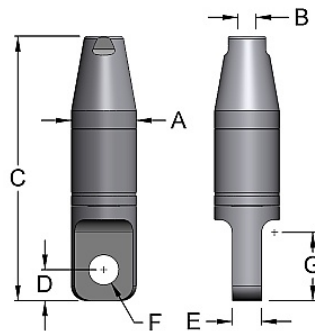

WLL* Tons	Model Number	Rope Size	A	B	C	D	E	F	Weight Lbs.
1.5	B-512	3/8	1.63	0.44	6.19	0.63	0.5	0.66	1.87
3	C-512	1/2	2	0.56	8.94	1	0.75	0.91	4.43
5	D-512	5/8	2.5	0.69	10.44	1.19	1	1.28	8.68
8.5	EE-512	3/4	2.88	0.81	12.75	1.5	1.25	1.41	14.5
10	G-512	7/8	4	0.97	16.25	1.81	1.72	1.66	33
15	GG-512	1	4	1.13	16.25	2.13	1.94	2.03	33
25	H-512	1 1/4	5	1.38	20.19	2.38	2.25	2.31	74
35	HH-512	1 1/2	5	1.63	20.19	2.38	2.25	2.31	74

\* Design factors for WLL=35T and below are 5:1; for 45T and above 4:1

### SOCKET TO HOOK - TYPE 515

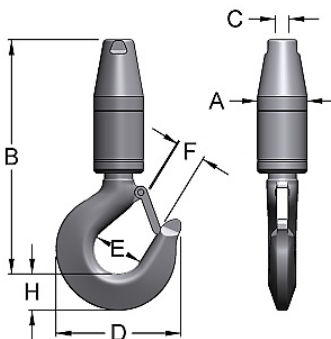

WLL* Tons	Model Number	Rope Size	A	B	C	D	E	F	H	Weight Lbs.
1.5	B-515	3/8	1.63	7.38	0.44	3.63	1.63	1	1	2.18
3	C-515	1/2	2	10.38	0.56	4.88	2	1.34	1.38	5.87
5	D-515	5/8	2.5	12.19	0.69	6.5	2.5	1.69	1.81	11
8.5	EE-515	3/4	2.88	15.56	0.81	8.69	3.25	2.25	2.59	23.25
10	G-515	7/8	4	18.38	0.97	11	3.25	3	3	46
15	GG-515	1	4	18.38	1.13	11	4.25	3	3	46
25	H-515	1 1/4	5	24.88	1.38	12.02	4.41	3.54	4.21	125
35	HH-515	1 1/2	5	24.88	1.63	12.02	4.41	3.54	4.21	125

\* Design factors for WLL=35T and below are 5:1; for 45T and above 4:1

# SWIVELS- Y-LINK, ANGULAR CONTACT BEARINGS

## THIMBLE TO CLEVIS - TYPE 611

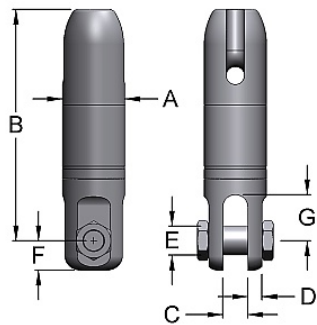

WLL* Tons	Model Number	Rope Size	A	B	C	D	E	F	G	Weight Lbs.
1.5	B-611	3/8	1.63	6	0.5	0.31	0.5	0.69	0.78	2.5
3	C-611	1/2	2	8.06	0.75	0.38	0.75	0.94	1.19	5.25
5	D-611	5/8	2.5	9.31	1	0.56	0.88	1.13	1.56	10
8.5	EE-611	3/4	2.88	11.38	1.56	0.53	1.19	1.34	2.09	16.5
10	G-611	7/8	4	15.38	1.75	0.81	1.5	1.75	3.5	42
15	GG-611	1	4	15.38	1.75	0.81	1.5	1.75	3.5	42
25	H-611	1 1/4	5	18.31	2	1.13	2	2.38	2.69	80
35	HH-611	1 1/2	5	18.31	2	1.13	2	2.38	2.69	80

\* Design factors for WLL=35T and below are 5:1; for 45T and above 4:1

## THIMBLE TO EYE - TYPE 612

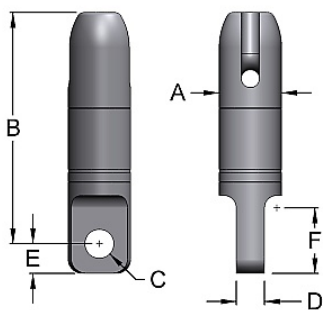

WLL* Tons	Model Number	Rope Size	A	B	C	D	E	F	Weight Lbs.
1.5	B-612	3/8	1.63	6.13	0.66	0.5	0.63	1.34	2.43
3	C-612	1/2	2	8	0.91	0.75	1	1.94	6
5	D-612	5/8	2.5	9.25	1.28	1	1.19	2.5	9.43
8.5	EE-612	3/4	2.88	11.31	1.41	1.25	1.5	3.13	16.5
10	G-612	7/8	4	15.44	1.66	1.72	1.81	4.66	41
15	GG-612	1	4	15.44	2.03	1.94	2.13	4.91	42
25	H-612	1 1/4	5	18.31	2.31	2.25	2.38	5.25	75
35	HH-612	1 1/2	5	18.31	2.31	2.25	2.38	5.25	75

\* Design factors for WLL=35T and below are 5:1; for 45T and above 4:1

## THIMBLE TO BULLET NOSE - TYPE 614

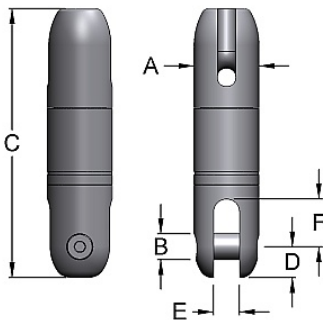

WLL* Tons	Model Number	Rope Size	A	B	C	D	E	F	Weight Lbs.
1.5	B-614	3/8	1.63	0.44	6.61	1	0.5	1.5	2
3	C-614	1/2	2	0.63	8.55	1.34	0.75	2.63	6.06
5	D-614	5/8	2.5	0.88	10.44	1.69	1	3.13	9.5
8.5	EE-614	3/4	2.88	1	12.77	1.25	1.28	2.13	16.5
10	G-614	7/8	4	1.5	17.25	3	1.75	3	38.5
15	GG-614	1	4	1.5	17.25	3	1.75	3	38.5
25	H-614	1 1/4	5	2	20.69	3.63	2	4.25	76
35	HH-614	1 1/2	5	2	20.69	3.75	2	4.25	76

\* Design factors for WLL=35T and below are 5:1; for 45T and above 4:1

## THIMBLE TO HOOK - TYPE 615

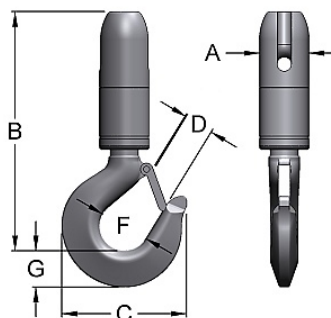

WLL* Tons	Model Number	Rope Size	A	B	C	D	F	G	Weight Lbs.
1.5	B-615	3/8	1.63	7.81	3.63	1	1.63	1	2.87
3	C-615	1/2	2	10.44	4.88	1.34	2	1.38	6.81
5	D-615	5/8	2.5	12.19	6.5	1.69	2.5	1.81	12.31
8.5	EE-615	3/4	2.88	15.56	8.69	2.25	3	2.59	25.25
10	G-615	7/8	4	19.38	11	3	3.25	3	55
15	GG-615	1	4	19.38	11	3	4.25	3	55
25	H-615	1 1/4	5	25.38	12.02	3.54	4.41	4.21	136
35	HH-615	1 1/2	5	25.38	12.02	3.54	4.41	4.21	136

\* Design factors for WLL=35T and below are 5:1; for 45T and above 4:1

## SWIVELS- Y-LINK, ANGULAR CONTACT BEARINGS

### WEDGE TO CLEVIS - TYPE 711

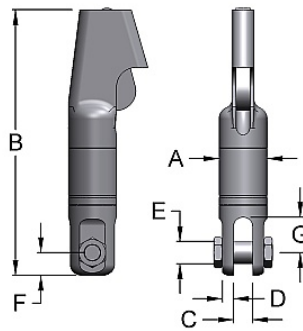

WLL* Tons	Model Number	Rope Size	A	B	C	D	E	F	G	Weight Lbs.
3	C-711	1/2	2	10.25	0.75	0.38	0.75	0.94	1.19	6.31
5	D-711	1/2, 5/8	2.5	12.53	1	0.56	0.88	1.13	1.56	12.56
8.5	EE-711	1/2, 5/8, 3/4	2.88	14.44	1.56	0.53	1.19	1.34	2.09	20.5
10	G-711	3/4, 7/8, 1	4	19.75	1.75	0.81	1.5	1.75	3.5	47
15	GG-711	3/4, 7/8, 1	4	19.75	1.75	0.81	1.5	1.75	3.5	47
25	H-711	1 1/8, 1 1/4	5	27.31	2	1.13	2	2.38	3.69	98
35	HH-711	1 1/8, 1 1/4	5	27.31	2	1.13	2	2.38	3.69	98

\* Design factors for WLL=35T and below are 5:1; for 45T and above 4:1

### WEDGE TO EYE - TYPE 712

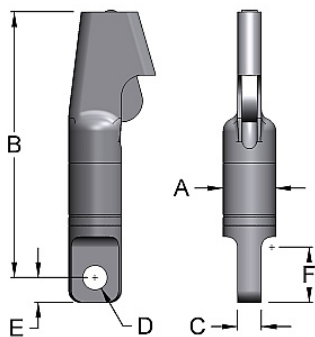

WLL* Tons	Model Number	Rope Size	A	B	C	D	E	F	Weight Lbs.
3	C-712	1/2	2	10.25	0.75	0.91	1	1.94	6.06
5	D-712	1/2, 5/8	2.5	12.5	1	1.28	1.19	2.5	12
8.5	EE-712	1/2, 5/8, 3/4	2.88	14.25	1.25	1.41	1.5	3.13	20.5
10	G-712	3/4, 7/8, 1	4	19.69	1.72	1.66	1.81	4.66	45
15	GG-712	3/4, 7/8, 1	4	19.38	1.94	2.03	2.13	4.91	46
25	H-712	1 1/8, 1 1/4	5	25.43	2.25	2.31	2.38	5.25	94
35	HH-712	1 1/8, 1 1/4	5	25.43	2.25	2.31	2.38	5.25	94

\* Design factors for WLL=35T and below are 5:1; for 45T and above 4:1

### WEDGE TO BULLET NOSE - TYPE 714

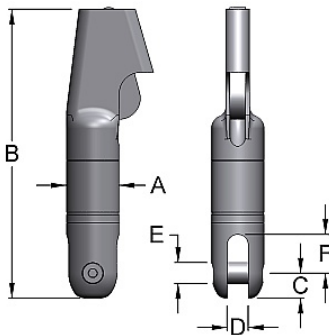

WLL* Tons	Model Number	Rope Size	A	B	C	D	E	F	Weight Lbs.
3	C-714	1/2	2	9.92	0.81	0.75	0.63	0.94	3.87
5	D-714	1/2, 5/8	2.5	12.42	1.13	1	0.88	1.56	8.06
8.5	EE-714	1/2, 5/8, 3/4	2.88	14.47	1.25	1.28	1	2.13	14.5
10	G-714	3/4, 7/8, 1	4	19.75	1.75	1.75	1.5	3.25	40
15	GG-714	3/4, 7/8, 1	4	19.75	1.75	1.75	1.5	3.25	40
25	H-714	1 1/8, 1 1/4	5	27.3	2.38	2	2	3.69	96
35	HH-714	1 1/8, 1 1/4	5	27.3	2.38	2	2	3.69	96

\* Design factors for WLL=35T and below are 5:1; for 45T and above 4:1

### WEDGE TO HOOK - TYPE 715

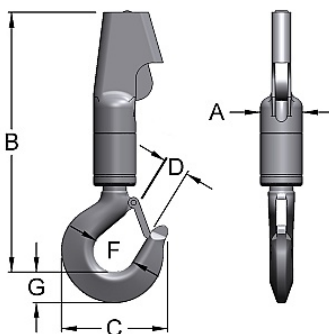

WLL* Tons	Model Number	Rope Size	A	B	C	D	F	G	Weight Lbs.
3	C-715	1/2	2	12.63	4.88	1.34	2	1.38	7.81
5	D-715	1/2, 5/8	2.5	15.44	6.5	1.81	2.5	1.81	14.87
8.5	EE-715	1/2, 5/8, 3/4	2.88	18.56	8.81	2.25	3.25	2.59	29.25
10	G-715	3/4, 7/8, 1	4	23.63	11	3	3.25	3	60
15	GG-715	3/4, 7/8, 1	4	23.63	11	3	4.25	3	60
25	H-715	1 1/8, 1 1/4	5	32	12.02	3.54	4.41	4.21	145
35	HH-715	1 1/8, 1 1/4	5	32	12.02	3.54	4.41	4.21	145

\* Design factors for WLL=35T and below are 5:1; for 45T and above 4:1