

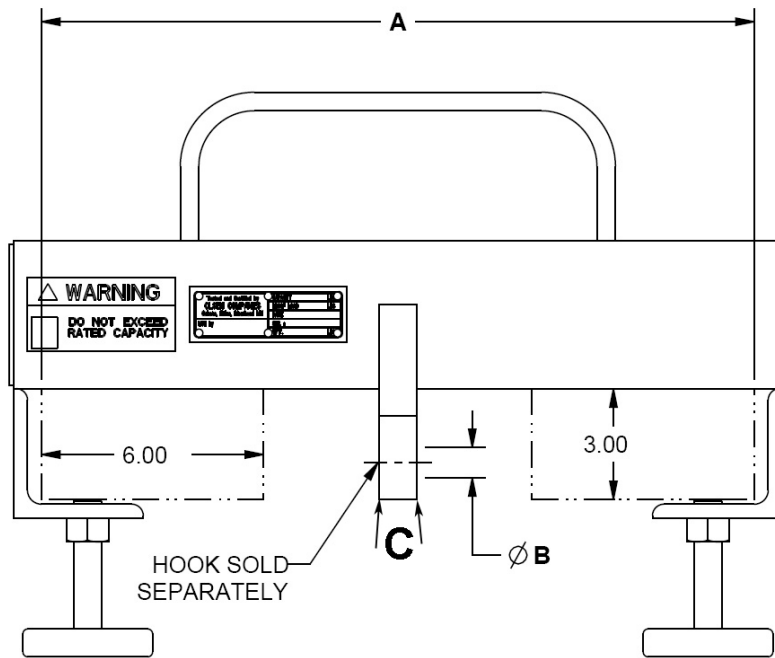

Forklift Attachments Forklift Lifting Beams Inside Shackle Mount

Forklift Lifting Beams - Inside Shackle Mount

- Manufactured to exceed all ASME B30.20 and OSHA regulations.
- Painted safety yellow for increased visibility.
- **ALL** forklift attachments proof loaded and shipped with certification paperwork.
- Durable construction ideally suited to jobsite or warehouse use.
- Carrying handle for easy placement by personnel - **HANDLE NOT INTENDED FOR LIFTING LOADS.**
- Check with manufacturer of your forklift for load capabilities.
- Made in U.S.A.
- Machined to exacting tolerances.
- Custom lettering available - call for details.
- Custom designs available - call for engineering.
- **ALL** lifting equipment individually proof loaded per OSHA requirements.
- Includes forklift restraining tabs.



RFID TRACKING



CHIP EQUIPPED

Working Load Limit in Pounds*	Part Number	A	B	C	Weight
5,000	11619	19.25	0.810	1.00	30
10,000	11620	23.25	1.130	1.25	50

* Call for specifications on larger sizes and capacities

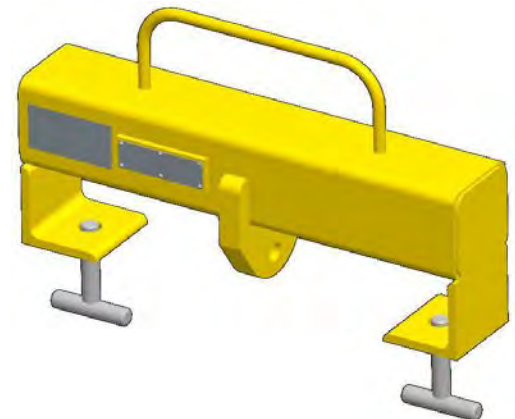

Distributed By

WESTECH RIGGING SUPPLY

Visit Us Online at: www.WestechRigging.com

Call Us Toll Free at: 800-442-7475

Call Us or Visit Our Stores: Monday - Friday, 8:00am - 5:30pm Pacific

4140 West 11th Avenue
Eugene, Oregon 97402

2439 McGilchrist St SE
Salem, Oregon 97302



Forklift Attachments
Forklift Lifting Beams Outside Hooks



Forklift Lifting Beams - Outside Hooks

- Manufactured to exceed all ASME B30.20 and OSHA regulations.
- Painted safety yellow for increased visibility.
- **ALL** forklift attachments proof loaded and shipped with certification paperwork.
- Durable construction ideally suited to jobsite or warehouse use.
- Check with manufacturer of your forklift for load capabilities.
- Made in U.S.A.
- Machined to exacting tolerances.
- Custom lettering available - call for details.
- Custom designs available - call for engineering.
- Includes forklift restraining tabs.
- Carrying handle for easy placement by personnel - **HANDLE NOT INTENDED FOR LIFTING LOADS.**

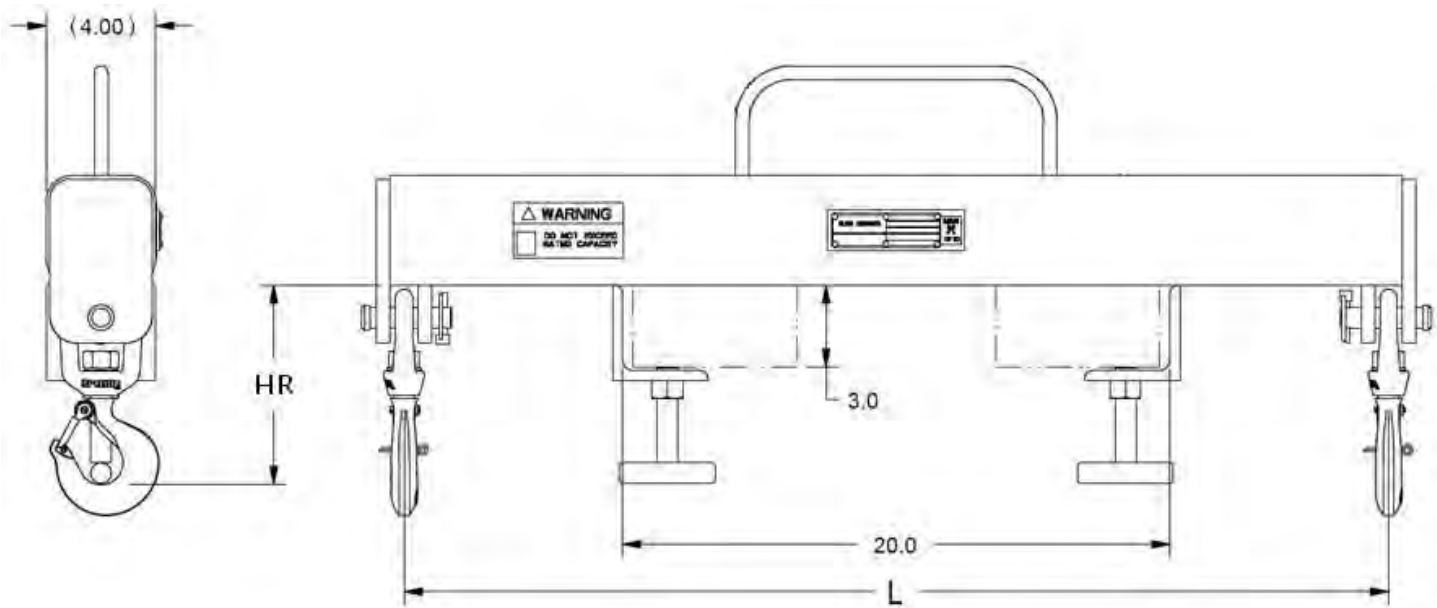

Working Load Limit in Pounds*	Part Number	HR	L	Weight
5,000	12343	6.2	36	49
10,000	12363	7.3	36	76
14,000	16523	8.8	36	90
22,000	16524	11.0	36	125

* Call for specifications on larger sizes and capacities

RFID TRACKING



CHIP EQUIPPED

FORKLIFT ATTACHMENTS

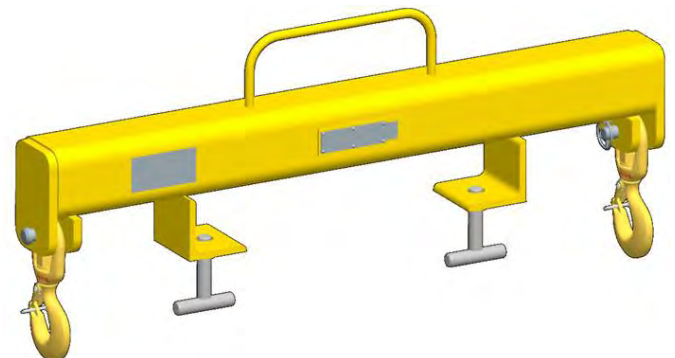



Forklift Attachments Forklift Lifting Beam Inside Pin Mount

Forklift Lifting Beam - Inside Pin Mount

- Manufactured to exceed all ASME B30.20 and OSHA regulations.
- Painted safety yellow for increased visibility.
- **ALL** forklift attachments proof loaded and shipped with certification paperwork.
- Durable construction ideally suited to jobsite or warehouse use.
- Carrying handles for easy placement by personnel - **HANDLE NOT INTENDED FOR LIFTING LOADS.**
- Check with manufacturer of your forklift for load capabilities.
- Made in U.S.A.
- Machined to exacting tolerances.
- Custom lettering available - call for details.
- Custom designs available - call for engineering.
- **ALL** lifting equipment individually proof loaded per OSHA requirements.
- **HOOK NOT INCLUDED.**
- Swivel Hook with bearing available for applications where the load needs to swivel while suspended.
- Includes forklift restraining tabs.

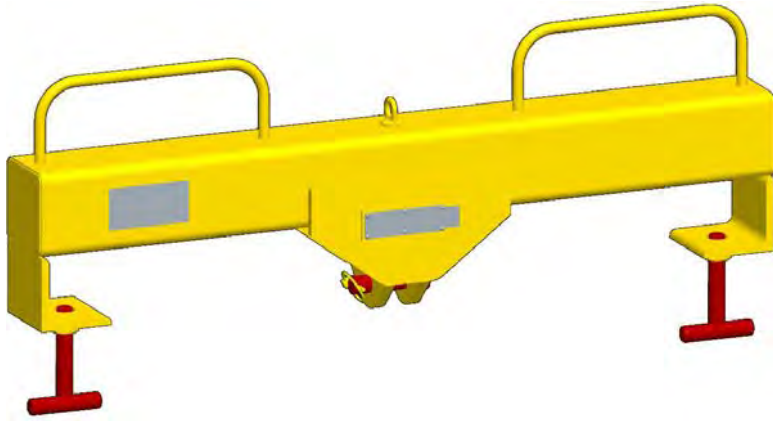

RFID TRACKING



CHIP EQUIPPED

Working Load Limit in Pounds*	Part Number	Weight in Pounds	A	B	Swivel Hook part number	Swivel Hook with bearing part number	Replacement latch part number	Replacement T-Handle part number	Replacement pin part number
5,000	16337	56	36	0.88	1048831	1028614	1096468	11599	16340
10,000	16336	75	36	1.00	1048837	1028623	1096515	11599	16341
15,000	17000	135	48	1.13	1048865	1028641	1096609	11599	14158
20,000	16338	156	36	1.25	1048865	1028641	1096609	11599	16242

* Call for specifications on larger sizes and capacities

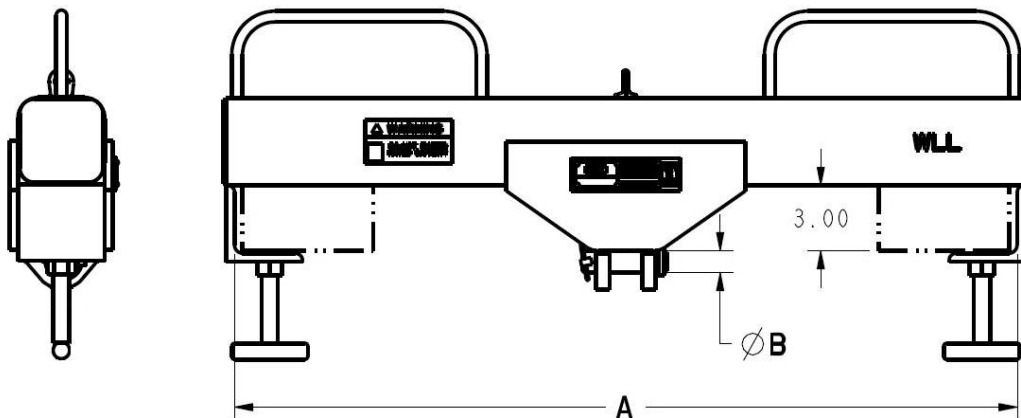

Forklift Lifting Beams - Adjustable Reach Over Boom

- Manufactured to exceed all ASME B30.20 and OSHA regulations.
- Painted safety yellow for increased visibility.
- **ALL** forklift attachments proof loaded and shipped with certification paperwork.
- Durable construction ideally suited to jobsite or warehouse use.
- Check with manufacturer of your forklift for load capabilities.

- Made in U.S.A.
- Machined to exacting tolerances.
- Custom lettering available - call for details.
- Custom designs available - call for engineering.
- Includes forklift restraining tabs.

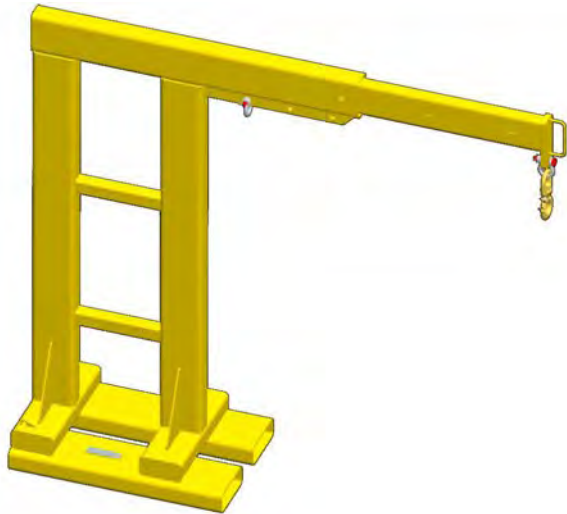

RFID TRACKING



CHIP EQUIPPED

- **Part Number 16055**
- Converts forklift into aerial crane.
- Fork Width : 6"
- Adjustable boom spacing at 48", 60" and 72"
- Boom comes equipped with alloy swivel latching hook.
- Weighs 375 pounds.

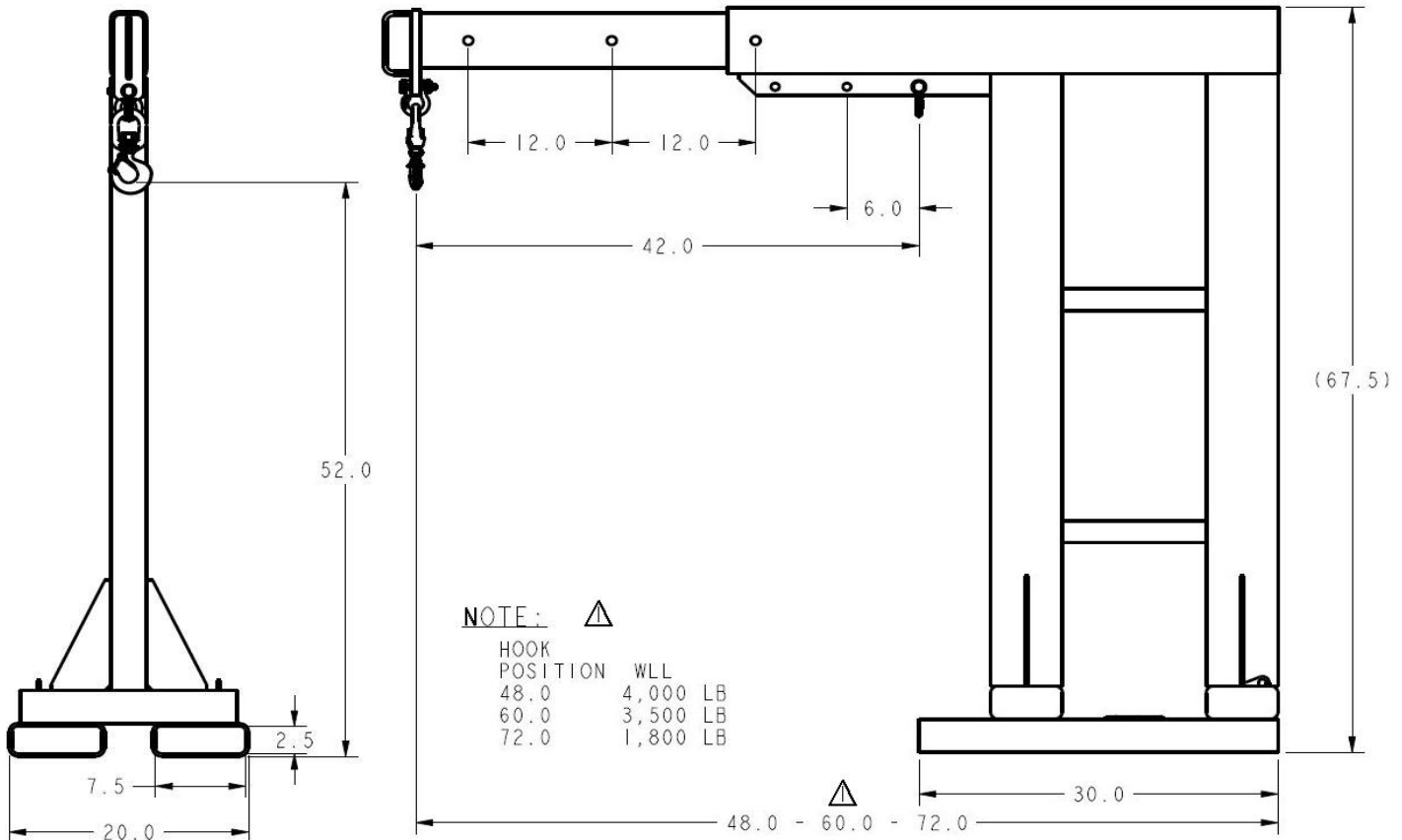



Forklift Attachments Forklift Pocket Lifters

Forklift Pocket Lifters

- Manufactured to exceed all ASME B30.20 and OSHA regulations.
- Painted safety yellow for increased visibility.
- **ALL** forklift attachments proof loaded and shipped with certification paperwork.
- Durable construction ideally suited to jobsite or warehouse use.
- Includes forklift restraining tabs.
- Made in U.S.A.
- Machined to exacting tolerances.
- Custom lettering available - call for details.
- Custom designs available - call for engineering.
- **ALL** lifting equipment individually proof loaded per OSHA requirements.
- Check with manufacturer of your forklift for load capabilities.

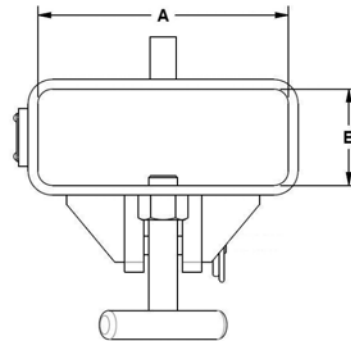
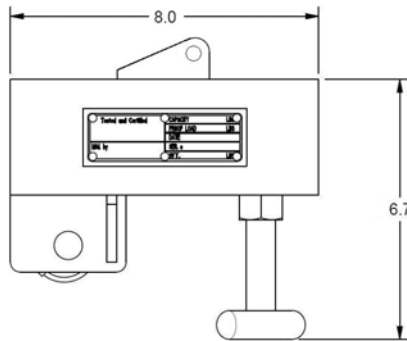

RFID TRACKING



CHIP EQUIPPED

Working Load Limit in Pounds*	Part Number	A	B	Fork Width	Weight
3,000	11606	4.5	2.5	4	12
3,000	11607	5.5	2.5	5	13
3,000	11608	6.5	2.5	6	14
3,000	15427	7.5	2.5	7	15
5,000	14259	4.5	2.5	4	16
5,000	14250	5.5	2.5	5	18
5,000	14262	6.5	2.5	6	20
7,000	15764	6.5	2.5	6	56
7,000	16642	7.5	3.5	7	56
7,000	16643	8.5	3.5	8	56

* Call for specifications on larger sizes and capacities

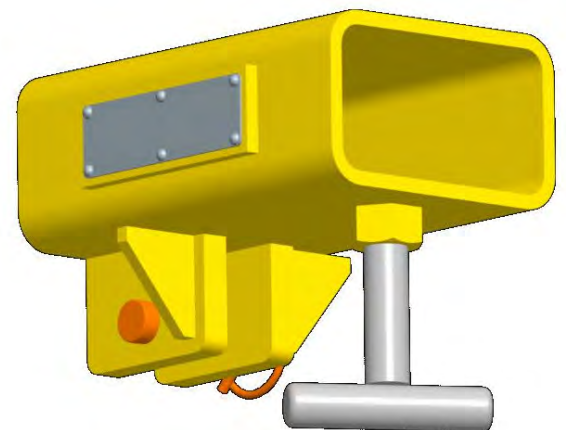
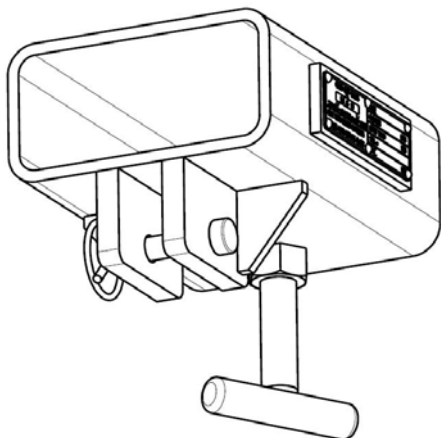

FORKLIFT ATTACHMENTS