

SS-125UNC

- All components are 316 stainless steel, except bolt retainers, which are made from 15-7 PH (UNS 15700) magnetic stainless steel.
- Available in capacities from 400 lbs. to 50,000 lbs.
- Rated at 100 percent at 90 degree angle.
- Each product has a Product Identification Code (PIC) for material traceability, along with the Working Load Limit and the name Crosby or "CG" stamped into it.
- Individually proof tested to 2 times the Working Load Limit with certification
- Fatigue Rated to 20,000 cycles at 1-1/2 times the Working Load Limit.
- Washer is color coded for easy identification (Red - UNC thread)
- Bolt specification is 316 Stainless Steel socket head cap screw to ASTM F 837M (316).
- All threads listed are Metric UNC.
- **BOLT SIZE IDENTIFICATION:** The size of the bolt will be stated as in the drawing above. Illustration shows meaning of each dimension given.
- **NOTE:** For Special Applications, see page 457.
- Frame 2 and larger are **RFID EQUIPPED**.



SS-125UNC Threads

Frame Size No.	SS-125UNC Stock No.	Working Load Limit (lb)*	Torque (ft-lbs)	Dimensions (in)								Weight Each (lb)
				Bolt Size A ‡	Effective Thread Projection Length B	C	D	Radius E	Diameter F	G	H	
1	1065000	400	3.5	5/16 - 18 x 1.0	.29	2.67	.85	.43	.34	1.84	1.27	.30
1	1065004	400	3.5	5/16 - 18 x 1.25	.54	2.67	.85	.43	.34	1.84	1.27	.30
1	1065008	500	6	3/8 - 16 x 1.25	.54	2.67	.85	.43	.34	1.84	1.27	.30
2	1065016	1250	14	1/2 - 13 x 2.0	.78	4.78	1.45	.88	.69	3.52	2.31	2.6
2	1065020	1250	14	1/2 - 13 x 2.25	1.03	4.78	1.45	.88	.69	3.52	2.31	2.6
2	1065024	1250	14	1/2 - 13 x 2.5	1.28	4.78	1.45	.88	.69	3.52	2.31	2.6
2	1065028	2000	30	5/8 - 11 x 2.0	.78	4.78	1.45	.88	.69	3.52	2.18	2.6
2	1065032	2000	30	5/8 - 11 x 2.25	1.03	4.78	1.45	.88	.69	3.52	2.18	2.6
2	1065036	2000	30	5/8 - 11 x 2.5	1.28	4.78	1.45	.88	.69	3.52	2.18	2.6
2	1065040	2500	50	3/4 - 10 x 2.25	1.03	4.78	1.45	.88	.69	3.52	2.06	3.0
2	1065044	2500	50	3/4 - 10 x 2.75	1.53	4.78	1.45	.88	.69	3.52	2.06	3.0
3	1065048	3500	50	3/4 - 10 x 2.75	1.04	6.52	2.20	1.40	.94	5.14	3.06	7.0
3	1065052	3500	50	3/4 - 10 x 3.25	1.54	6.52	2.20	1.40	.94	5.14	3.06	7.0
3	1065056	4000	80	7/8 - 9 x 2.75	1.04	6.52	2.20	1.40	.94	5.14	2.93	7.0
3	1065060	4000	80	7/8 - 9 x 3.0	1.29	6.52	2.20	1.40	.94	5.14	2.93	7.0
3	1065064	5000	115	1 - 8 x 3.0	1.29	6.52	2.20	1.40	.94	5.14	2.81	7.5
3	1065068	5000	115	1 - 8 x 3.25	1.54	6.52	2.20	1.40	.94	5.14	2.81	7.5
3	1065072	5000	115	1 - 8 x 4.0	2.29	6.52	2.20	1.40	.94	5.14	2.81	7.5
4	1065080	7500	235	1-1/4 - 7 x 4.0	1.89	8.73	3.19	1.75	1.25	6.50	4.12	14.0
5	1065084	12000	400	1-1/2 - 6 x 5.5	2.70	12.47	4.87	2.25	1.75	8.55	6.41	34.0
5	1065088	15000	550	2 - 4.5 x 5.75	2.96	12.47	4.87	2.25	1.75	8.55	5.91	36.0
6	1065092	25000	1050	2-1/2 - 4 x 8.0	4.00	16.87	6.52	3.00	2.25	11.67	8.03	88.0
6	1065096	25000	1050	2-1/2 - 8 x 8.0	4.00	16.87	6.52	3.00	2.25	11.67	8.03	88.0
7	1065100	37500	2150	3 - 4 x 10.25	5.00	19.50	8.10	3.75	2.75	14.15	8.48	166.0
8	1065104	50000	2550	3-1/2 - 4 x 13	7.00	22.09	8.60	4.00	3.25	15.90	9.28	265.0

*Ultimate Load is 5 times the Working Load Limit.

‡ Bolt specification is 316 Stainless Steel socket head cap screw to ASTM F 837 Group 1 (316).



Stainless Steel Swivel Hoist Rings



SS-125M

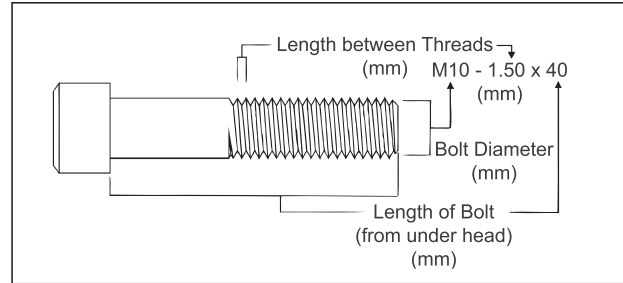
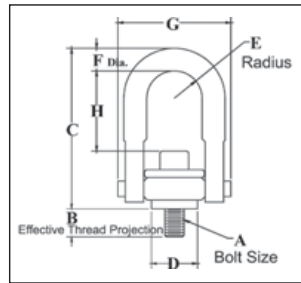

- All components are 316 stainless steel, except bolt retainers, which are made from 15-7 PH (UNS 15700) magnetic stainless steel.
- Available in capacities from 200 kg to 22,300 kg.
- Rated at 100 percent at 90 degree angle.
- Each product has a Product Identification Code (PIC) for material traceability, along with the Working Load Limit and the name Crosby or "CG" stamped into it.
- Individually proof tested to 2 times the Working Load Limit with certification
- Fatigue Rated to 20,000 cycles at 1-1/2 times the Working Load Limit.
- Washer is color coded for easy identification (Silver - Metric thread)
- Bolt specification is 316 Stainless Steel socket head cap screw to ASTM F 837M (316).
- All threads listed are Metric (ASME/ANSI B18.3.1M).
- **BOLT SIZE IDENTIFICATION:** The size of the bolt will be stated as in the drawing above. Illustration shows meaning of each dimension given.
- **NOTE:** For Special Applications, see page 457.
- Frame 2 and larger are **RFID EQUIPPED**.

Rigging Accessories

Fatigue Rated  **Load Rated**

SEE APPLICATION AND WARNING INFORMATION
On Pages 210 -211
Para Español: www.thecrosbygroup.com

SS-125M Metric Threads

Frame Size No.	SS-125M Stock No.	Working Load Limit (kg)*	Torque in (Nm)	Dimensions (mm)								Weight Each (kg)
				Bolt Size A ‡	Effective Thread Projection Length B	C	D	Radius E	Diameter F	G	H	
1	1065203	200	4	M8 x 1.25	13	68	21.6	11	8.5	47	32	.17
1	1065207	250	8	M10 x 1.50	18	68	21.6	11	8.5	47	30	.17
2	1065211	525	18	M12 x 1.75	19	121	37	22	17.5	89	60	1.1
2	1065215	950	40	M16 x 2.00	29	121	37	22	17.5	89	56	1.1
2	1065219	1075	68	M20 x 2.50	34	121	37	22	17.5	89	52	1.2
3	1065223	1500	68	M20 x 2.50	32	166	56	36	25	131	78	3.0
3	1065227	2100	108	M24 x 3.00	37	166	56	36	25	131	74	3.1
3	1065231	2100	108	M30 x 3.50	58	206	56	36	25	131	108	3.1
4	1065235	3500	318	M30 x 3.50	42	222	81	45	31	165	106	6.3
4	1065239	3500	318	M30 x 3.50	62	222	81	45	31	165	106	6.4
5	1065243	5500	542	M36 x 4.00	64	317	124	57	43	217	166	15.5
5	1065247	6250	542	M42 x 4.50	82	317	124	57	43	217	160	16.0
5	1065251	6750	542	M48 x 5.00	82	317	124	57	43	217	154	16.8
6	1065255	11150	1423	M64 x 6.00	101	428	165	76	56	296	204	39.0
7	1065259	15750	2915	M72 x 6.00	132	495	206	95	69	359	220	74.0
8	1065263	22300	3459	M90 x 6.00	177	561	216	102	83	404	235	118.0

*Ultimate Load is 5 times the Working Load Limit. ‡ Bolt specification is 316 Stainless Steel socket head cap screw to ASTM F 837M Group 1 (316).



CROSBY SWIVEL HOIST RING

WARNING & APPLICATION INSTRUCTIONS



HR-125/SS-125
(Red Washer)
HR-125M
SS-125M
(Silver Washer)



HR-1000
(Red Washer)
HR-1000M
(Silver Washer)
HR-1000CT
(Blue Washer)

Hoist Ring Application Assembly Safety

Use swivel hoist ring only with a ferrous metal (steel, iron) or soft metal (i.e., aluminum) load (workpiece). Do not leave threaded end of hoist ring in aluminum loads for long time periods due to corrosion.

For subsea or marine environment applications, use the HR-1000CT series Hoist Ring only.

- After determining the loads on each hoist ring, select the proper size hoist ring using the Working Load Limit ratings in Tables 1, 2, and 5 for UNC threads and Tables 3, 4 and 6 for Metric threads (on next page).
- Drill and tap the workpiece to the correct size to a minimum depth of one-half the threaded shank diameter plus the threaded shank length. See rated load limit and bolt torque requirements imprinted on top of the swivel trunnion (See Table 1 through Table 6 on next page).
- When a hoist ring is used in a side load application, ensure equal loading on the pins by aligning the bail as shown in (Fig. 3).
- Always be sure total hoist ring bushing mating surface is in contact with the (workpiece) surface. Drilled and tapped hole must be 90 degrees to load (workpiece) surface.
- Install hoist ring to recommended torque with a torque wrench making sure the bushing flange meets the load (workpiece) surface.
- Never use spacers between bushing flange and mounting surface.
- Always select proper load rated lifting device for use with Swivel Hoist Ring.
- Attach lifting device ensuring free fit to hoist ring bail (lifting ring) (Fig. 1).
- Apply partial load and check proper rotation and alignment. There should be no interference between load (workpiece) and hoist ring bail (Fig. 2).
- Special Note: When a Hoist Ring is installed with a retention nut, the nut must have a full thread engagement and must meet one of the following standards to develop the Working Load Limit (WLL).

UNC NUTS

- 1. ASTM A-563**
Grade D
(Heavy Hex or Hex Thick)
Grade DH
Grade DH3
- 2. ASTM A-194**
Grade 2H
Grade 4
Grade 7
- 3. FNL**
Grade 9
- 4. SAE J995**
Grade 8

METRIC NUTS

- 1. ASTM A-563M**
Class 10S
- 2. ISO 898-2**
(EN 20898-2/DIN 267-4)
Class 10
Class 12

Hoist Ring Inspection / Maintenance

- Always inspect hoist ring before use.
- Regularly inspect hoist ring parts.
- Never use hoist ring that shows signs of corrosion, wear or damage.
- Never use hoist ring if bail is bent or elongated.
- Always be sure threads on shank and receiving hole are clean, not damaged, and fit properly.

- Always check with torque wrench before using an already installed hoist ring.
- Always make sure there are no spacers (washers) used between bushing flange and the mounting surface. Remove any spacers (washers) and retorque before use.
- Prior to loading always ensure free movement of bail. The bail should pivot 180 degrees and swivel 360 degrees.

WARNING

- **Loads may slip or fall if proper Hoist Ring assembly and lifting procedures are not used.**
- **A falling load may cause serious injury or death.**
- **Install hoist ring bolt to torque requirements listed in tables 1, 2, 3, 4, 5, & 6 for the HR-125, HR-1000, HR-1000CT, HR-125M, HR-1000M and SS-125.**
- **Read, understand and follow all instructions and chart information.**
- **Do not use with damaged slings, chain, or webbing. For inspection criteria see ASME B30.9.**
- **Use only genuine Crosby parts as replacements.**

Operating Safety

- Never exceed the capacity of the swivel hoist ring, see Tables 1, 2 and 5 for UNC threads and Tables 3, 4 and 6 for Metric threads. (See next page for tables.)
- When using lifting slings of two or more legs, make sure the forces in the legs are calculated using the angle from the horizontal sling angle to the leg and select the proper size swivel hoist ring to allow for the angular forces.

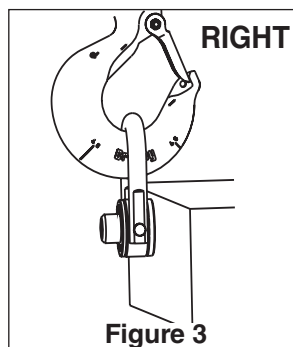
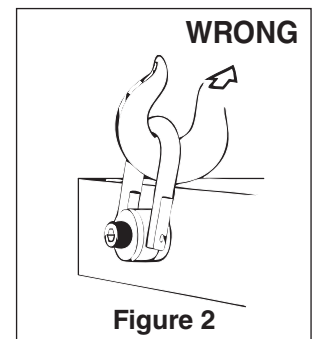
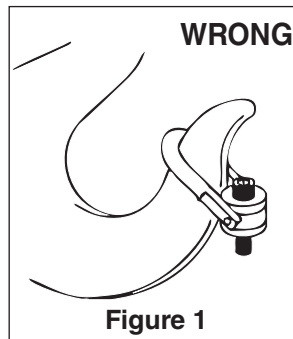
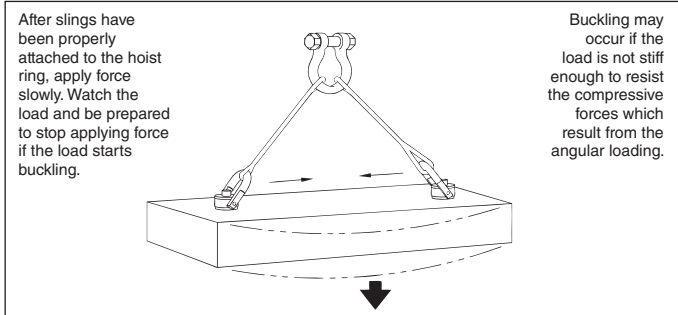
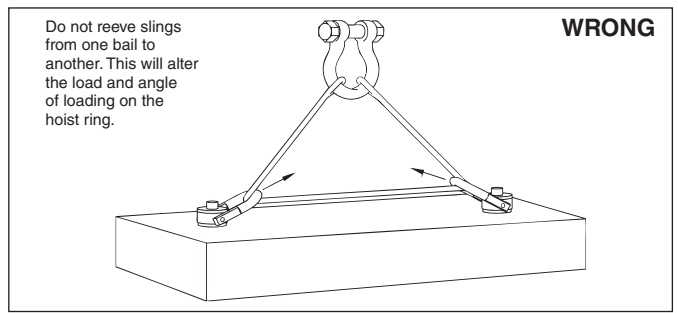

Table 1					
Working Load Limit* 5:1 (lb)	Hoist Ring Bolt Torque (ft•lbf) †	HR-125		HR-1000	
		Bolt Size ‡ (in)	Effective Thread Projection Length (in)	Bolt Size ‡ (in)	Effective Thread Projection Length (in)
800 ††	7	5/16 - 18 x 1.50	.58	5/16 - 18 x 1.50	.52
1000 ††	12	3/8 - 16 x 1.50	.58	3/8 - 16 x 1.50	.52
2500	28	1/2 - 13 x 2.00	.70	1/2 - 13 x 2.25	.69
2500 ††	28	1/2 - 13 x 2.50	1.20	1/2 - 13 x 2.75	1.19
4000	60	5/8 - 11 x 2.00	.70	5/8 - 11 x 2.25	.69
4000 ††	60	5/8 - 11 x 2.75	1.45	5/8 - 11 x 3.00	1.44
5000	100	3/4 - 10 x 2.25	.95	3/4 - 10 x 2.50	.94
5000 ††	100	3/4 - 10 x 2.75	1.45	3/4 - 10 x 3.00	1.44
7000 Ω	100	3/4 - 10 x 2.75	.89	3/4 - 10 x 3.00	.85
7000 ††Ω	100	3/4 - 10 x 3.50	1.64	3/4 - 10 x 3.50	1.35
8000	160	7/8 - 9 x 2.75	.89	7/8 - 9 x 3.00	.85
8000 ††	160	7/8 - 9 x 3.50	1.64	7/8 - 9 x 3.50	1.35
10000	230	1 - 8 x 3.00	1.14	1 - 8 x 4.50	1.35
10000 ††	230	1 - 8 x 4.00	2.14	1 - 8 x 4.50	2.35
15000	470	1-1/4 - 7 x 4.50	2.21	1-1/4 - 7 x 5.00	2.09
24000	800	1-1/2 - 6 x 6.75	2.97	1-1/2 - 6 x 5.50	2.59
30000	1100	2 - 4-1/2 x 6.75	2.97	—	—
50000	2100	2-1/2 - 4 x 8.00	4.00	—	—
75000	4300	3 - 4 x 10.50	5.00	—	—
100000	5100	3-1/2 - 4 x 13.00	7.00	—	—



Ω Ultimate Load is 4.5 times Working Load Limit for 7000# Hoist Ring when tested in 90° orientation. All sizes are individually proof tested to 2-1/2 times the Working Load Limit. *, †, ††, ‡ (See footnotes at bottom of Table 5).

Table 2				
Working Load Limit (kg) ****		HR-1000MCT		
Design Factor 5:1	Design Factor 4:1	Hoist Ring Bolt Torque in (Nm) †	Bolt Size (mm) ‡	Effective Thread Projection Length (mm)
825	1030	38	M12 x 1.75 x 55	15.6
1350	1690	81	M16 x 2.00 x 65	25.5
2250	2810	136	M20 x 2.50 x 80	25.3
3175	3970	312	M24 x 3.00 x 90	35.4
5450	6810	637	M30 x 3.50 x 140	65.9
7450	9310	1005	M36 x 4.00 x 130	56.3
13250	16560	1350	M48 x 5.00 x 180	50.7

Table 3			
HR-1000CT			
Working Load Limit 5:1 (lb) ****	Hoist Ring Bolt Torque in (ft•lbf) †	Bolt Size (in) Δ	Effective Thread Projection Length (in)
1900	28	1/2 - 13 x 2.25	.70
1900	28	1/2 - 13 x 2.75	1.20
3000	60	5/8 - 11 x 2.25	.70
4800	100	3/4 - 10 x 3.00	.85
6200	160	7/8 - 9 x 3.00	.85
8300	230	1 - 8 x 3.50	1.35
12500	470	1 1/4 - 7 x 5.00	2.10
20000	800	1 1/2 - 6 x 5.50	2.60
20000	800	1 1/2 - 8 x 5.50	2.60
28000	1100	2 - 4.5 x 7.50	3.20
45000	2100	2 1/2 - 4 x 9.50	3.73

Table 4						
Working Load Limit (kg)***		Hoist Ring Bolt Torque in (Nm) †	HR-125M		HR-1000M	
Design Factor 5:1	HR-125M Design 4:1		Bolt Size ‡ (mm)	HR-125M Effective Thread Projection Length (mm)	Bolt Size ‡ (mm)	HR-1000M Effective Thread Projection Length (mm)
400	500	10	M 8 X 1.25 X 40	16.9	M 8 X 1.25 X 40	15.2
450	550	16	M 10 X 1.50 X 40	16.9	M 10 X 1.50 X 40	15.2
1050	1300	38	M 12 X 1.75 X 50	17.2	M 12 X 1.75 X 55	15.5
1900	2400	81	M 16 X 2.00 X 60	27.2	M 16 X 2.00 X 65	25.5
2150	2700	136	M 20 X 2.50 X 65	31.2	M 20 X 2.50 X 70	30.5
3000	3750	136	M 20 X 2.50 X 75	28.1	M 20 X 2.50 X 80	25.4
4200	5250	312	M 24 X 3.00 X 80	33.1	M 24 X 3.00 X 90	35.4
7000	8750	637	M 30 X 3.50 X 120	65.1	M 30 X 3.50 X 140	66.2
11000	13750	1005	M 36 X 4.00 X 150	60.6	M 36 X 4.00 X 150	56.2
12500	15600	1005	M 42 x 4.50 x 160	70.6	—	—
13500	16900	1350	M 48 x 5.00 x 160	101	—	—
22300	27900	2847	M 64 x 6.00 x 204	101	—	—
31500	39400	5830	M 72 x 6.00 x 265	132	—	—
44600	55800	6914	M 90 x 6.00 x 330	177	—	—

See Footnotes on next page.

† Tightening torque values shown are based upon threads being clean, dry and free of lubrication.

Footnotes below relate to tables 1-4

* Ultimate load is 5 times the Working Load Limit. Individually proof tested to 2-1/2 times the Working Load Limit.

** Ultimate load is 4 times the Working Load Limit. Individually proof tested to 2-1/2 times the Working Load Limit.

*** Individually proof tested to 2-1/2 times the Working Load Limit based on 4:1 design factor

**** Ultimate load is 5 times the Working Load Limit. Individually proof tested to 2 times the Working Load Limit.

†† Long bolts are designed to be used with soft metal (i.e., aluminum) workpiece. While the long bolts may also be used with ferrous metal (i.e., steel & iron) workpieces, short bolts are designed for ferrous workpieces only.

‡ Bolt specification is a Alloy socket head cap screw to ASTM A574. All threads are UNC .

‡‡ Bolt specification is a Grade 12.9 Alloy socket head cap screw to DIN 912. All threads are metric (ASME/ANSI B18.3.1m)

△ Bolt specification is a Grade L7 or L43 Alloy socket head cap screw to ASTM A320. All threads are UNC.

‡‡‡ Tighten bolt to specified torque, then tighten nut to specified torque.

All Swivel Hoist Rings are individually proof tested.

Table 5			
SS-125 ¥¥			
Working Load Limit (lb) ¥	Torque in (ft•lbf) †	Bolt Size (in) §	Effective Thread Projection (in)
400	3.5	5/16 - 18 x 1	.29
400	3.5	5/16 - 18 x 1.25	.54
500	6	3/8 - 16 x 1.25	.54
1250	14	1/2 - 13 x 2	.78
1250	14	1/2 - 13 x 2.25	1.03
1250	14	1/2 - 13 x 2.5	1.28
2000	30	5/8 - 11 x 2	.78
2000	30	5/8 - 11 x 2.25	1.03
2000	30	5/8 - 11 x 2.5	1.28
2500	50	3/4 - 10 x 2.25	1.03
2500	50	3/4 - 10 x 2.75	1.53
3500	50	3/4 - 10 x 2.75	1.04
3500	50	3/4 - 10 x 3.25	1.54
4000	80	7/8 - 9 x 2.75	1.04
4000	80	7/8 - 9 x 3	1.29
5000	115	1 - 8 x 3	1.29
5000	115	1 - 8 x 3.25	1.54
5000	115	1 - 8 x 4	2.29
7500	235	1-1/4 - 7 x 4	1.89
12000	400	1-1/2 - 6 x 5.5	2.70
15000	550	2 - 4-1/2 x 5.75	2.96
25000	1050	2-1/2 - 4 x 8	4.00
25000	1050	2-1/2 - 8 x 8	4.00
37500	2150	3 - 4 x 10.25	5.00
50000	2550	3-1/2 - 4 x 13	7.00

Table 6			
SS-125M ¥¥			
SS-125M ¥¥ Working Load Limit (kg) ¥	Torque in Lbs. †	Bolt Size (mm) §§	Effective Thread Projection (mm)
200	4	M 8 x 1.25x30	13
250	8	M 10 x 1.50x35	18
525	18	M 12 x 1.75x50	19
950	40	M 16 x 2.00x60	29
1075	68	M 20 x 2.50x65	34
1500	68	M 20 x 2.50x75	32
2100	108	M 24 x 3.00x80	37
2100	108	M 30 x 3.50x110	58
3500	318	M 30 x 3.50x95	42
3500	318	M 30 x 3.50x115	62
5500	542	M 36 x 4.00x135	64
6250	542	M 42 x 4.50x155	82
6750	746	M 48 x 5.00x155	82
11150	1423	M 64 x 6.00x205	101
15750	2915	M 72 x 6.00x265	132
22300	3459	M 90 x 6.00x330	177

Footnotes below relate to Tables 5 and 6

¥ Ultimate load is 5 times the Working Load Limit. Individually proof tested to 2 times the Working Load Limit.

¥¥ All components are 316 Stainless Steel, except Bolt Retainers, which are made from 15-7 PH (UNS 15700) magnetic stainless steel.

§ Bolt specification is 316 Stainless Steel socket head cap screw to ASTM F837 Group 1 (316).

§§ Bolt specification is 316 Stainless Steel socket head cap screw to ASTM F837M (316). All threads are Metric (ASME/ANSI B18.3.1M).