

L-320CN
Frame Size D-N



- Available in carbon steel and alloy steel.
- Eye hooks are load rated (marked with the Working Load Limit).
- Fatigue rated to 20,000 cycles at 1.5 times the Working Load Limit.
- Chemical analysis and tensile tests performed on each PIC to verify chemistry and mechanical properties.
- Hooks incorporate QUIC-CHECK® deformation and angle indicators. (For detailed information, see the Crosby Value Added page at the beginning of this section.)

L-320C
Frame Size O-T



APPLICATION AND WARNING INFORMATION
SECTION 17

L-320N / L-320 Eye Hooks

Working Load Limit (t)		Hook ID Code	Eye Hook Stock No.			Weight Each (lb)	Replacement Latch Kits		
Carbon	Alloy		Carbon L-320C L-320CN S.C.	Carbon GL-320CN Galv.	Alloy L-320A L-320AN S.C.		S-4320 Stock No.	PL Stock No.	SS-4055 Stock No.
0.75	1	†D	1022205	1022208	1022380	.61	1096325	-	-
1	1.5	†F	1022216	1022219	1022391	.89	1096374	-	-
1.5	2	†G	1022227	1022230	1022402	1.44	1096421	-	-
2	3	†H	1022238	1022241	1022413	2.07	1096468	-	-
3	5	†I	1022246	1022249	1022424	4.30	1096515	1092000	-
5	7	†J	1022260	1022262	1022435	8.30	1096562	1092001	-
7.5	11	†K	1022271	1022274	1022446	15.00	1096609	1092002	-
10	15	†L	1022282	1022285	1022457	20.77	1096657	1092003	-
15	22	†N	1022293	1022296	1022468	39.50	1096704	1092004	-
20	30	O	1022302	-	1022477	60.00	-	1093716	1090161
25	37	P	1023306	-	1023565	105.00	-	1093717	1090189
40	45	S	1023324	-	1023583	148.00	-	1093718	1090189
40	60	T	1023342	-	1023609	228.00	-	1093719	1090205

All carbon hooks have a 5:1 Design Factor. Alloy eye hooks 1t through 22t have a 5:1 Design Factor. Alloy eye hooks 30t through 60t have a 4.5:1 Design Factor. For 3/4t carbon through 22t alloy eye hooks, Proof Load is 2.5 times Working Load Limit. For 20t carbon through 60t alloy eye hooks, Proof Load is 2 times Working Load Limit.

L-320AN
Frame Size D-N



L-320AN
Frame Size O-T

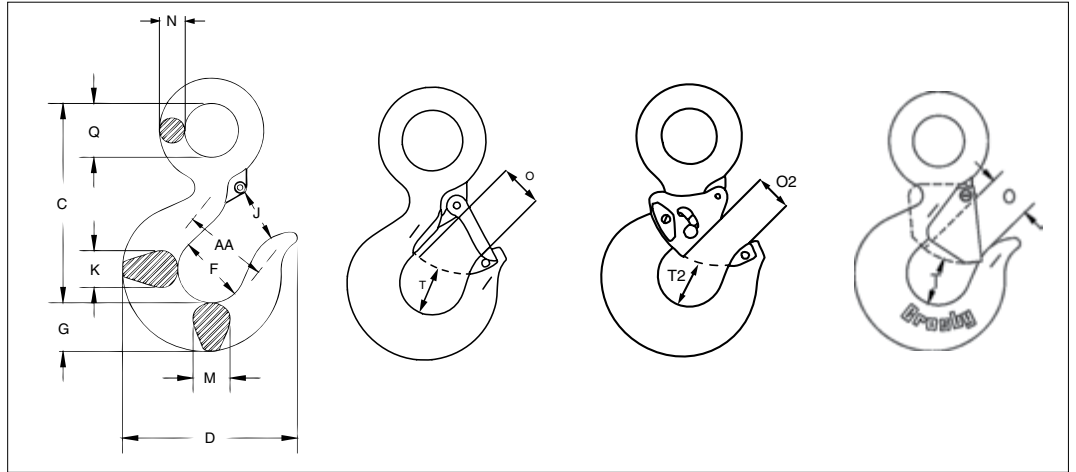

APPLICATION AND WARNING INFORMATION
SECTION 17

L-320N / L-320 Eye Hooks

Hook ID Code*	Dimensions (in)													
	C	D	F	G	J	K	M	N	O †	O2 ††	Q	T †	T2 ††	AA**
†D	3.34	2.83	1.25	.73	.90	.63	.63	.36	.89	-	.75	.87	-	1.50
†F	3.81	3.11	1.38	.84	.93	.71	.71	.42	.91	-	.91	.98	-	2.00
†G	4.14	3.53	1.50	1.00	1.00	.88	.88	.55	1.00	-	1.13	1.03	-	2.00
†H	4.69	3.97	1.63	1.13	1.13	.94	.94	.58	1.09	-	1.25	1.16	-	2.00
†I	5.77	4.81	2.00	1.44	1.47	1.31	1.31	.72	1.36	1.00	1.56	1.53	1.50	2.50
†J	7.37	6.27	2.50	1.81	1.75	1.66	1.66	.90	1.61	1.31	2.00	1.96	1.88	3.00
†K	9.07	7.45	3.00	2.25	2.29	1.88	1.63	1.11	2.08	1.81	2.44	2.47	2.25	4.00
†L	10.08	8.30	3.25	2.59	2.50	2.19	1.94	1.27	2.27	2.00	2.84	2.62	2.31	4.00
†N	12.53	10.30	4.25	3.00	3.30	2.69	2.38	1.56	3.02	2.75	3.50	2.83	2.56	5.00
O	14.06	13.62	5.00	3.62	4.00	3.00	3.00	1.75	3.25	-	3.50	3.44	-	6.50
P	18.19	14.06	5.38	4.56	4.25	3.75	3.19	2.00	3.00	-	4.50	3.88	-	7.00
S	20.12	15.44	6.00	5.06	4.75	4.50	3.25	2.18	3.38	-	4.94	4.75	-	8.00
T	23.72	18.50	7.00	6.00	5.75	5.50	3.91	2.53	4.12	-	5.69	5.69	-	10.00

*Deformation indicators. †3/4t carbon though 22t alloy dimensions shown are for S-4320 Latch Kits. Dimensions for "O" frame size and larger are for PL Latch Kits.
††Dimensions are for PL-N latch kits.