

HR-1000

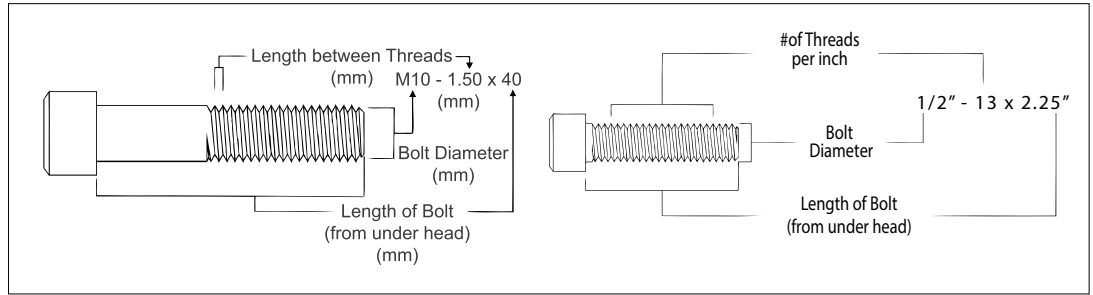

- Forged bail provides the following:
 - Easily readable raised lettering showing the name Crosby or "CG" and PIC for material traceability.
 - Greater durability providing the increased "Toughness" desired in potentially abusive field conditions.
 - Larger opening than standard hoist ring bail.
- Top washer is color-coded for easy identification (Red for UNC threads and Silver for Metric threads)
- The Working Load Limit and recommended torque value are permanently stamped into each washer.
- Individually Proof Tested to 2-1/2 times Working Load Limit.
- Available in both UNC thread and Metric thread style.
- UNC bolt specification is an alloy socket head cap screw to ASTM A 574. Metric bolt specification is a Grade 12.9 alloy socket head cap screw to DIN 912.
- BOLT SIZE IDENTIFICATION: The size of the bolt will be stated as in the drawing. Illustration shows meaning of each dimension given.

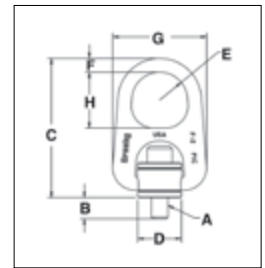

HR-1000 UNC Threads

Frame Size No.	Stock No.	Working Load Limit (lb)	Torque in Ft. Lbs	Dimensions (in)									Weight Each (lb)
				Bolt Size A	Eff. Thread Projection Length B	C	D	Radius E	F	G	H		
1	1068002	800	7	5/16 - 18 x 1.50	.52	3.69	.97	.62	.44	2.27	1.38	.60	
1	1068006	1000	12	3/8 - 16 x 1.50	.52	3.69	.97	.62	.44	2.27	1.38	.62	
2	1068010	2500	28	1/2 - 13 x 2.25	.69	6.26	1.96	1.25	.75	4.20	2.50	3.05	
2 †	1068014	2500	28	1/2 - 13 x 2.75	1.19	6.26	1.96	1.25	.75	4.20	2.50	3.07	
2	1068018	4000	60	5/8 - 11 x 2.25	.69	6.26	1.96	1.25	.75	4.20	2.50	3.11	
2 †	1068022	4000	60	5/8 - 11 x 3.00	1.44	6.26	1.96	1.25	.75	4.20	2.50	3.18	
2	1068026	5000	100	3/4 - 10 x 2.50	.94	6.26	1.96	1.25	.75	4.20	2.50	3.24	
2 †	1068030	5000	100	3/4 - 10 x 3.00	1.44	6.26	1.96	1.25	.75	4.20	2.50	3.30	
3	1068034	7000*	100	3/4 - 10 x 3.00	.85	8.66	2.96	1.63	1.00	6.25	3.25	10.09	
3 †	1068038	7000*	100	3/4 - 10 x 3.50	1.35	8.66	2.96	1.63	1.00	6.25	3.25	10.21	
3	1068042	8000	160	7/8 - 9 x 3.00	.85	8.66	2.96	1.63	1.00	6.24	3.25	10.21	
3 †	1068046	8000	160	7/8 - 9 x 3.50	1.35	8.66	2.96	1.63	1.00	6.24	3.25	10.40	
3	1068050	10000	230	1 - 8 x 3.50	1.35	8.66	2.96	1.63	1.00	6.24	3.25	10.50	
3 †	1068054	10000	230	1 - 8 x 4.50	2.35	8.66	2.96	1.63	1.00	6.24	3.25	10.72	
4	1068058	15000	470	1-1/4 - 7 x 5.00	2.09	11.21	3.71	2.00	1.25	7.82	4.00	21.90	
4	1068062	24000	800	1-1/2 - 6 x 5.50	2.59	11.21	3.71	2.00	1.44	7.82	4.00	23.00	

5:1 Design Factor. *4.5:1 Design Factor when tested in 90 degree orientation. †Long Bolts are designed to be used with soft metal (i.e., aluminum) workpiece.

HR-1000M Metric Threads

Frame Size No.	Stock No.	Working Load Limit (kg)		Torque in Nm	Dimensions (mm)									Weight Each (kg)
		At a 5:1 Design Factor*	At a 4:1 Design Factor*		Bolt Size A	Eff. Thread Projection Length B	C	D	Radius E	F	G	H		
1	1068307	400	500	10	M8 x 1.25 x 40	15.2	93.7	24.6	15.7	11.2	57.7	35.1	0.3	
1	1068316	450	550	16	M10 x 1.50 x 40	15.2	93.7	24.6	15.7	11.2	57.7	35.1	0.3	
2	1068325	1050	1300	38	M12 x 1.75 x 55	15.5	162	49.8	31.8	19.1	107	63.5	1.5	
2	1068334	1900	2400	81	M16 x 2.00 x 65	25.5	162	49.8	31.8	19.1	107	63.5	1.5	
2	1068343	2150	2700	136	M20 x 2.50 x 70	30.5	162	49.8	31.8	19.1	107	63.5	1.6	
3	1068352	3000	3750	136	M20 x 2.50 x 80	25.4	220	75.2	41.4	25.4	159	82.6	4.6	
3	1068361	4200	5250	312	M24 x 3.00 x 90	35.4	220	75.2	41.4	25.4	159	82.6	4.8	
4	1068370	7000	8750	637	M30 x 3.50 x 140	66.2	285	94.2	50.8	31.8	199	102	9.7	
4	1068389	11000	13750	1005	M36 x 4.00 x 130	56.2	285	94.2	50.8	31.8	199	102	10.2	

*Individually proof loaded to 2-1/2 times the Working Load Limit based on the 4:1 Design Factor.

