



Distributed By

## WESTECH RIGGING SUPPLY

Visit Us Online at: [www.WestechRigging.com](http://www.WestechRigging.com)

Call Us Toll Free at: 800-442-7475

Call Us or Visit Our Stores: Monday - Friday, 8:00am - 5:30pm Pacific

4140 West 11th Avenue

Eugene, Oregon 97402

2439 McGilchrist St SE

Salem, Oregon 97302



# LINEMAN'S PRODUCT GUIDE



**LINEMAN'S STRAP HOISTS**

**CABLE HOISTS**

**HAND CHAIN HOISTS**

**SLINGS**

**WIRE GRIPS**

**LIFTING TONGS**

**CANT HOOKS**

**PEAVIES**

**PIKE POLES**





## 250A & 300A MODELS

The Lineman's Standard

### Capacities

Rated loads of 1000 and 1500 lbs.- single line; 2000 and 3000 lbs.- double line.

### Overload Protection

Handle bends to warn of hazardous condition and prevents dangerous overload.

### Hooks with Latches

360° swiveling hooks equipped with latches for positive load engagement.

### Positive Load Holding

Positive load holding in all environments. Double, interlocking pawl mechanism assures one pawl is engaged at all times.

### Lightweight & Rugged

Special cast aluminum and zinc alloy housings.

### Corrosion Resistant

All stainless steel springs and shafts.

### Reduced Wear

All rotating shafts are mounted on bronze bushings.

### Meets or Exceeds

Minimum 4:1 design factor and all requirements of ASME/ ANSI Standard B-30.21. All units tested at 125% of rated load.



## 322B & 344B MODELS

Advanced & Refined

### Capacities

Rated loads of 1500 and 2000 lbs.- single line; 3000 and 4000 lbs.- double line.

### Overload Protection

Handle tip bends to warn of hazardous overload. Handle tip replacement is easy and simple.

### Enhanced Reversing Mechanism

Innovative design reduces the handle effort needed to release or lower a load. Double interlocking pawls assures positive load holding in all environments.

### Compact Aluminum Alloy Frame

Features a double flanged strap drum and interrogated hook point for double line use.

### Corrosion Resistant

All stainless steel springs and shafts.

### Reduced Wear

All rotating shafts are mounted on bronze bushings.

### Hooks with Latches

360° swiveling hooks can be equipped with a wide range of latch options.

### Meets or Exceeds

Minimum 4:1 design factor and all requirements of ASME/ ANSI Standard B-30.21. All units tested at 125% of rated load.



See back for Strap Hoist hook options



## 6000A MODEL

The Transmission Specialist

- 6000 lb. Capacity, strongest Web Strap Puller available
- Extra large superior grade webbing with double side plate housing design.
- Positive load holding in all environments, provided by double interlocking pawl mechanism.
- Extremely low handle effort, provided by special 4:1 gear reduction.



## Wire Grips

Rigging Products

- Forged steel construction, durable yet lightweight.
- Yellow Chromate finish protects components from rust and corrosion.
- All model are rated for a wide range of wire sizes – few grip changes.
- No lock up, grips can be opened and removed from the wire quickly.

See back for grip types & jaw options



## RA 3/4 - 6 Ton

Ratchet Lever Hoist

- Standard lift is 5 feet.
- Dual ratchet and pawl design provides easy operation.
- Link chain.
- Aluminum housing.
- Multiple rigging options.



## G Model 3/4 - 15 Ton

Ratchet Lever Hoist

- Standard lift is 5 feet.
- Single or double-locking pawl models available.
- Can be used to lift or pull.
- Easy operation from either side.
- Roller chain.
- Malleable iron housing.



## LMSC 3/4 - 6 Ton

Ratchet Lever Hoist

- Standard lifts are 5, 10, 15 and 20 feet.
- Low handle effort.
- Short 360° rotating handle assures precise positioning.
- Optional load limiter available.
- Easy to free chain.



## TB-602 550 lb.

## TB-603 1100 lb.

Ratchet Lever Hoists

- 5 ft. and 10 ft. lifts available.
- Hardend link-type steel load chain and Weston-type load brake are standard.
- Lightweight and compact. Easy tool box storage.



## LMR 3/4 - 3 Ton

Ratchet Lever Hoist

- Standard lifts are 5, 10, 15 and 20 feet.
- Easy to free chain.
  - Short handle with low handle effort.
  - Link chain.
  - Aluminum housing.



## Slings

Rigging Products

- Slings are available in many different styles
- Sizes range from 7/32" through 3/4"
- Working load limits available up to 91,700 lbs.
  - Specialty slings built to order.



## Cable Hoists

1/4 - 2 Ton

Wire Rope Hoist

- Single and double line.
- Reversible handle bends when overloaded.
- Lightweight and rugged.
- Meets ANSI/ASME Standard B-30.21.



## Lifting Tongs

Utility Products

- Certified and Proof Tested alloy product for overhead lifting; affixed with a permanent metal identification tag
- Tong shape has been designed to provide a sure grip on poles and logs.
- Meets the requirements of ASME B30.20 Below-the-Hook Lifting Devices, Group 1, Section 20-1.2.1 and 20-1.4 for marking and testing.



## Pikes & Midget Pike Poles

Utility Products

- Handles turned from second growth American ash with straight grain through entire handle length and air dried.
- Offered in lengths from 3 feet through 16 feet, normally in two foot increments.
- Pike hook manufactured from a single piece of high carbon steel and drop forged.
- Curved pike and hook and straight pike available on a special order basis.



## Cant Hooks & Peavies

Utility Products

- Handles turned from select White Mountain Hickory air dried to 18% moisture content.
- Precision fitted with the finest tool available to the industry.
  - Duckbill hooks are drop forged high carbon steel with the bill ground to a fine point.
  - This one piece unit makes field repairs easier.

# HOOK OPTIONS

For Strap Hoist Models



**B**

## Standard Hook

Forged steel hooks provide lasting strength and durability. Hooks will bend open under extreme overload situations. Latches are standard.



**DB**

## Hot Stick Hook

Hot Stick hooks have a welded ring for use with holding sticks. Latches are standard.



**CB**

## Swivel Gate Hook

Bullard-type, swivel gate latch provides positive locking action for secure load holding in all environments.



**DHB**

## Hot Stick Hook & Gate Latch

Hot Stick gate latch models have rings on the latch and the hook for use on energized lines. Holding sticks easily maneuver the latch and hooks.

# JAW OPTIONS

For Wire Grips



## BULLDOG-TYPE JAW

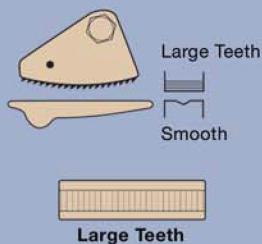

1000 & 2000 lb.

## PARALLEL JAW

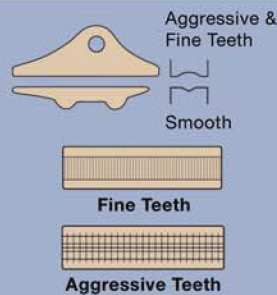

5000 & 10,000 lb.

## PARALLEL JAW

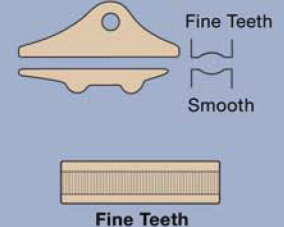

12,000 & 20,000 lb.

**LITTLE MULE**<sup>®</sup>  
Lineman's Products

Little Mule Lineman's Products



LMUPG-1207  
15M 12/07  
©2007 Little Mule Products  
Printed in USA