



# Plate Lifting Clamps Universal & Horizontal

½ to 5 Metric Ton Capacity

## FEATURES

- ▶ All steel body for durable strength in a smaller size.
- ▶ For use with material having surface hardness < HRC 37
- ▶ Minimum 10% WLL is required to ensure grip. (PCUA)
- ▶ 180° turning range for easy positioning or transfer of plates. (PCUA)
- ▶ Lever ensures pre-tensioning and release of grip jaws. (PCUA)
- ▶ Replacement parts and kits are available.
- ▶ Meets: EU Directives: 2006/42/EC and ASME B30.20.
- ▶ Individually serialized and tested to 2x WLL. Factory test certification of proof load is included.



## PCH Horizontal

Top Sling Angle	=	% Maximum Rated Capacity
0° to 60°	=	100%
60° to 90°	=	75%
90° to 120°	=	50%

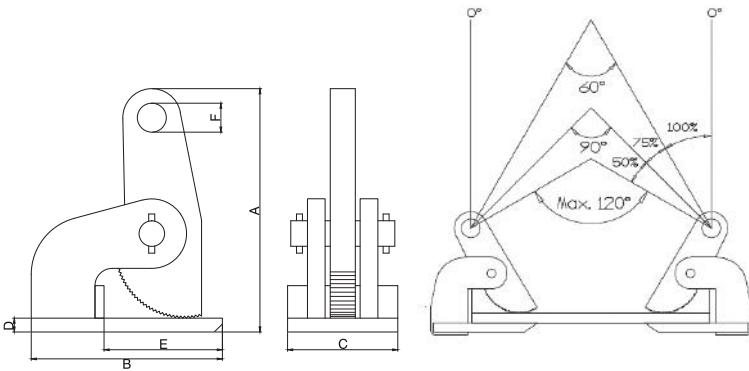

### PCH SERIES SPECIFICATIONS AND DIMENSIONS (inches)

Model#	WLL (pair) metric ton	Weight (lbs.)	Jaw Opening	A	B	C	D	E	F
PCH005	0.5t	6.2	0-1-3/8	6.61	5.51	2.56	0.47	3.86	0.79
PCH010	1.0t	13.2	0-2-3/8	10.43	7.09	2.95	0.47	4.33	0.98
PCH020	2.0t	16.5	0-2-3/8	10.43	7.09	3.15	0.63	4.33	0.98
PCH030	3.0t	22	0-2-3/8	12.01	8.66	3.54	0.70	5.31	1.18
PCH050	5.0t	34	0-2-3/8	12.01	8.66	4.33	0.98	4.92	1.18

Note: WLL rating is per pair (to be used in pairs only).

## PCUA Universal

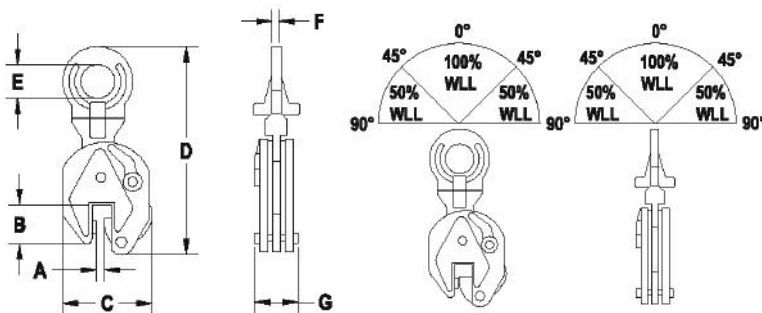

### PCUA SERIES SPECIFICATIONS AND DIMENSIONS (inches)

Model#	WLL metric ton	Weight (lbs.)	Plate Size A	B	C	D	E	F	G
PCUA005	0.5t	4.4	0-5/8	1.7	4.2	8.5	1.2	0.4	2.0
PCUA010	1.0t	9.9	0-3/4	2.5	5.7	11.5	1.9	0.5	2.6
PCUA020	2.0t	16.1	0-1	3.1	6.9	14.5	2.7	0.6	3.0
PCUA030	3.0t	33.0	0-1-1/8	3.3	8.1	16.9	2.9	0.8	4.0
PCUA050	5.0t	47.5	0-2	3.9	9.4	18.9	3.1	0.9	4.3



Before using these products; read and follow instructions in the operator's manual. Never exceed capacity. Do not use for lifting people or loads over people.